

4. DIMENSIONS

MODEL: AB*G30LRTE, AB*G36LRTE

(Unit : mm)

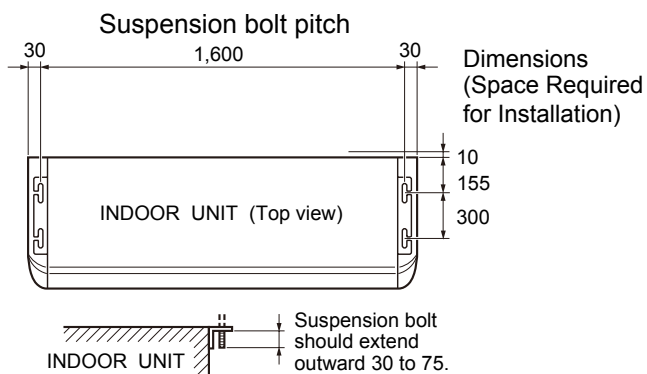
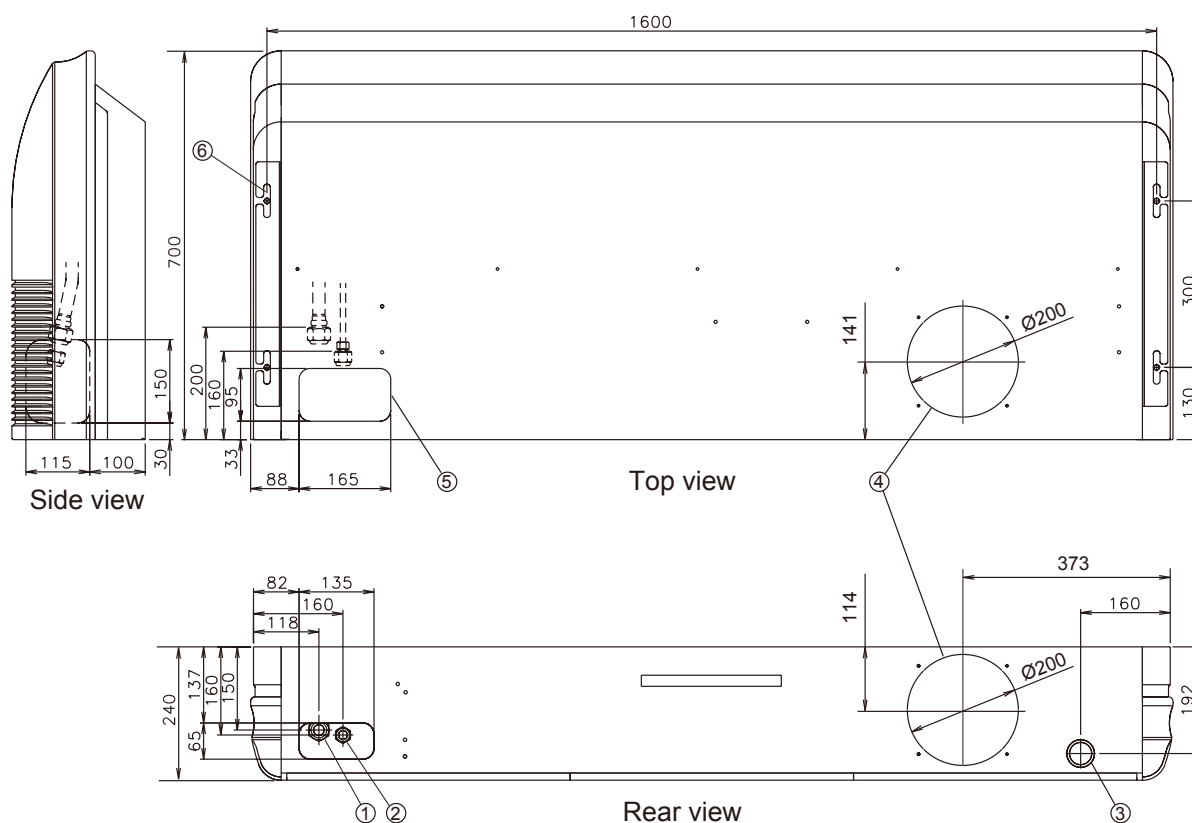

- ① Refrigerant piping flare connection (Gas)
- ② Refrigerant piping flare connection (Liquid)
- ③ Drain piping connection
- ④ Knock out hole for fresh air
- ⑤ Knock out hole for refrigerant piping
- ⑥ Hole for lifting bolt (Use M10 screw bolt)

■ INSTALLATION PLACE

(Unit : mm)

Ceiling

