

**MODELS : AGYE004/ 007/ 009/ 012/ 014GCEH
AGHE004/ 007/ 009/ 012/ 014GCEH**

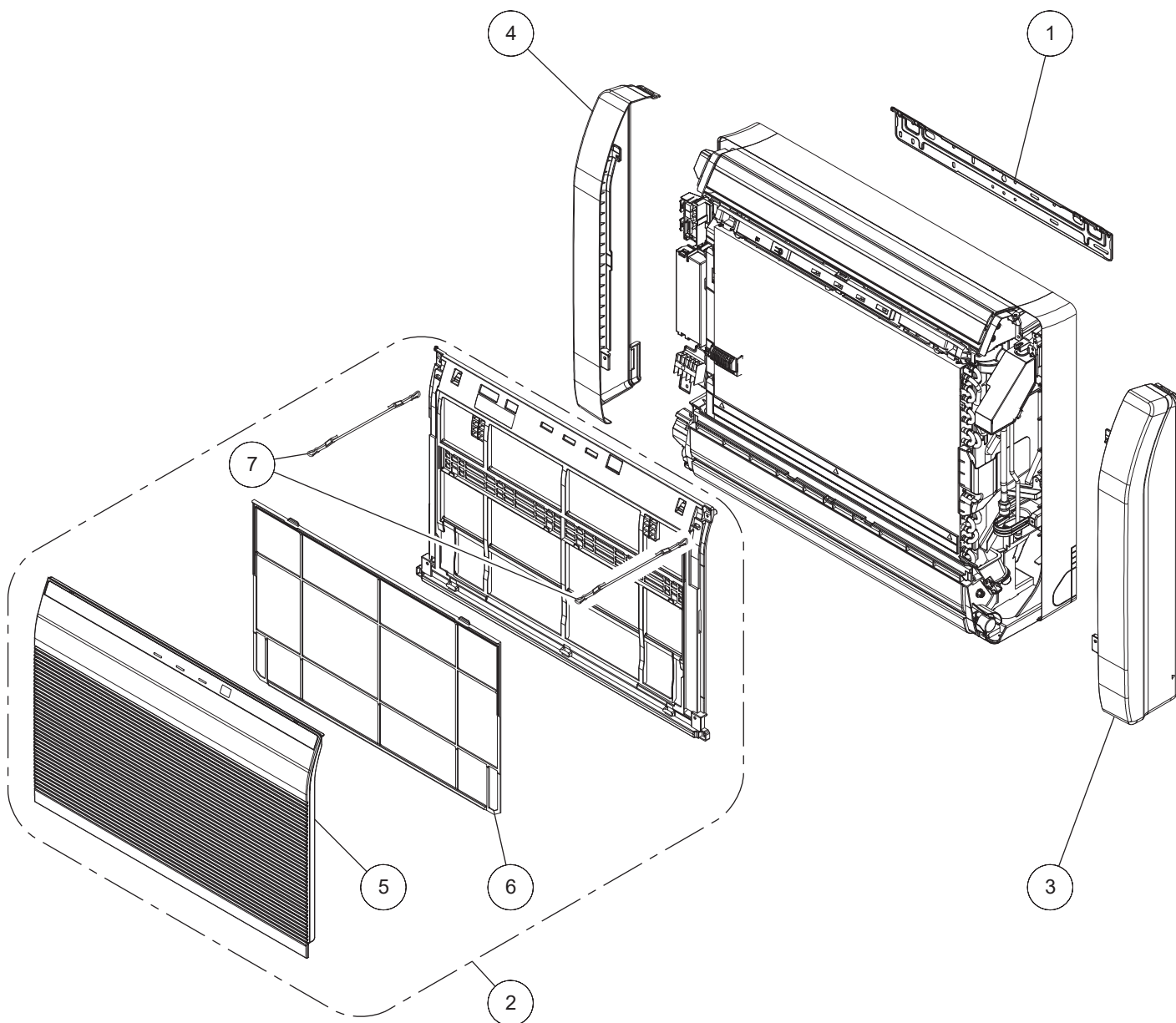

Ref No.	Description	Parts No.					Q'ty
		AG* E004GCEH	AG* E007GCEH	AG* E009GCEH	AG* E012GCEH	AG* E014GCEH	
1	BRACKET PANEL	9316272019	9316272019	9316272019	9316272019	9316272019	
2	FRONT PANEL TOTAL ASSY (FUJITSU)	9316415133	9316415133	9316415133	9316415133	9316415133	
	FRONT PANEL TOTAL ASSY (GENERAL)	9316415140	9316415140	9316415140	9316415140	9316415140	
3	FRONT PANEL R	9316186019	9316186019	9316186019	9316186019	9316186019	
4	FRONT PANEL L	9316187016	9316187016	9316187016	9316187016	9316187016	
5	INTAKE GRILLE ASSY (FUJITSU)	9316418103	9316418103	9316418103	9316418103	9316418103	
	INTAKE GRILLE ASSY (GENERAL)	9316418110	9316418110	9316418110	9316418110	9316418110	
6	AIR FILTER	9316189027	9316189027	9316189027	9316189027	9316189027	
7	ROPE ASSY	9316458017	9316458017	9316458017	9316458017	9316458017	
	AIR CLEAN FILTER ASSY	9316474017	9316474017	9316474017	9316474017	9316474017	

**MODELS : AGYE004/ 007/ 009/ 012/ 014GCEH
AGHE004/ 007/ 009/ 012/ 014GCEH**

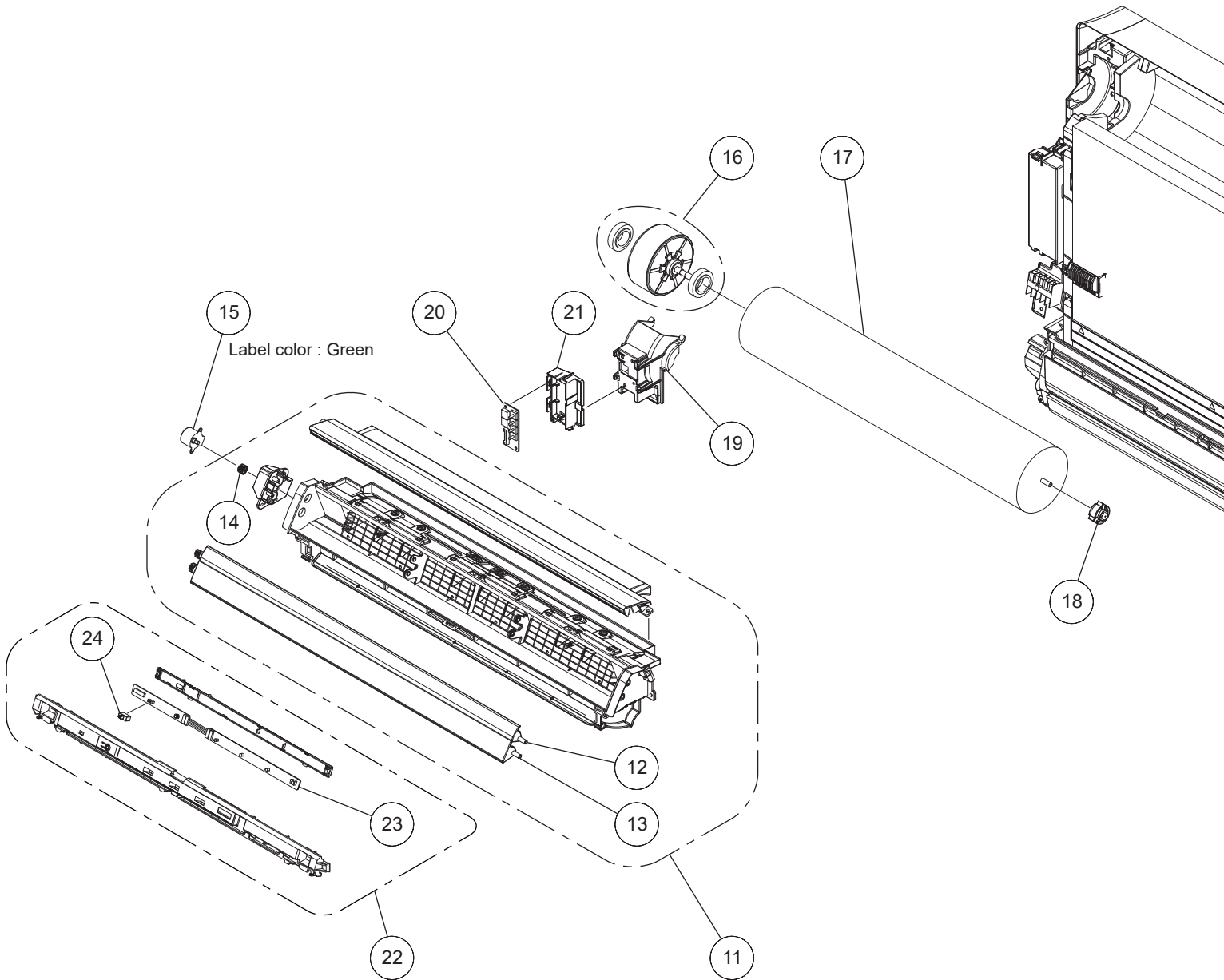

Ref No.	Description	Parts No.					Q'ty
		AG* E004GCEH	AG* E007GCEH	AG* E009GCEH	AG* E012GCEH	AG* E014GCEH	
11	CASING ASSY	9316411012	9316411012	9316411012	9316411012	9316411012	
12	LOUVER U	9316205017	9316205017	9316205017	9316205017	9316205017	
13	LOUVER Z	9316206014	9316206014	9316206014	9316206014	9316206014	
14	GEAR A	9309994003	9309994003	9309994003	9309994003	9309994003	
15	STEP MOTOR	9900384043	9900384043	9900384043	9900384043	9900384043	
16	DC MOTOR	9602850006	9602850006	9602850006	9602850006	9602850006	
17	CROSSFLOW FAN ASSY	9312004034	9312004034	9312004034	9312004034	9312004034	
18	BEARING C ASSY	9306628024	9306628024	9306628024	9306628024	9306628024	
19	MOTOR HOLDER	9316195011	9316195011	9316195011	9316195011	9316195011	
20	SWITCH PCB	9707732030	9707732030	9707732030	9707732030	9707732030	
21	SWITCH BOX	9382488000	9382488000	9382488000	9382488000	9382488000	
22	DISPLAY ASSY	9707570038	9707570038	9707570038	9707570038	9707570038	
23	INDICATOR PCB	9707571059	9707571059	9707571059	9707571059	9707571059	
24	COVER (SLIDE SWITCH)	9316267015	9316267015	9316267015	9316267015	9316267015	

MODELS : AGYE004/ 007/ 009/ 012/ 014GCEH
AGHE004/ 007/ 009/ 012/ 014GCEH

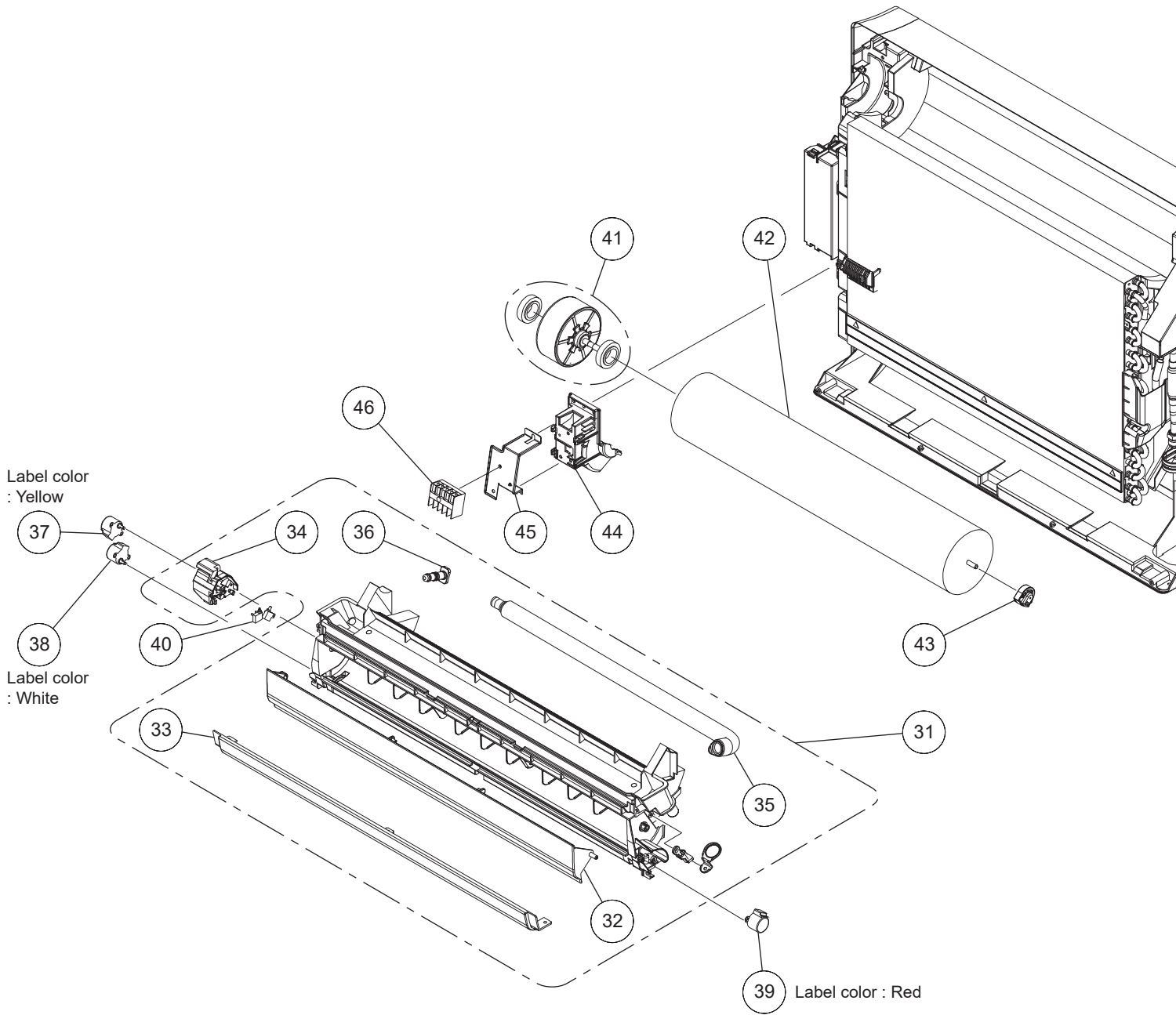

Ref No.	Description	Parts No.					Q'ty
		AG* E004GCEH	AG* E007GCEH	AG* E009GCEH	AG* E012GCEH	AG* E014GCEH	
31	DRAIN PAN ASSY	9316412019	9316412019	9316412019	9316412019	9316412019	
32	DAMPER	9316216013	9316216013	9316216013	9316216013	9316216013	
33	COVER (LOWER)	9316374010	9316374010	9316374010	9316374010	9316374010	
34	COVER (LIMIT SWITCH)	9316217010	9316217010	9316217010	9316217010	9316217010	
35	HOSE (DRAIN) ASSY	9314147029	9314147029	9314147029	9314147029	9314147029	
36	CAP (DRAIN)	9316177017	9316177017	9316177017	9316177017	9316177017	
37	STEP MOTOR	9900384050	9900384050	9900384050	9900384050	9900384050	
38	STEP MOTOR	9900384067	9900384067	9900384067	9900384067	9900384067	
39	STEP MOTOR	9900384074	9900384074	9900384074	9900384074	9900384074	
40	MICROSWITCH	9900424015	9900424015	9900424015	9900424015	9900424015	
41	DC MOTOR	9602851003	9602851003	9602851003	9602851003	9602851003	
42	CROSSFLOW FAN B ASSY	9316309012	9316309012	9316309012	9316309012	9316309012	
43	BEARING C ASSY	9306628024	9306628024	9306628024	9306628024	9306628024	
44	MOTOR HOLDER	9316195011	9316195011	9316195011	9316195011	9316195011	
45	BRACKET (TERMINAL)	9382484002	9382484002	9382484002	9382484002	9382484002	
46	TERMINAL 5P	9900896003	9900896003	9900896003	9900896003	9900896003	

**MODELS : AGYE004/ 007/ 009/ 012/ 014GCEH
AGHE004/ 007/ 009/ 012/ 014GCEH**

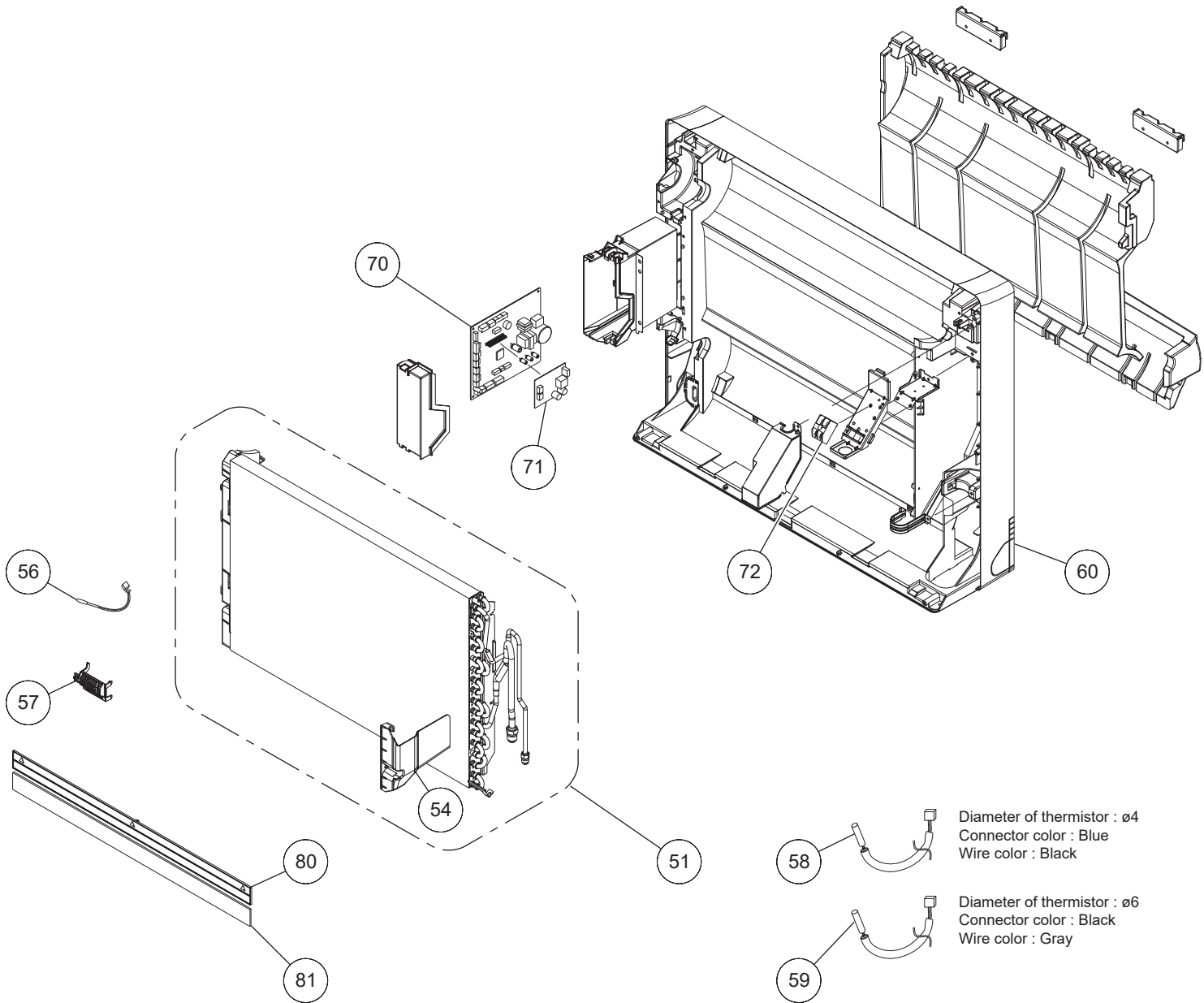

Ref No.	Description	Parts No.					Q'ty
		AG* E004GCEH	AG* E007GCEH	AG* E009GCEH	AG* E012GCEH	AG* E014GCEH	
51	EVAPORATOR TOTAL ASSY	9316091108	9316091061	9316091061	9316091054	9316091054	
54	WATER SEAL	9316271012	9316271012	9316271012	9316271012	9316271012	
56	ROOM THERMISTOR	9900960032	9900960032	9900960032	9900960032	9900960032	
57	ROOM THERMISTOR HOLDER	9316192010	9316192010	9316192010	9316192010	9316192010	
58	PIPE THERMISTOR (INLET)	9900622046	9900622046	9900622046	9900622046	9900622046	
59	PIPE THERMISTOR (OUTLET)	9900623043	9900623043	9900623043	9900623043	9900623043	
60	BASE	9316193017	9316193017	9316193017	9316193017	9316193017	
70	CONTROLLER PCB	9710646034	9710646034	9710646034	9710646034	9710646034	
71	COMMUNICATION PCB	9709373026	9709373026	9709373026	9709373026	9709373026	
72	TERMINAL 2P	9703873027	9703873027	9703873027	9703873027	9703873027	
80	WIND SHIELD PLATE	9382489007	----	----	----	----	
81	INSULATION (SHIELD PLATE)	9382703004	----	----	----	----	