

5. Refrigerant circuit

5-1. Models: AJ*040LCLBH, AJ*045LCLBH, and AJ*054LCLBH

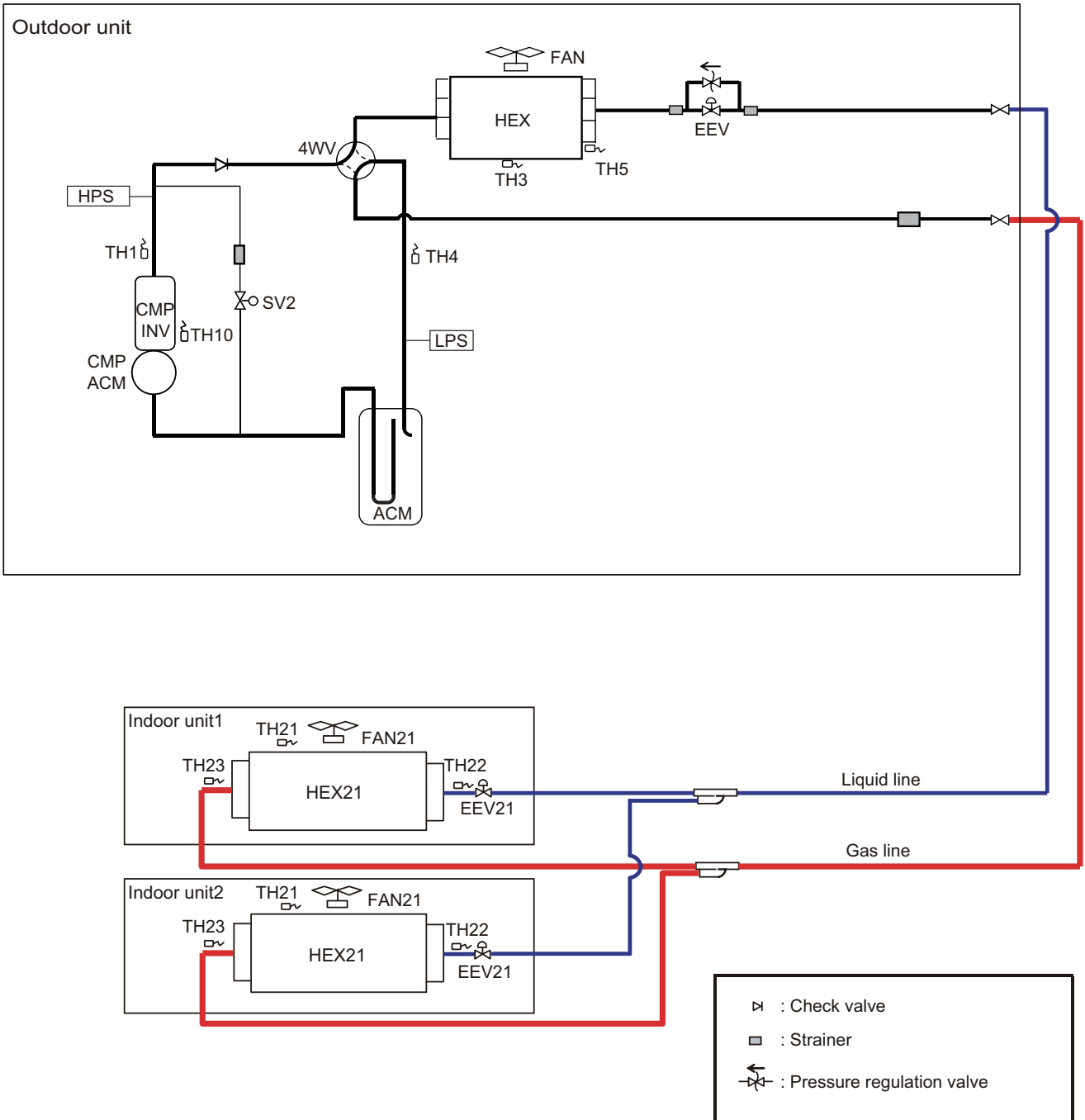

OUTDOOR UNITS

OUTDOOR UNITS

5-2. Symbol description

- Outdoor unit

Symbol	Description	Marking color
CMP	Compressor (Inverter type)	—
HEX	Heat exchanger	—
FAN	Fan	—
ACM	Accumulator	—
HPS	High pressure sensor	—
LPS	Low pressure sensor	—
4WV	4-way valve	—
EEV	Electric expansion valve	—
SV2	Solenoid valve	—
TH1	Discharge temperature thermistor	Blue
TH3	Outdoor temperature thermistor	—
TH4	Suction temperature thermistor	Red
TH5	Heat exchanger (outlet) thermistor	Pink
TH10	Compressor temperature thermistor	—

- Indoor unit

Symbol	Description
HEX21	Heat exchanger
FAN21	Fan
EEV21	Electric expansion valve
TH21	Room temperature thermistor
TH22	Heat exchanger (inlet) thermistor
TH23	Heat exchanger (outlet) thermistor