

6. Wiring diagrams

6-1. Models: AJ*072GALBH, AJ*090GALBH, and AJ*108GALBH

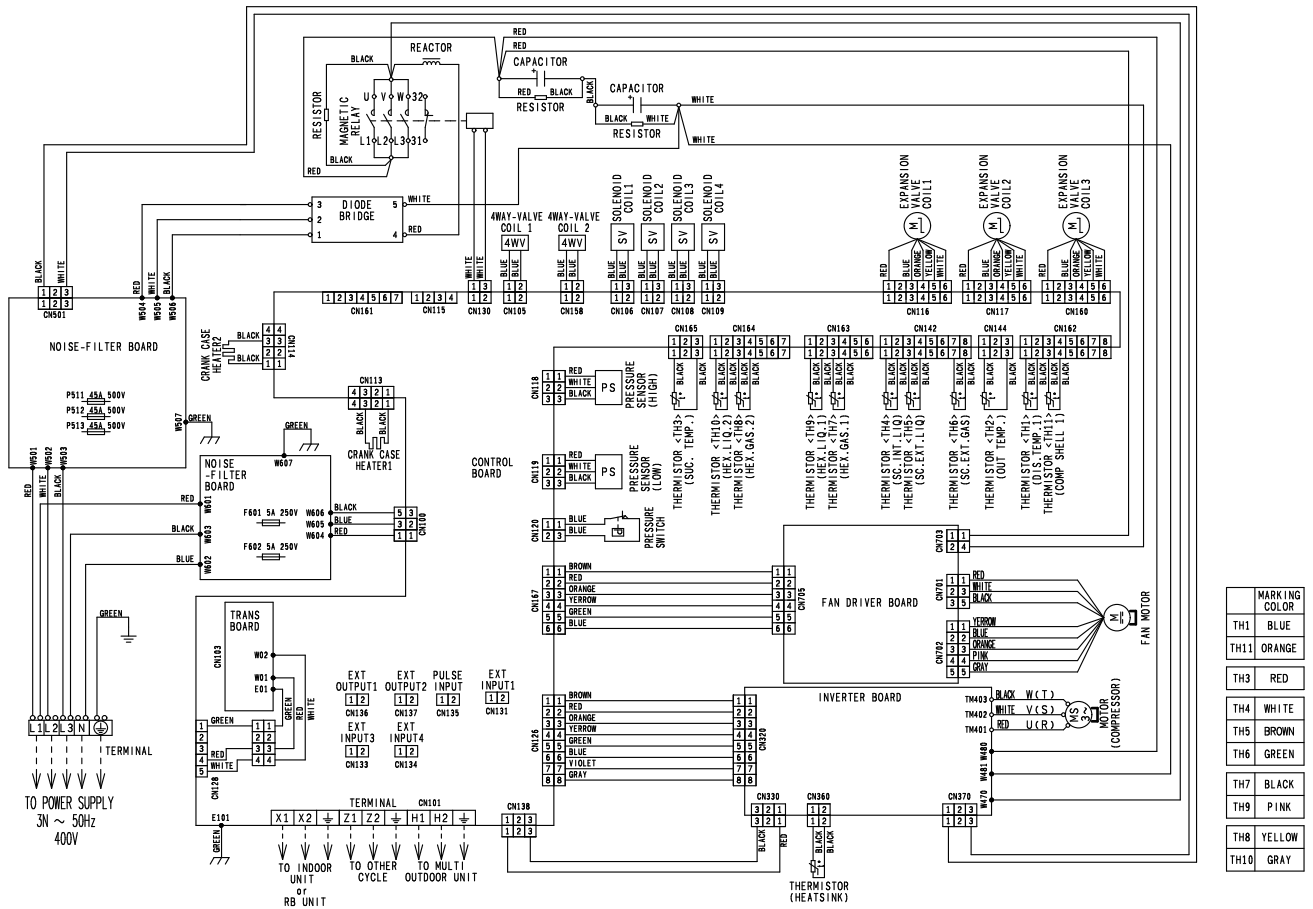

- NOTE:**
- X1 and X2: To be connected to indoor unit or RB unit
 - Z1 and Z2: To be connected to other master outdoor unit
 - H1 and H2: To be connected to outdoor unit within same refrigerant system