

AJ*072LALDH
AJ*090LALDH
AJ*108LALDH
AJ*126LALDH
AJ*144LALDH

INSTALLATION MANUAL

OUTDOOR UNIT

For authorized service personnel only.

English

INSTALLATIONSANLEITUNG

AUßENGERÄT

Nur für autorisiertes Fachpersonal.

Deutsch

MANUEL D'INSTALLATION

UNITÉ EXTÉRIEURE

Pour le personnel agréé uniquement.

Français

MANUAL DE INSTALACIÓN

UNIDAD EXTERIOR

Únicamente para personal de servicio autorizado.

Español

MANUALE DI INSTALLAZIONE

UNITÀ ESTERNA

A uso esclusivo del personale tecnico autorizzato.

Italiano

ΕΓΧΕΙΡΙΔΙΟ ΕΓΚΑΤΑΣΤΑΣΗΣ

ΕΞΩΤΕΡΙΚΉ ΜΟΝΑΔΑ

Μόνο για εξουσιοδοτημένο τεχνικό προσωπικό.

Ελληνικά

MANUAL DE INSTALAÇÃO

UNIDADE EXTERIOR

Apenas para técnicos autorizados.

Português

РУКОВОДСТВО ПО УСТАНОВКЕ

ВНЕШНИЙ МОДУЛЬ

Только для авторизованного обслуживающего персонала.

Русский

MONTAJ KILAVUZU

DIŞ ÜNİTE

Yalnızca yetkili servis personeli için.

Türkçe

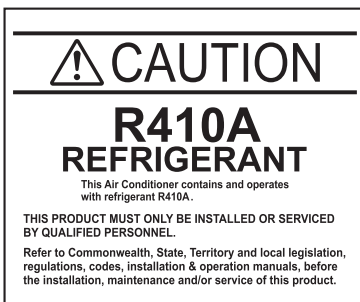

FUJITSU GENERAL LIMITED



PART No. 9378945708-02

INSTALLATION MANUAL

PART No. 9378945708-02
VRF system outdoor unit

[Original instructions]

Contents

1. SAFETY PRECAUTIONS	1
2. ABOUT THIS PRODUCT	2
2.1. Precautions for using R410A refrigerant	2
2.2. Special tools for R410A	2
2.3. Accessories	2
2.4. Combinations	2
2.5. Optional parts	3
3. INSTALLATION WORK	3
3.1. Selecting an installation location	3
3.2. Drain processing	3
3.3. Clearance requirement	3
3.4. Transporting the unit	5
3.5. Installing the unit	5
4. SYSTEM CONFIGURATION	6
4.1. System configuration	6
4.2. Pipe selection	7
4.3. Downsizing of pipe diameter	7
4.4. Protection of pipes	8
5. PIPE INSTALLATION	8
5.1. Brazing	8
5.2. Indoor unit pipe connections	8
5.3. Opening the knockout hole	9
5.4. Pipe connection	9
5.5. Multiple connections	10
6. ELECTRICAL WIRING	11
6.1. The precautions of electrical wiring	11
6.2. Wiring method	12
6.3. Knockout hole	12
6.4. Selecting power supply cable and breaker	12
6.5. Transmission line	13
6.6. Wiring procedure	14
6.7. External input and external output	15
7. FIELD SETTING	16
7.1. Field setting switches	16
7.2. DIP switch setting	16
7.3. Rotary switch setting	16
7.4. Push button setting	16
7.5. Address setting for signal amplifiers	18
7.6. Indoor unit address setting	18
7.7. Resistance measurement of transmission cable (Measure with breaker OFF)	19
8. PIPE INSTALLATION II	19
8.1. Sealing test	19
8.2. Vacuum process	20
8.3. Installing insulation	21
9. TEST RUN	21
9.1. Pre-check for test run	21
9.2. Test run method	21
9.3. Checklist	22
10. LED STATUS	22
10.1. Normal operation codes	22
10.2. Error codes	22
11. INFORMATION	22

1. SAFETY PRECAUTIONS

- Be sure to read this Installation manual thoroughly before installation.
- The warnings and precautions indicated in this Installation manual contain important information pertaining to your safety. Be sure to observe them.
- After installing the unit, perform a test run to make sure the unit operates normally. Then, explain to the customer how to operate and maintain the unit.
- Please pass this Installation manual together with the Operating manual to the customer. Please ask the customer to keep the Operating manual and Installation manual at hand for future reference during the moving or repair of the main unit.

 WARNING	This mark indicates procedures which, if improperly performed, might lead to the death or serious injury of the user.
For installation purposes, be sure to use the parts supplied by the manufacturer or other prescribed parts. Using non-specified parts will cause serious accidents such as falling unit, refrigerant leakage, water leakage, electric shock, and fire.	
To install a unit that uses the R410A refrigerant, use dedicated tools and piping materials that have been manufactured specifically for R410A use. Because the pressure of the R410A refrigerant is approximately 1.6 times higher than the R22, failure to use dedicated piping material or improper installation can cause rupture or injury. It will also cause serious accidents such as refrigerant leakage, water leakage, electric shock, and fire.	
Do not use this equipment with air or any other unspecified refrigerant in the refrigerant lines. Excess pressure can cause a rupture.	
Be sure to install the unit as prescribed, so that it can withstand earthquakes and typhoons or other strong winds. Improper installation can cause the unit to topple or fall, or other accidents.	
Ensure that the outdoor unit is securely installed at a place that can withstand the weight of the unit. Improper installation will cause injuries caused by falling unit.	
If there is a refrigerant leakage, make sure that it does not exceed the concentration limit. If a refrigerant leakage exceeds the concentration limit, it can lead to accidents such as oxygen starvation.	
If a refrigerant leakage occurs during operation, immediately vacate the premises and thoroughly ventilate the area. If the refrigerant is exposed to fire, it will create a hazardous gas.	
Electrical work must be performed in accordance with this Installation manual by a person certified under the national or regional regulations. Be sure to use a dedicated circuit for the unit. An insufficient power supply circuit or improperly performed electrical work can cause serious accidents such as electric shock or fire.	
For wiring, use the prescribed type of cables, connect them securely, making sure that there are no external forces of the cables applied to the terminal connections. Improperly connected or secured cables can cause serious accidents such as overheating the terminals, electric shock, or fire.	
Do not turn ON the power until all work has been completed. Turning ON the power before the work is completed can cause serious accidents such as electric shock or fire.	
After the installation, make sure there is no refrigerant leakage. If the refrigerant leaks into the room and becomes exposed to a source of fire such as a fan heater, stove, or burner, it will create a hazardous gas.	
Use a wall hole pipe. Otherwise, it may cause a short circuit.	
Do not place the outdoor unit near the handrail of the balcony. Children may climb onto the outdoor unit, lean over the handrail and fall over.	
Use only a specified power cable. Poor connection, poor insulation, and exceeding the allowable current will lead to electric shock and fire.	
Attach the connecting cables securely to the terminal. Or secure it firmly with a "wiring suppressor". Loose connection will lead to malfunction, electric shock, and fire.	
Install a breaker to cut off all AC main current at the same time. If you do not install a breaker, it may cause electric shock and fire.	
During installation, make sure that the refrigerant pipe is attached firmly before you run the compressor. Do not operate the compressor under the condition of refrigerant piping not attached properly with 2-way or 3-way valve open. This may cause abnormal pressure in the refrigeration cycle that leads to rupture and even injury.	
During the pump-down operation, make sure that the compressor is turned off before you remove the refrigerant piping. Do not remove the connection pipe while the compressor is in operation with 2-way or 3-way valve open. This may cause abnormal pressure in the refrigeration cycle that leads to breakage and even injury.	
If there is a possibility of touching the fan during maintenance, make sure to turn OFF the power before implementing the maintenance. Even if operations are suspended, the fan of outdoor unit sometimes rotates, so if the fan rotates suddenly while in contact with you may cause serious injury.	

 CAUTION	This mark indicates procedures which, if improperly performed, might possibly result in personal harm to the user, or damage to property.
This unit must be installed by qualified personnel with a capacity certificate for handling refrigerant fluids. Refer to regulation and laws in use on installation place.	
The installation must be carried out in compliance with regulations in force in the place of installation and the installation instructions of the manufacturer.	
This unit is part of a set constituting an air conditioner. It must not be installed alone or with non-authorized by the manufacturer.	
This unit contains no user-serviceable parts. Always consult authorized service personnel to repairs.	
When moving, consult authorized service personnel for disconnection and installation of the unit.	
<ul style="list-style-type: none"> Obtain the distribution network operator's agreement about the power capacity of the power supply system, specification of the cable and the harmonic current, and etc. when you connect the outdoor unit with the power supply. This unit must be connected to a power supply with impedance of 0.33 ohm and below. If the power supply does not satisfy this requirement, please consult the power supplier. This product is intended for professional use. Be sure to use a dedicated power circuit. Never use a power supply shared by another appliance. 	
Do not install the unit in the following areas:	
<ul style="list-style-type: none"> Area with high salt content, such as at the seaside. It will deteriorate metal parts, causing the parts to fall or the unit to leak water. Area filled with mineral oil or containing a large amount of splashed oil or steam, such as a kitchen. It will deteriorate plastic parts, causing the parts to fall or the unit to leak water. Area that generates substances that adversely affect the equipment, such as sulfuric gas, chlorine gas, acid, or alkali. It will cause the copper pipes and brazed joints to corrode, which can cause refrigerant leakage. Area containing equipment that generates electromagnetic interference. It will cause the control system to malfunction, preventing the unit from operating normally. Area that can cause combustible gas to leak, contains suspended carbon fibers or flammable dust, or volatile flammables such as paint thinner or gasoline. If gas leaks and settles around the unit, it can cause a fire. Avoid installing the unit at places where it will come into contact with animals' urine or ammonia. 	
The units are not explosion proof and therefore should not be installed in explosive atmosphere.	
Do not use the unit for special purposes, such as storing food, raising animals, growing plants, or preserving precision devices or art objects. It can degrade the quality of the preserved or stored objects.	
Ground the unit. Do not connect the ground wire to a gas pipe, water pipe, lightning rod, or a telephone ground wire. Improper grounding may cause electric shock.	
Perform draining for the unit according to the Installation manual. Check that the water is properly drained. If the drain processing is improperly installed, water may drip down from the unit, wetting the furniture.	
Do not touch the fins with bare hands.	
Be sure not to start or stop the operation of air conditioning with power breaker. Otherwise, it may cause malfunction or water leakage.	
When setting it up near the equipment that generates electromagnetic waves and the equipment that generates the higher harmonics wave, be sure to take measures against noise. Otherwise, it may cause malfunction or failure.	
When energizing to the crankcase heater, please turn on the power 12 hours or earlier before operation begins. When the energizing time is short, it may cause failure. Besides, please do not turn off power during the busy season.	
Children should be monitored to ensure they do not play with the device.	
This product is not intended to be used by people (including children) with physical, sensory or mental disability, or persons lacking experience or knowledge unless they have been given by the through a person responsible for their safety, supervision or instruction concerning the use of the device.	

2. ABOUT THIS PRODUCT

2.1. Precautions for using R410A refrigerant







Pay careful attention to the following points:
Since the working pressure is 1.6 times higher than that of R22 models, some of the piping and installation and service tools are special. (See the table in the SPECIAL TOOLS FOR R410A section.) Especially, when replacing a conventional refrigerant (other than R410A) model with a new refrigerant R410A model, always replace the conventional piping and flare nuts with the R410A piping and flare nuts.
Models that use refrigerant R410A have a different charging port thread diameter to prevent erroneous charging with R22, R407C and for safety. Therefore, check beforehand. [The charging port thread diameter for R410A is 1/2 UNF 20 threads per inch.]
Be more careful than the installation of the refrigerant (other than R410A) models, not to enter foreign matters (oil, water, etc.) and other refrigerant into the piping. Also, when storing the piping, securely seal the openings by pinching, taping, etc.
When charging the refrigerant, take into account the slight change in the composition of the gas and liquid phases, and always charge from the liquid phase side whose composition is stable.

2.2. Special tools for R410A

Tool name	Contents of change for R22 tool
Gauge manifold	Pressure is huge and cannot be measured with a conventional gauge. To prevent erroneous mixing of other refrigerants, the diameter of each port has been changed. It is recommended to use a gauge manifold with a high pressure display range -0.1 to 5.3 MPa and a low pressure display range -0.1 to 3.8 MPa.
Charging hose	To increase pressure resistance, the hose material and base size were changed.
Vacuum pump	A conventional vacuum pump can be used by installing a vacuum pump adapter. <ul style="list-style-type: none"> A conventional vacuum pump can be used by installing a vacuum pump adapter. Be sure that the pump oil does not back flow into the system. Use one capable for vacuum suction of -100.7kPa (5 Ton, -755mmHg).
Gas leakage detector	Special gas leakage detector for HFC refrigerant R410A.

2.3. Accessories

Use connecting parts as required.
Do not throw away the connecting parts until the installation has been complete.

Name and shape	Q'ty	Application
Specifications manual 	1	—
Installation manual 	1	(This manual)
Joint pipe A 	1	For connecting gas pipe (Straight type)
Joint pipe B 	1	For connecting gas pipe (L type)
Cable tie 	4	For binding power cable and transmission cable
Grommet edging 	2	For power supply cable and connection cable installation. Attach to the knockout hole.

2.4. Combinations

A maximum of 3 outdoor units can be connected to 1 refrigerant system. The combination of outdoor units per refrigerant system and the number of indoor units that can be connected are as follows:

Model	Nominal System Capacity [HP]	Connectable total indoor unit capacity ratio [%]
AJ*072LALDH	8	50 to 150 (*1)
AJ*090LALDH	10	
AJ*108LALDH	12	
AJ*126LALDH	14	
AJ*144LALDH	16	

*1: The conditions may differ depending on the connected indoor unit. For more information, please refer to the Design & Technical manual.

Space saving combination

Combination (HP)	8	10	12	14	16	18	20	22	24	26	28	30
Outdoor Unit 1 (HP)	8	10	12	14	16	10	10	14	14	16	16	16
Outdoor Unit 2 (HP)	—	—	—	—	—	8	10	8	10	10	12	14
Outdoor Unit 3 (HP)	—	—	—	—	—	—	—	—	—	—	—	—
Maximum Connectable Indoor Unit	17	21	26	30	34	39	43	47	52	56	60	64

Combination (HP)	32	34	36	38	40	42	44	46	48
Outdoor Unit 1 (HP)	16	16	16	16	16	16	16	16	16
Outdoor Unit 2 (HP)	16	10	10	12	14	16	16	16	16
Outdoor Unit 3 (HP)	—	8	10	10	10	10	12	14	16
Maximum Connectable Indoor Unit	64	64	64	64	64	64	64	64	64

When connecting outdoor units, install the outdoor unit with the largest nominal system capacity nearest to the refrigerant pipe and indoor unit, followed by those with lesser nominal system capacities. (Outdoor unit 1 ≥ Outdoor unit 2 ≥ Outdoor unit 3)

Energy-saving combination

Combination (HP)	8	10	12	14	16	18	20	22	24	26	28	30
Outdoor Unit 1 (HP)	—	—	—	—	8	—	12	—	8	10	12	14
Outdoor Unit 2 (HP)	—	—	—	—	8	—	8	—	8	8	8	8
Outdoor Unit 3 (HP)	—	—	—	—	—	—	—	—	8	8	8	8
Maximum Connectable Indoor Unit	*	*	*	*	34	*	43	*	52	56	60	64

Combination (HP)	32	34	36	38	40	42	44	46	48
Outdoor Unit 1 (HP)	12	14	12	14	14	14	16	—	—
Outdoor Unit 2 (HP)	12	12	12	12	14	14	14	—	—
Outdoor Unit 3 (HP)	8	8	12	12	12	14	14	—	—
Maximum Connectable Indoor Unit	64	64	64	64	64	64	64	*	*

* Means that the energy-saving combination is unavailable.

When connecting outdoor units, install the outdoor unit with the largest nominal system capacity nearest to the refrigerant pipe and indoor unit, followed by those with lesser nominal system capacities. (Outdoor unit 1 ≥ Outdoor unit 2 ≥ Outdoor unit 3)

2.5. Optional parts

CAUTION

The following parts are optional parts specific to R410A refrigerant. Do not use parts other than those listed below.

2.5.1 Outdoor unit branch kit

Model	Total cooling capacity of indoor unit [kW]
UTP-DX567A	ALL

2.5.2 Separation tube

Model		Total cooling capacity of indoor unit [kW]
for 2 pipes	for 3 pipes	
UTP-AX054A	—	19.6 or less
UTP-AX090A	UTP-BX090A	28.0 or less
UTP-AX180A	UTP-BX180A	28.1 to 56.0
UTP-AX567A	UTP-BX567A	56.1 or more

2.5.3 Header

3-6 branches	3-8 branches	Total cooling capacity of indoor unit [kW]
UTR-H0906L	UTR-H0908L	28.0 or less
UTR-H1806L	UTR-H1808L	28.1 to 56.0

2.5.4 External connect kit

Model	Usage
UTY-XWZXZ6	For External input (CN131, CN133, CN134)
	For External output (Error status / CN136) (Operation status / CN137)
UTY-XWZXZF	For External input (CN135)
UTY-XWZXZ9	For External output (Base heater / CN115)

3. INSTALLATION WORK

Please obtain the approval of the customer when selecting the location of installation and installing the main unit.

3.1. Selecting an installation location

WARNING

Install the unit in a location that can withstand its weight, and where it will not topple or fall.

Calculate the proper refrigerant concentration if you will be installing it in an enclosed location.

$$\frac{\text{Total amount of replenished refrigerant in refrigerant facility (kg)}}{\text{Capacity of smallest room where unit is installed (m}^3\text{)}} \leq \text{Refrigerant concentration (kg/m}^3\text{)} (0.42 \text{ kg/m}^3)$$

If the results of the calculation exceed the concentration limit, increase the room surface area or install a ventilation duct.

CAUTION

Select an installation location by observing the following precautions:

Install the unit level. (Within 3 degrees)

Install this unit in a location with good ventilation.

If the unit must be installed in an area within easy reach of the general public, install as necessary a protective fence or the like to prevent their access.

Install the unit in an area that would not inconvenience your neighbors, as they could be affected by the airflow coming out from the outlet, noise, or vibration. If it must be installed in proximity to your neighbors, be sure to obtain their approval.

If the unit is installed in a cold region that is affected by snow accumulation, snow fall, or freezing, take appropriate measures to protect it from those elements. To ensure a stable operation, install inlet and outlet ducts.

Install the unit in an area that would not cause problems even if the drain water is discharged from the unit. Otherwise, provide drainage that would not affect people or objects.

Install the unit in an area that has no heat sources, vapors, or the risk of the leakage of flammable gas in the vicinity.

Install the unit in an area that is away from the exhaust or vent ports that discharge vapor, soot, dust, or debris.

Install the indoor unit, outdoor unit, power supply cable, transmission cable and remote control cable at least 1 meter away from a television or radio. The purpose of this is to prevent TV reception interference or radio noise. (Even if they are installed more than 1 meter apart, you could still receive noise under some signal conditions.)

Keep the length of the piping of the indoor and outdoor units within the allowable range.

For maintenance purposes, do not bury the piping.

3.2. Drain processing

- The drain water is discharged from the bottom of the equipment. Construct a drain ditch around the base and discharge the drain water properly.
- When installing on a roof, perform floor waterproofing properly.

Drain processing:

- The drain water from the base of the outdoor unit may generate during operations. Perform drain processing, as necessary.
- When you want to prevent the drain water from leaking at the perimeter, construct a ditch for the drain water as shown in the figure.
- Provide a central drain pan, as necessary.

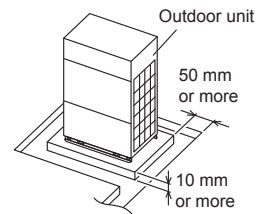

3.3. Clearance requirement

CAUTION

When installing the outdoor unit, pay attention to the following items.

Provide sufficient installation space, such as transportation route, maintenance space, ventilation space, refrigerant piping space, and passageways.

Pay attention to the specifications of the installation space as shown in the figure. If the unit is not installed according to specifications, it may cause short circuit or poor performance. The unit may be prone to lapse into non-operation due to high pressure protection.

Do not place obstructions in the air flow outlet direction. If there is an obstruction in the outlet direction, install an outlet duct.

When there is a wall in front of the unit, provide a space of 500 mm or more as maintenance space.

When there is a wall at the left side of the unit, provide a space of 30 mm or more as maintenance space.

An outdoor temperature of 35 degrees in air-conditioned operation is assumed for the installation space in this item. If the outdoor temperature exceeds 35 degrees and the outdoor unit is operating at a load exceeding its rated ability, provide a larger inlet space.

If you are installing more outdoor units than indicated here, please ensure sufficient space or consult your distributing agent as it may affect the performance due to short circuit and other problems.

3.3.1 When install nearby limited height wall

- (1) Single and multiple installations
- There are no restrictions on the height of the side wall.
- Provide installation spaces L1 and L2 in accordance with the table below according to the wall height (front side, rear side) conditions.
- Provide installation spaces other than L1 and L2 in accordance with the conditions shown in the figure below.
- Ventilation resistance can be ignorable when the distance from a wall or product, etc. is larger than 2 m.

Wall height condition [mm]	Necessary installation space [mm]
When H1 is 1,500 or less	$L1 \geq 500$
When H1 is 1,500 or more	$L1 \geq 500 + h1 + 2$
When H2 is 500 or less	$L2 \geq 100$
When H2 is 500 or more	$L2 \geq 100 + h2 + 2$

Single installation

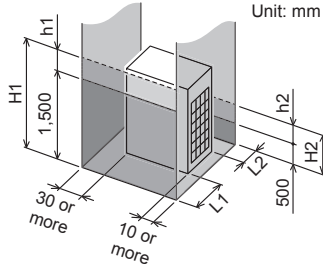

Multiple installations

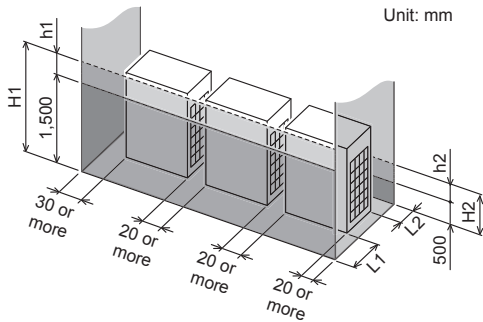

- (2) Concentrated installation
- Provide installation spaces L3, L4, and L5 in accordance with the table below according to the wall height (front side, rear side) conditions.
- Provide installation spaces other than L3, L4, and L5 in accordance with the conditions shown in the figure below.
- Ventilation resistance can be ignorable when the distance from a wall or product, etc. is larger than 2 m.

Wall height condition [mm]	Necessary installation space [mm]
When H3 is 1500 or less	$L3 \geq 500$
When H3 is 1500 or more	$L3 \geq 500 + h3 + 2$
When H4 is 500 or less	$L4 \geq 200$
When H4 is 500 or more	$L4 \geq 200 + h4 + 2$
When H5 is 500 or less	$L5 \geq 200$
When H5 is 500 or more	$L5 \geq 200 + h5 + 2$

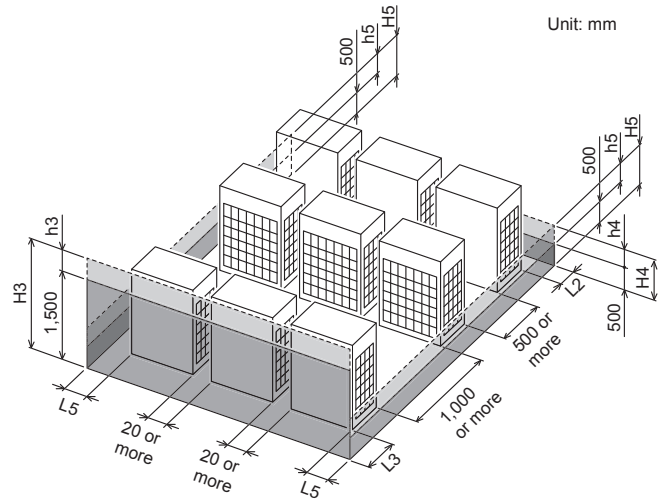
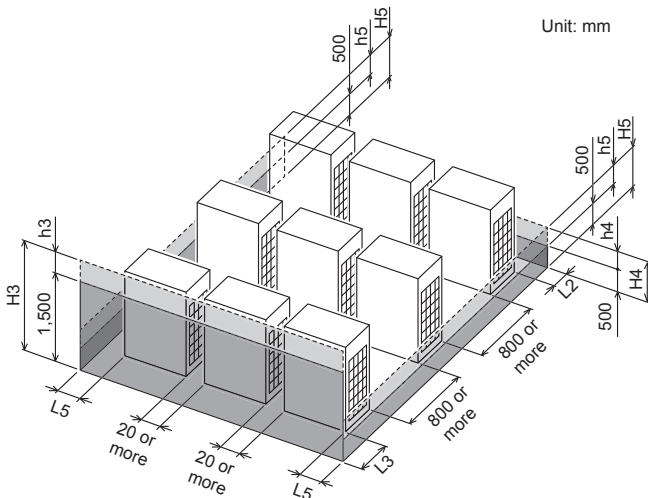

3.3.2 When install near unlimited height wall

- (1) Single and multiple installations
- There are no restrictions on the height of the wall.
- The wall (without height restrictions) must not exist on the both sides (left / right) of outdoor unit. Also, must not exist on the both sides (front / rear) of outdoor unit.
- Provide installation spaces other than L6 in accordance with the conditions shown in the figure below.
- Ventilation resistance can be ignorable when the distance from a wall or product, etc. is larger than 2 m.

When installing with the rear of the outdoor unit facing the wall side

Condition	Necessary installation space
When $B \geq 400$ (mm)	$L6 \geq 200$ (mm)
When $20 \leq B < 400$ (mm)	$L6 \geq 200 + (400 - B) \times 3$ (mm)

Single installation

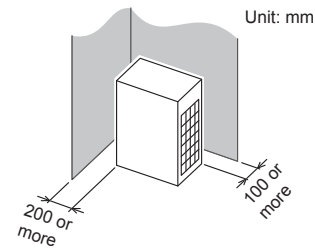

Multiple installations

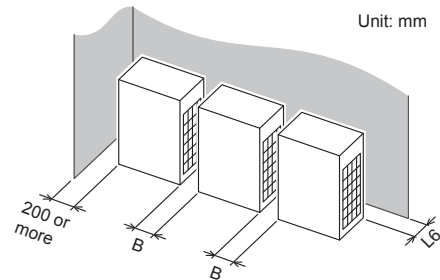

Example :
When B is made 200 mm
 $L6 \geq 200 + (400 - 200) \times 3 = 800$ mm

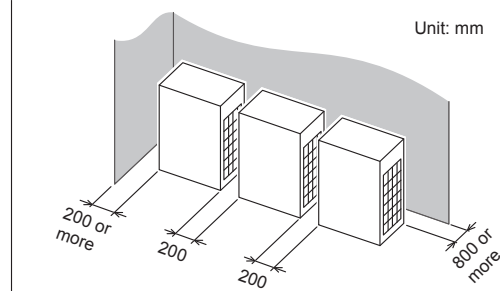

When installing with the FRONT of the outdoor unit facing the wall side

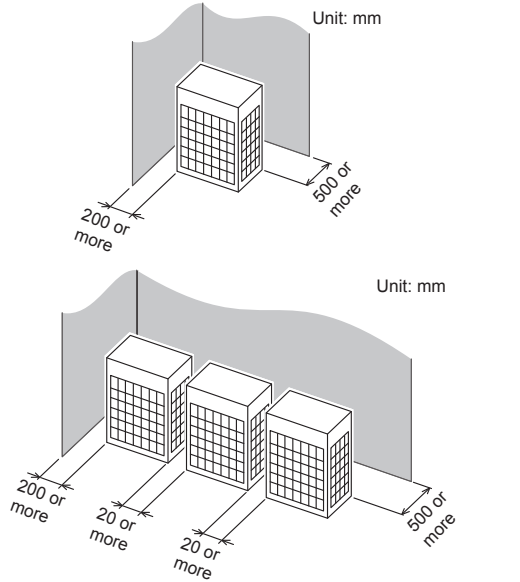

(2) Concentrated Installation

- The wall (without height restrictions) must not exist on the both sides (left / right) of outdoor unit. Also, must not exist on the both sides (front / rear) of outdoor unit.
- Ventilation resistance can be ignorable when the distance from a wall or product, etc. is larger than 2 m.

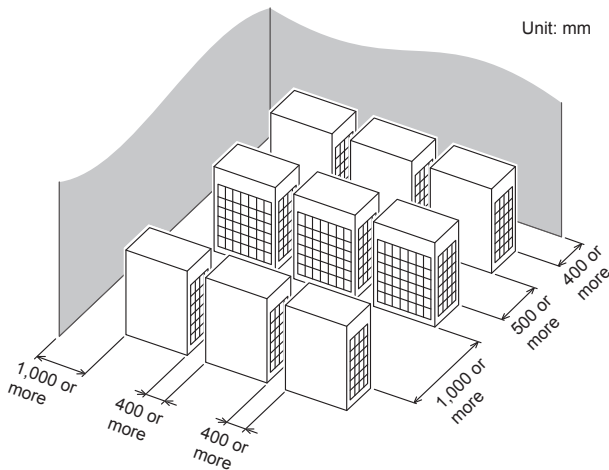
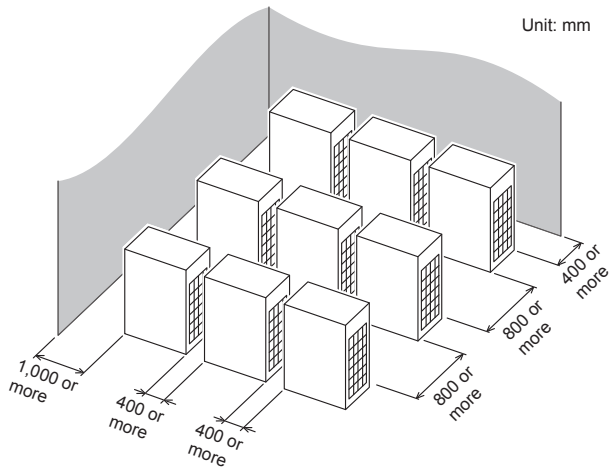

3.3.3 When there are obstacles above the product

When there are obstacles above the product, keep the minimum installation height as shown in the figure and install the outlet duct.

When installing the outlet duct, you must set the high static pressure mode with the push-button switch. (Similar when installing anti-snow hood)

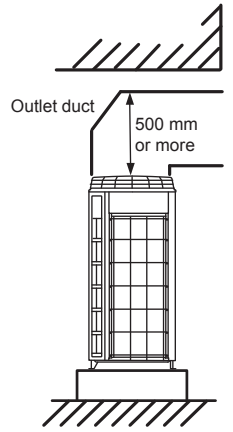

Setting high static pressure mode

Follow the instructions in the table below to set the high static pressure mode.

Condition	High static pressure mode setting (*2)
Static Pressure (SP): 0 ≤ SP ≤ 30 (Pa) (*1)	Set to High static pressure 1
Static Pressure (SP): 30 < SP ≤ 82 (Pa) (*1)	Set to High static pressure 2

*1: Static pressure is the airflow resistance that includes the discharge duct resistance & the other additional resistance like discharge grill and so on.

*2: Refer to the section on Push button setting in "7. FIELD SETTING".

3.4. Transporting the unit

Hoisting method

- When hanging the outdoor unit and conveying it to installation location, hang the unit with rope by passing through the 4 opening holes on bottom of front and rear side as shown in figure.
- Use 2 ropes at least 8 m long. If used shorter length, it may cause to damage to the unit.
- Use the sufficiently strong rope to bear the unit's weight.
- Place the protective board or filler cloth at the place where the cabinet may come into contact with rope to prevent from damages. Without using them, cabinet may cause to damage or deform.
- During the hanging unit, make sure to keep the unit level to prevent from falling.
- To prevent the unit swing accident or falling down of the unit, do not apply any impact to the unit when it is hanging.

Product mass (kg)	
AJ*072LALDH	252
AJ*090LALDH	252
AJ*108LALDH	275
AJ*126LALDH	275
AJ*144LALDH	275

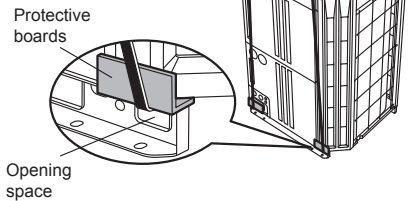

Lifting by forklift

- When using the forklift to lift the unit, pass the forklift arms through the opening space as shown in below.
- **Front:** Bottom of the wooden delivery pallet.
- **Side:** Space between pallet and cabinet. (Enable to remove the pallet from cabinet.)
- Be careful not to be damaged.

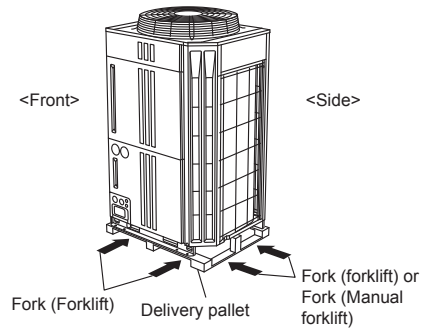

Lifting by forklift (Manual forklift: hand-fork)

- When using the manual forklift to lift the unit, pass the forklift arms through to the opening space between pallet and cabinet from side.

3.5. Installing the unit

- Install the unit level. (within 3 degrees).
- Install 4 or more anchor bolts at the 8 locations indicated by arrows (Fig. A).
- Place the left and right anchor bolts at a distance further away than the dimensions of A in the Table A. (Excluding the case where anchor bolts are installed at 8 places.)

Fig. A

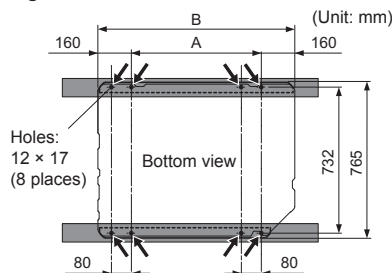
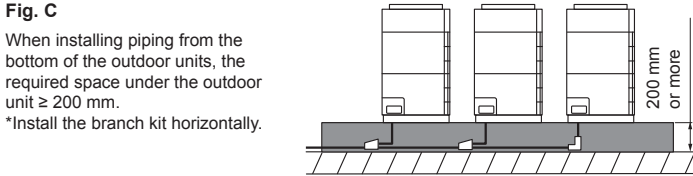
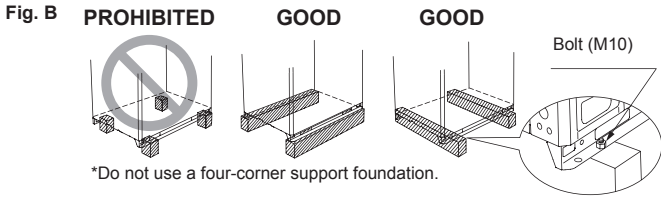

Table. A

Model	A	B
AJ*072LALDH	610	930
AJ*090LALDH	610	930
AJ*108LALDH	920	1240
AJ*126LALDH	920	1240
AJ*144LALDH	920	1240

- To minimize vibration, do not install the outdoor unit directly on the ground. Instead, install it on top of a firm platform (such as concrete block). (Fig. B)
- The foundation base should be able to support the product and the foot width of the product should be more than 46.5 mm.
- Depending on the installation condition, vibration during the operation of the unit may cause noise and vibration. Install vibration-proofing materials (such as rubber pads).
- Consider the removal space of the connection piping when installing the foundation.
- Secure the equipment firmly with anchor bolts, washers, and nuts.



4. SYSTEM CONFIGURATION

For detailed information, refer to the Design and Technical Manual.

4.1. System configuration

CAUTION

- When connecting multiple outdoor units, set the nearest outdoor unit to the indoor unit on the refrigerant pipe as the primary unit.
- When connecting multiple outdoor units, install the outdoor unit with the largest nominal system capacity nearest to the indoor unit on the refrigerant pipe, followed by those with less nominal system capacities.

[Capacity: Primary \geq Subordinate]

- Always keep to the limit on the total amount of refrigerant. Exceeding the limit on the total amount of refrigerant when charging will lead to malfunction.

4.1.1 In case of 1 outdoor unit connected

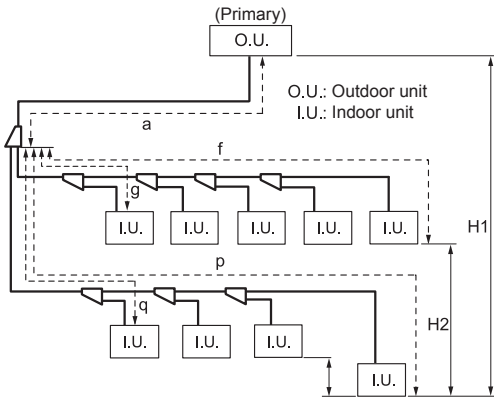

Allowable pipe length (actual pipe length)

Between primary outdoor unit and the farthest indoor unit	165 m or less	a + f a + p
Between the first separation tube and the farthest indoor unit	90 m or less	f, p
(Farthest indoor unit) - (Closest indoor unit)	60 m or less	f(p) - g(q)
Total pipe length	700 m or less	Total

Allowable height difference

Between outdoor unit and indoor unit (When indoor unit is installed below)	50 m or less	H1
Between outdoor unit and indoor unit (When outdoor unit is installed below)	40 m or less	
Between indoor units	15 m or less	H2, H3

- Total refrigerant amount: 31.5 kg or less

4.1.2 In case of 2 outdoor units connected

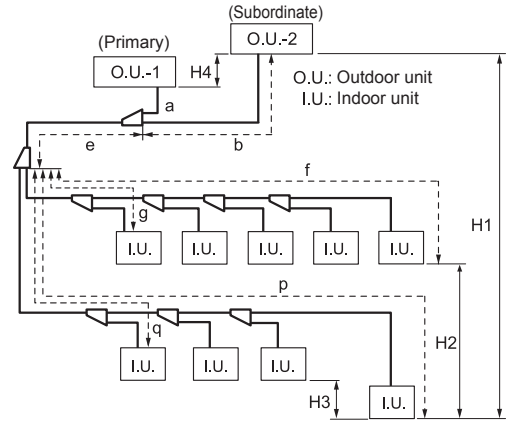

Allowable pip length (actual pipe length)

Between primary outdoor unit and the farthest indoor unit	165 m or less	a + e + f a + e + p
Between the first separation tube and the farthest indoor unit	90 m or less	f, p
(Farthest indoor unit) - (Closest indoor unit)	60 m or less	f(p) - g(q)
Total pipe length	1000 m or less	Total
Between outdoor unit and outdoor unit branch kit	3 m or less	a, b

Allowable height difference

Between outdoor unit and indoor unit (When indoor unit is installed below)	50 m or less	H1
Between outdoor unit and indoor unit (When outdoor unit is installed below)	40 m or less	
Between indoor units	15 m or less	H2, H3
Between outdoor units	0.5 m or less	H4

- Total refrigerant amount: 63 kg or less
- Outdoor unit capacity: Primary \geq Subordinate

4.1.3 In the case of 3 outdoor units connected

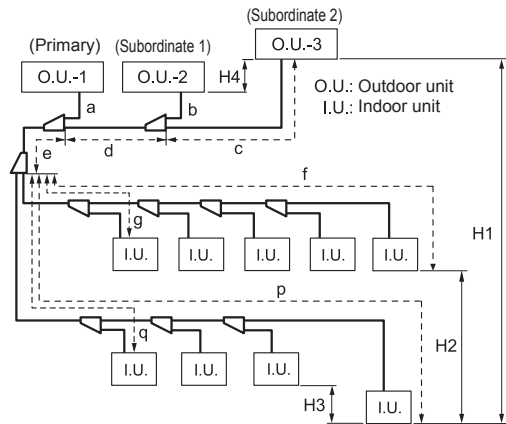

Allowable pip length (actual pipe length)

Between primary outdoor unit and the farthest indoor unit	165 m or less	a + e + f a + e + p
Between the first separation tube and the farthest indoor unit	90 m or less	f, p
(Farthest indoor unit) - (Closest indoor unit)	60 m or less	f(p) - g(q)
Total pipe length	1000 m or less	Total
Between outdoor unit and outdoor unit branch kit	3 m or less	a, b, c
Between the farthest outdoor unit and the first outdoor unit branch kit	12 m or less	b + d c + d

Allowable height difference

Between outdoor unit and indoor unit (When indoor unit is installed below)	50 m or less	H1
Between outdoor unit and indoor unit (When outdoor unit is installed below)	40 m or less	
Between indoor units	15 m or less	H2, H3
Between outdoor units	0.5 m or less	H4

- Total refrigerant amount: 94.5 kg or less
- Outdoor unit capacity: Primary \geq Subordinate 1 \geq Subordinate 2

NOTES:

- If the outdoor temperature during cooling operation is expected to be -5 °C or less, outdoor unit must be installed lower than 5 m or less from the indoor unit.
- Please refer to "8.3.2. Checking total amount of refrigerant and calculating the amount of refrigerant charge to be added" for the total amount of refrigerant.

4.2. Pipe selection

CAUTION

This unit is designed specifically for use with the R410A refrigerant. Pipes for R407C or R22 may not be used with this unit. Do not use existing pipes. Improper pipe selection will degrade performance.

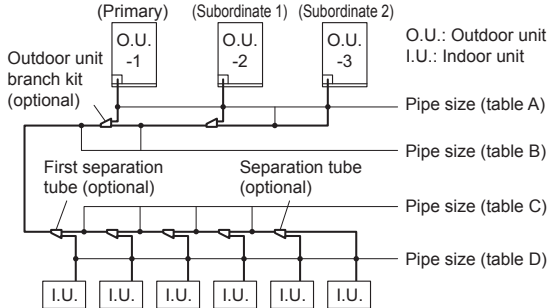

(Wall thickness and pipe material for each diameter)

Outside Diameter	mm	6.35	9.52	12.70	15.88	19.05	22.22	28.58	34.92	41.27	
Wall Thickness (*3)	mm	0.8	0.8	0.8	1.0	1.2	1.0	1.0	1.2	1.43	
Material		COPPER (*1) JIS H3300 C1220T-O or equivalent					COPPER (*2) JIS H3300 C1220T-H or equivalent				

*1: Allowable tensile stress ≥ 33 (N/mm²)

*2: Allowable tensile stress ≥ 61 (N/mm²)

*3: Endurance pressure of the pipes 4.2 MPa

Select the pipe size in accordance with local rules.

Table. A (Between outdoor unit and outdoor unit branch kit)

HP	Outdoor unit cooling capacity (kW)	Outside diameter mm (in)		Branch kit (*4)
		Liquid pipe	Gas pipe	
8	22.4	12.70 (1/2")	22.22 (7/8")	UTP-CX567A
10	28.0	12.70 (1/2")	22.22 (7/8")	
12	33.5	12.70 (1/2")	28.58 (1-1/8")	
14	40.0	12.70 (1/2")	28.58 (1-1/8")	
16	45.0	12.70 (1/2")	28.58 (1-1/8")	

*4: For the installation method, refer to "5.4. Multiple connections".

Table. B (Between outdoor unit branch kits or outdoor unit branch kit and first separation tube)

Total cooling capacity of outdoor unit (kW)	Outside diameter (mm)	
	Liquid pipe	Gas pipe
22.4 to 28.0	12.70 (1/2")	22.22 (7/8")
28.1 to 45.0	12.70 (1/2")	28.58 (1-1/8")
45.1 to 56.0	15.88 (5/8")	28.58 (1-1/8")
56.1 to 80.0	15.88 (5/8")	34.92 (1-3/8")
80.1 to 96.0	19.05 (3/4")	34.92 (1-3/8")
96.1 or more	19.05 (3/4")	41.27 (1-5/8")

Table. C (Between separation tubes)

Total cooling capacity of indoor unit (kW)	Outside diameter (mm)	
	Liquid pipe	Gas pipe
2.2 to 11.1	9.52 (3/8")	15.88 (5/8")
11.2 to 13.9	9.52 (3/8")	19.05 (3/4")
14.0 to 19.6	12.70 (1/2")	19.05 (3/4")
19.7 to 28.0	12.70 (1/2")	22.22 (7/8")
28.1 to 44.7	12.70 (1/2")	28.58 (1-1/8")
44.8 to 56.0	15.88 (5/8")	28.58 (1-1/8")
56.1 to 80.0	15.88 (5/8")	34.92 (1-3/8")
80.1 to 95.0	19.05 (3/4")	34.92 (1-3/8")
95.1 or more	19.05 (3/4")	41.27 (1-5/8")

* If the selected pipe diameter between separation tubes (based on table "C1") becomes larger than the pipe diameter between outdoor unit branch kit and the first separation tube (based on table "B1"), please select the pipe whose diameter is equal to the one between outdoor unit branch kit and the first separation tube.

(If pipe diameter C1 > B1, select pipe size from table B1)

* Total cooling capacity of indoor unit" is the total value for the cooling capacity of indoor unit connected downstream.

Table. D (Between separation tube to indoor unit)

Model code	Cooling capacity of indoor unit (kW)	Outside diameter mm (in)	
		Liquid pipe	Gas pipe
04, 07, 09, 12, 14	1.1, 2.2, 2.8, 3.6, 4.5	6.35 (1/4")	12.70 (1/2")
18, 24, 30, 34	5.6, 7.1, 9.0, 10.0	9.52 (3/8")	15.88 (5/8")
36, 45, 54, 60	11.2, 12.5, 14.0, 18.0	9.52 (3/8")	19.05 (3/4")
72, 90, 96	22.4, 25.0, 28.0	12.70 (1/2")	22.22 (7/8")

Use a standard separation tube for pipe branching. Do not use a T tube as it does not separate the refrigerant evenly.

Table. E (Separation tube / Header)

Total cooling capacity of indoor unit (kW)	Separation tube (*5)	Total cooling capacity of indoor unit (kW)	Header (*5)	
			3-6 Branches	3-8 Branches
19.6 or less	UTP-AX054A	28.0 or less	UTR-H0906L	UTR-H0908L
28.0 or less	UTP-AX090A	28.1 to 56.0	UTR-H1806L	UTR-H1808L
28.1 to 56.0	UTP-AX180A			
56.1 or more	UTP-AX567A			

*5: For the installation method, refer to the section on "Indoor unit pipe connections" below.

Table. F (Indoor unit capacity comparison table - The indication of power is different depending on the model.)

Model code of indoor unit	04/004	07/007	09/009	12/012	14/014	18/018	24/024	30/030	34/034	36/036	45/045	54/054	60/060	72/072	90/090	96/096
Capacity [kW]	1.1	2.2	2.8	3.6	4.5	5.6	7.1	9.0	10.0	11.2	12.5	14.0	18.0	22.4	25.0	28.0

In the case of ARXD007GLEH: equivalent to model code of indoor unit Model code 007 → Capacity=2.2 kW

Outdoor air unit

Connectable unit within 1 refrigerant system

Unit	Connectable cooling capacity range	Remarks
Only Outdoor air unit	50% to 100%	-
Outdoor air unit + Indoor unit	50% to 100%	The capacity of "Outdoor air unit" should be less than 30% of the outdoor unit capacity.

4.3. Downsizing of pipe diameter

Note:

Reducers are field supplied.

- Downsizing of the liquid and gas pipe can be done in "4.2 Pipe selection", if pipe length is limited as below in "4.1 System configuration".
- Allowable downsizing are indicated by "→" in table A2, B2, C2, D2.

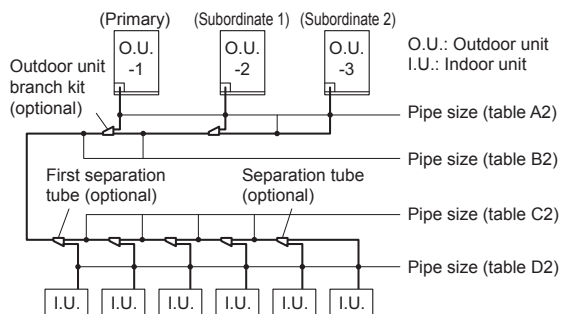
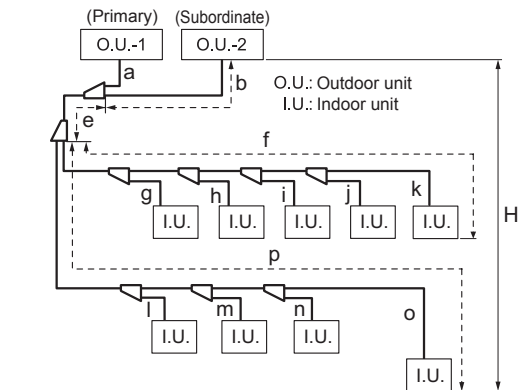

A (between outdoor unit and outdoor unit branch kit)

Allowable pipe length (actual pipe length)

* (+e): applies to multiple outdoor units connections.

Between primary outdoor unit and the farthest indoor unit	70 m or less	a (+e)+f, a (+e)+p
Between outdoor unit and indoor unit (When outdoor unit is installed below) * Only when the size of the liquid pipe goes down.	5 m or less	H

Table. A2

HP	Outdoor unit cooling capacity (kW)	Outside diameter (mm)	
		Liquid pipe	Gas pipe
8	22.4	12.70 (1/2") → 9.52 (3/8")	22.22 (7/8") → 19.05 (3/4")
10	28.0	12.70 (1/2") → 9.52 (3/8")	22.22 (7/8")
12	33.5	12.70 (1/2")	28.58 (1-1/8")
14	40.0	12.70 (1/2")	28.58 (1-1/8")
16	45.0	12.70 (1/2")	28.58 (1-1/8")
18	50.0	15.88 (5/8")	28.58 (1-1/8")

B (between outdoor unit branch kits or outdoor unit branch kit and first separation tube)

Allowable pipe length (actual pipe length)

* (+e): applies to multiple outdoor units connections.

Between primary outdoor unit and the farthest indoor unit	70 m or less	a (+e)+f, a (+e)+p
Between outdoor unit and indoor unit (When outdoor unit is installed below) * Only when the size of the liquid pipe goes down.	5 m or less	H

Table. B2

Total cooling capacity of outdoor unit (kW)	Outside diameter (mm)	
	Liquid pipe	Gas pipe
22.4	12.70 (1/2") → 9.52 (3/8")	22.22 (7/8") → 19.05 (3/4")
22.5 to 28.0	12.70 (1/2") → 9.52 (3/8")	22.22 (7/8")
28.1 to 45.0	12.70 (1/2")	28.58 (1-1/8")
45.1 to 56.0	15.88 (5/8")	28.58 (1-1/8")
56.1 to 62.4	15.88 (5/8")	34.92 (1-3/8") → 28.58 (1-1/8")
62.5 to 80.0	15.88 (5/8")	34.92 (1-3/8")
80.1 to 96.0	19.05 (3/4")	34.92 (1-3/8")
96.1 or more	19.05 (3/4")	41.27 (1-5/8")

C (between separation tubes)

Allowable pipe length (actual pipe length)

* (+e): applies to multiple outdoor units connections.

Between primary outdoor unit and the farthest indoor unit	120 m or less	a (+e)+f, a (+e)+p
Between the first separation tube and the farthest indoor unit	60 m or less	f, p
Between outdoor unit and indoor unit (When outdoor unit is installed below) * Only when the size of the liquid pipe goes down.	5 m or less	H

Table. C2

Total cooling capacity of indoor unit (kW)	Outside diameter (mm)	
	Liquid pipe	Gas pipe
2.2 to 11.1	9.52 (3/8")	15.88 (5/8")
11.2 to 13.9	9.52 (3/8")	19.05 (3/4") → 15.88 (5/8")
14.0 to 19.6	12.7 (1/2")	19.05 (3/4")
19.7 to 22.3	12.7 (1/2")	22.22 (7/8") → 19.05 (3/4")
22.4 to 28.0	12.7 (1/2")	22.22 (7/8")
28.1 to 32.4	12.7 (1/2")	28.58 (1-1/8") → 22.22 (7/8")
32.5 to 44.7	12.7 (1/2")	28.58 (1-1/8")
44.8 to 47.0	15.88 (5/8") → 12.7 (1/2")	28.58 (1-1/8")
47.1 to 56.0	15.88 (5/8")	28.58 (1-1/8")
56.1 to 71.6	15.88 (5/8")	34.92 (1-3/8") → 28.58 (1-1/8")
71.7 to 80.0	15.88 (5/8")	34.92 (1-3/8")
80.1 to 95.0	19.05 (3/4")	34.92 (1-3/8")
95.1 to 103.0	19.05 (3/4")	41.27 (1-5/8") → 34.92 (1-3/8")
103.1 or more	19.05 (3/4")	41.27 (1-5/8")

(If pipe diameter C2 > B2, select pipe size from table B2.)

D (between separation tubes to indoor unit)

Allowable pipe length (actual pipe length)

* (+e): applies to multiple outdoor units connections.

Between primary outdoor unit and the farthest indoor unit	120 m or less	a (+e)+f, a (+e)+p
Between the first separation tube and the farthest indoor unit	60 m or less	f, p
Between separation tube and indoor unit (1.1~2.8 kW only)	20 m or less	g, h, i, j, k, l, m, n, o
Between outdoor unit and indoor unit (When outdoor unit is installed below) * Only when the size of the liquid pipe goes down.	5 m or less	H

Table. D2

Model code	Cooling capacity of indoor unit (kW)	Outside diameter mm (in)	
		Liquid pipe	Gas pipe
04, 07, 09	1.1, 2.2, 2.8	6.35 (1/4")	12.70 (1/2") → 9.52 (3/8")
12, 14	3.6, 4.5	6.35 (1/4")	12.70 (1/2")
18	5.6	9.52 (3/8") → 6.35 (1/4")	15.88 (5/8") → 12.7 (1/2")
24, 30, 34	7.1, 9.0, 10.0	9.52 (3/8")	15.88 (5/8")
36, 45, 54	11.2, 12.5, 14.0	9.52 (3/8")	19.05 (3/4") → 15.88 (5/8")
60	18.0	9.52 (3/8")	19.05 (3/4")
72	22.4	12.7 (1/2") → 9.52 (3/8")	22.22 (7/8") → 19.05 (3/4")
90, 96	25.0, 28.0	12.7 (1/2") → 9.52 (3/8")	22.22 (7/8")

* Downsizing of pipes other than mentioned above by "→" is not allowed.

4.4. Protection of pipes

- Protect the pipes to prevent the entry of moisture and dust.
- Especially pay attention when passing the pipes through a hole or connecting the end of a pipe to the outdoor unit.

Location	Working period	Protection method
Outdoor	1 month or more	Pinch pipes
	Less than 1 month	Pinch or tape pipes
Indoor	—	Pinch or tape pipes

5. PIPE INSTALLATION

5.1. Brazing

CAUTION

If air or another type of refrigerant enters the refrigeration cycle, the internal pressure in the refrigeration cycle will become abnormally high and prevent the unit from exerting its full performance.

Apply nitrogen gas while brazing the pipes.
Nitrogen gas pressure: 0.02 MPa (= pressure felt sufficiently on the back of your hand)

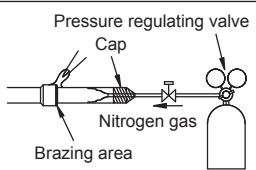

If a pipe is brazed without applying nitrogen gas, it will create an oxidation film. This can degrade performance or damage the parts in the unit (such as the compressor or valves).

Do not use flux to braze pipes. If the flux is the chlorine type, it will cause the pipes to corrode. In addition, if the flux contains fluoride, it will affect the refrigerant piping system due to deterioration of refrigerant oil.

For brazing material, use phosphor copper that does not require flux.

5.2. Indoor unit pipe connections

CAUTION

For details, refer to the Installation Instruction Sheet of each part.

Separation tube

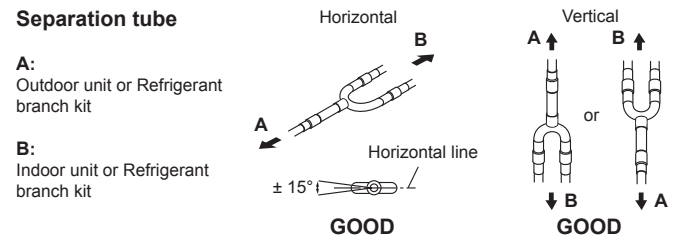

PROHIBITED

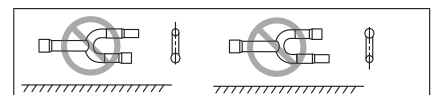

Header

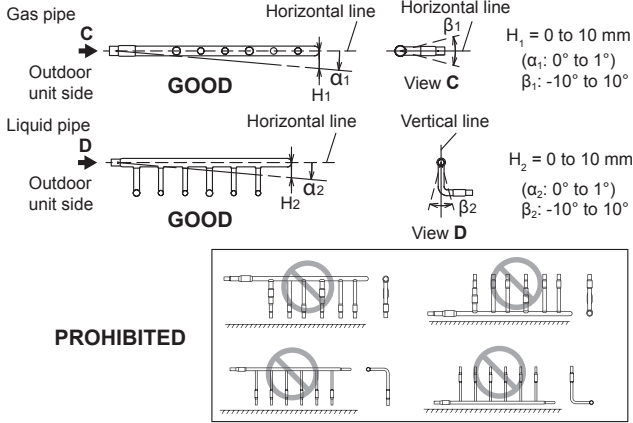

CAUTION

Do not connect a separation tube after a header.

Leave the distance 0.5 m or more for straight part to branch tube and header.

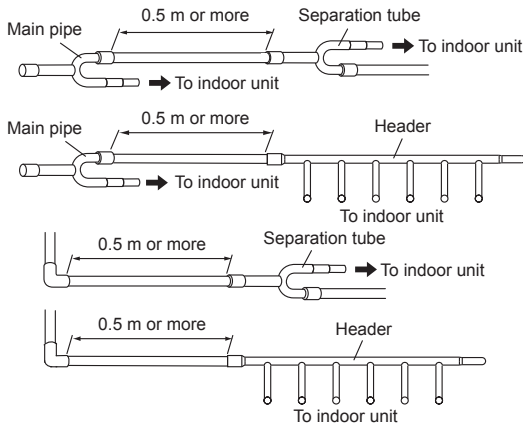

5.3. Opening the knockout hole

CAUTION

Be careful to prevent panel deformation or damaged while opening the knockout hole.

To prevent cutting of the wiring after the knockout hole was opened, remove the burrs along the edge.

In addition, to prevent rusting, painting the edge with rust preventive paint is recommended.

The piping can be connected from 2 directions; the front or the bottom. (Knockout holes are provided so that the piping can be connected from 2 different directions.)

Use the front knockout hole, as required.

Fig. A Knockout position

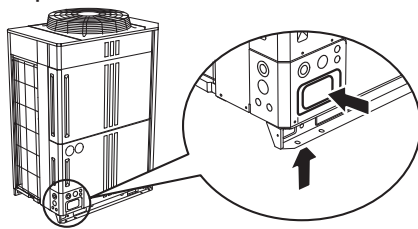

Fig B Detail of knockout position (bottom)

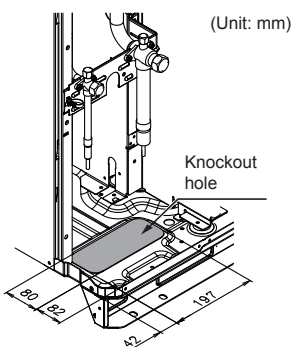
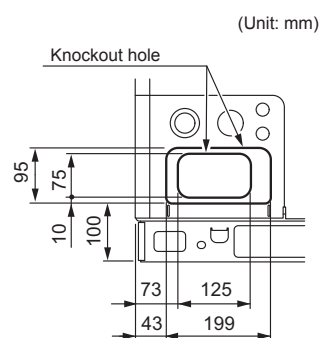

Fig C Detail of knockout position (front)



5.4. Pipe connection

CAUTION

Do not use mineral oil on a flared part. Prevent mineral oil from getting into the system as this would reduce the lifetime of the units.

While brazing the pipes, be sure to blow dry nitrogen gas through them.

The maximum lengths of this product are shown in the table. If the units are further apart than this, correct operation cannot be guaranteed.

5.4.1 Bending pipes

CAUTION

To prevent breaking of the pipe, avoid sharp bends. Bend the pipe with a radius of curvature of 100 mm or more.

If the pipe is bent repeatedly at the same place, it will break.

- If pipes are shaped by hand, be careful not to collapse them.
- Do not bend the pipes at an angle of more than 90°.
- When pipes are repeatedly bent or stretched, the material will harden, making it difficult to bend or stretch them anymore.
- Do not bend or stretch the pipes more than 3 times.

5.4.2 Removing the pinch pipe

WARNING

Remove the pinch pipe only when the internal gas is completely drained as shown on the below instructions. If gas still remains inside, the piping may crack if you melt the brazing filler metal of the junction area with a burner.

Before connecting the piping, remove the pinch pipe in accordance with the following instructions:

- (1) Verify that the liquid side, suction gas side and discharge gas side 3-way valves are closed.
- (2) Cut the end of the liquid side, suction gas side and discharge gas side pinch pipe and vent the gas inside the pinch pipe.
- (3) After all the gas is vented, melt the brazing filler metal on connecting part using a torch and remove the pinch pipe.

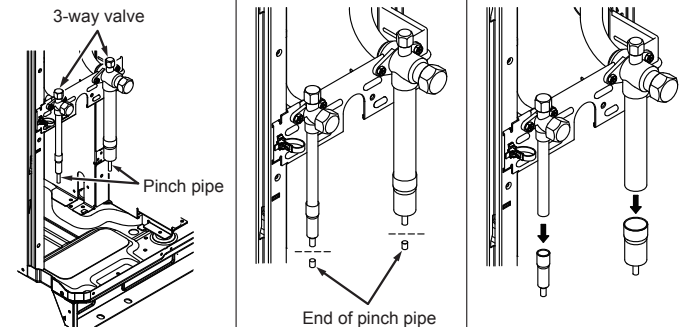

5.4.3 Pipe connection

CAUTION

Seal the pipe route hole with putty (Locally purchased) such that there are no gaps. Small insects or animals that are trapped in the outdoor unit may cause a short circuit in the electrical component box.

To prevent pipe damage; do not make sharp bends. Bend the pipe at a radius of 70 mm or greater.

Do not bent pipe many times at same part to prevent break.

After completing all the pipe connection by brazing, perform the indoor unit pipe connection with a flare joint.

When removing the pinch pipe or brazing the joint pipe, carry out the work while cooling down the 3-way valve sufficiently.

- Braze the joint pipe onto the 3-way valves at the liquid, suction gas and discharge gas side.
- Install the joint pipe appropriately so that it can be connected easily with the main pipe.
- Braze the joint pipe at the liquid, suction gas and discharge gas side with the main pipe.
- * Be sure to supply nitrogen when brazing.

Fig. A

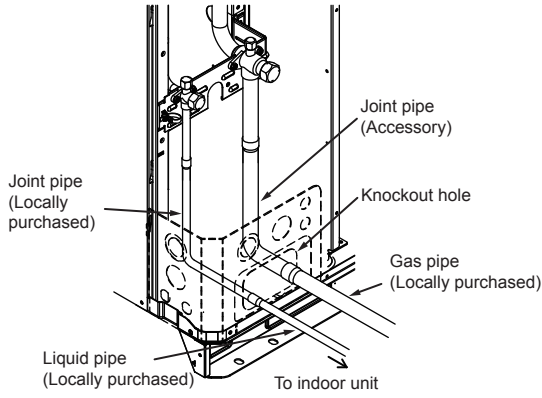
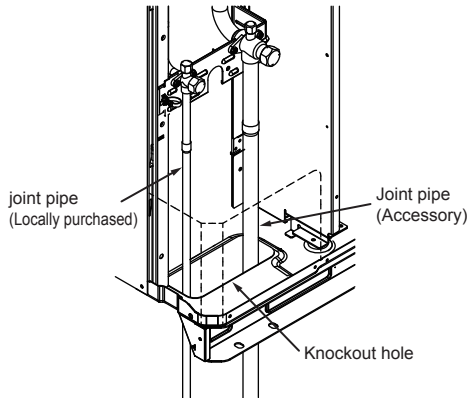

Fig. B



5.5. Multiple connections

CAUTION

- When connecting multiple (maximum 3) units, be sure to install the unit with the largest capacity nearest to the indoor unit.
For example: AJ*126LALDH (Outdoor Unit1) + AJ*126LALDH (Outdoor Unit2) + AJ*090LALDH (Outdoor Unit3)
- When connecting multiple units, set the unit with the largest capacity as the primary unit, and the rest as the subordinate units. (Refer to "7. FIELD SETTING")
- When connecting multiple units, use the optional outdoor unit branch kit.

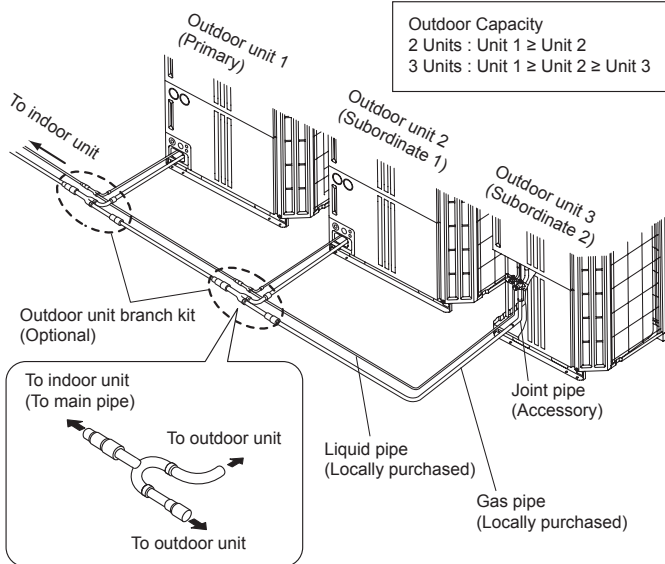

Branch kit restriction when install

Be sure following restriction.

(1) Installation angle

Install the outdoor unit branch kit horizontally level, within 0° to -10°, so that the refrigerant separates evenly.

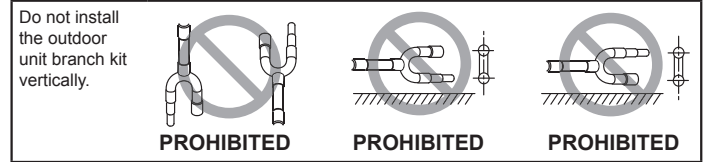
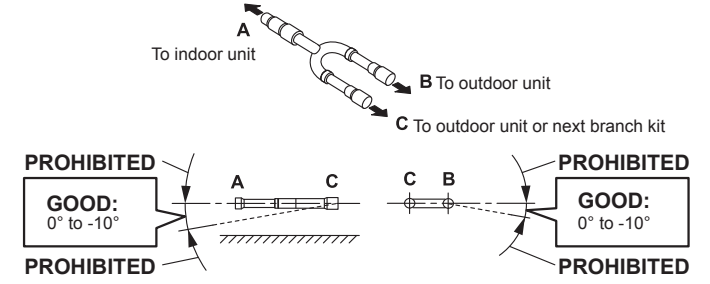

(2) Straight pipe length

Leave the distance 0.5 m or more for straight part to outdoor unit branch kit.

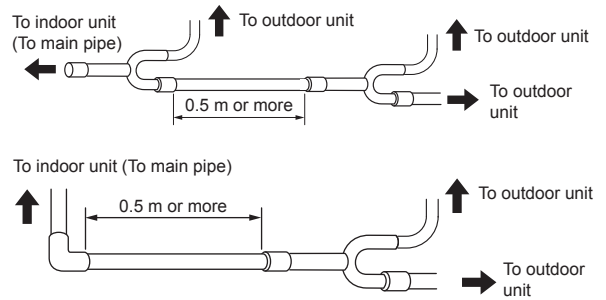

(3) About the connecting curvature of field pipe and branch kit:

The field pipe should be connected to the branch kit so that the curved angle on each side is 3 degree or less.

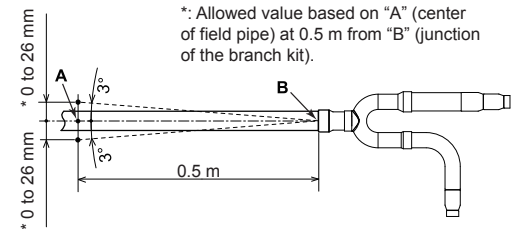

*: Allowed value based on "A" (center of field pipe) at 0.5 m from "B" (junction of the branch kit).

(4) For details, refer to the Installation Instruction Sheet of the outdoor unit branch kit.

Examples of multiple unit installation

(Example 1) (Primary)

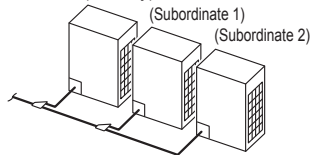

(Example 2) (Primary)

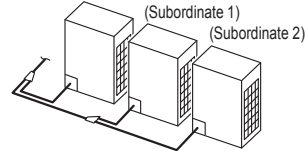

(Example 3)

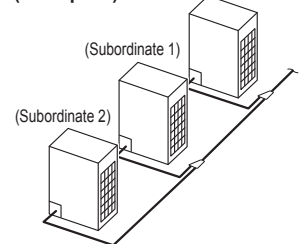

(5) Examples of multiple unit installation are shown below.

CAUTION

To prevent the oil from settling in the stopped unit, install the pipes between the outdoor units so that they are level or are tilted upward to the outdoor units.

Installable patterns

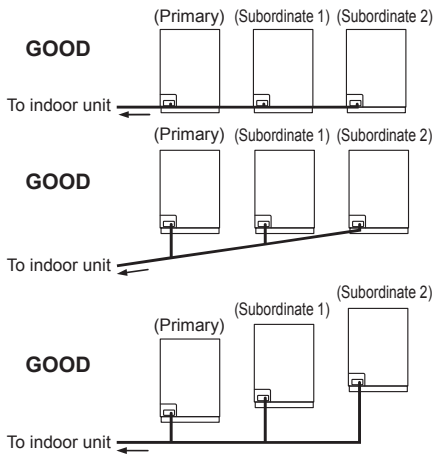

Non-installable patterns

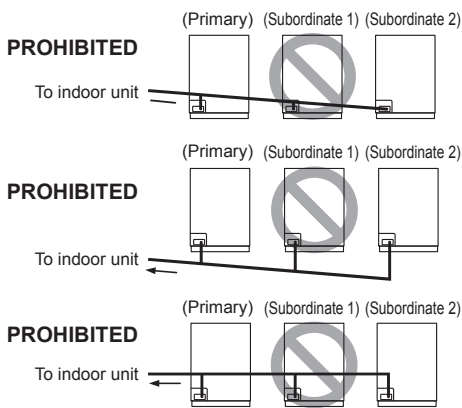

(6) If the pipe length between outdoor unit branch kit and outdoor unit branch kit (or subordinate unit) is longer than 2 m, or a lower pipe line exists between outdoor units, rise for gas pipe (Discharge gas pipe and Suction gas pipe) should be arranged to eliminate oil from entering into and remaining at pipes and the stopped outdoor unit. However, there is no need to provide a rise on the pipe connecting between the primary unit and the indoor unit even if the length exceeds 2 m.

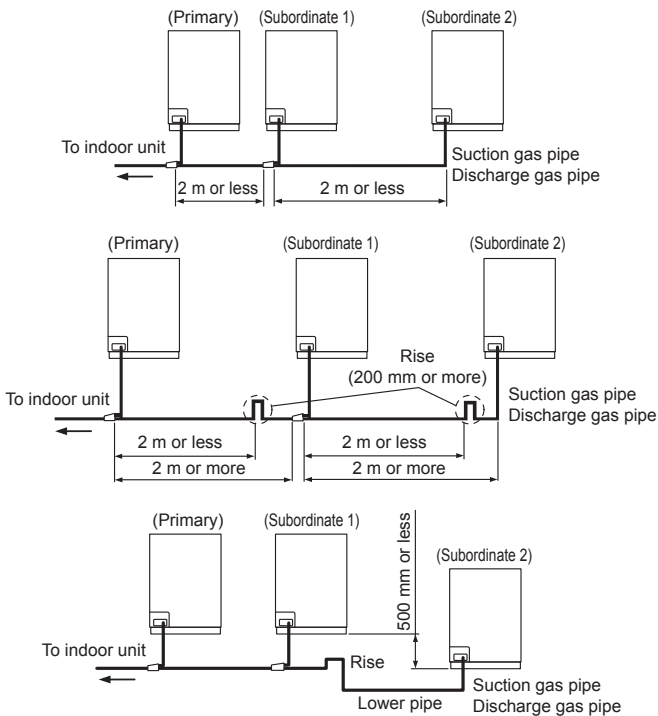

6. ELECTRICAL WIRING

6.1. The precautions of electrical wiring

WARNING

- Wiring connections must be performed by a qualified person in accordance with specifications.
- The rated supply of this product is 50 Hz, 400 V of 3-phase, 4-wire. Use a voltage within the range of 342 to 456 V.
- Make sure to perform earthing (grounding) work. Improper earthing (grounding) work can cause electric shocks.
- Before connecting the cables, make sure the power supply is OFF.
- Be sure to install an earth (ground) leakage breaker. Otherwise, it will cause electric shock or fire.
- Be sure to install a breaker of the specified capacity. When selecting breaker, please comply with the laws and the regulations of each country. One breaker must be installed on the power supply of the outdoor unit. Wrong selection and setup of the breaker will cause electric shock or fire.
- Do not connect AC power supply to the transmission line terminal board. Improper wiring can damage the entire system.
- Connect the connector cord securely to the terminal. Faulty installation can cause a fire.
- Do not modify power cable, use extension cable or branch wiring. Improper use may cause electric shock or fire by poor connection, insufficient insulation or over current.
- Make sure to secure the insulation portion of the connector cable with the cord clamp. A damaged insulation can cause a short circuit.
- Never install a power factor improvement condenser. Instead of improving the power factor, the condenser may overheat.
- Before servicing the unit, turn the power supply switch OFF. Then, do not touch electric parts for 10 minutes due to the risk of electric shock.
- Always use a separate power supply line protected by a circuit breaker operating on all cables with a distance between contact of 3 mm for this unit.
- Use Ring terminals and tighten the terminal screws to the specified torques, otherwise, abnormal overheating may be produced and possibly cause serious damage inside the unit.
- Securely install the electrical box cover on the unit. An improperly installed service panel can cause serious accidents such as electric shock or fire through exposure to dust or water.
- If the supply cable is damaged, it must be replaced by the manufacturer, its service agent or similarly qualified persons in order to avoid a hazard.

CAUTION

- The primary power supply capacity is for the air conditioner itself, and does not include the concurrent use of other devices.
- Connect the power cables in positive phase sequence. If they are connected in negative phase sequence, an error will be displayed. If there is a missing phase connection, the unit will not operate normally. Do not connect a N phase (neutral phase) cable to other phases (misconnection). Wrong wiring will lead to parts damage.
- Do not use crossover power supply wiring for the outdoor unit.
- If the electrical power is inadequate, contact your electric power company.
- Install a breaker (Included with earth leakage circuit breaker) in a location that is not exposed to high temperatures.
- If the temperature surrounding the breaker is too high, the amperage at which the breaker cuts out may decrease.
- Use a breaker (Included with earth leakage circuit breaker) that is capable of handling high frequencies. Because the outdoor unit is inverter controlled, a high-frequency breaker is necessary to prevent a malfunction of the breaker itself.
- When the electrical switchboard is installed outdoors, place it under lock and key so that it is not easily accessible.
- Never bundle the power supply cable and transmission cable, remote control cable together. Separate these cables by 50 mm or more. Bundling these cables together will cause miss operation or breakdown.
- Always keep to the maximum length of the transmission cable. Exceeding the maximum length may lead to erroneous operation.
- The static electricity that is charged to the human body can damage the control PC board when handling the control PC board for address setting, etc. Please keep caution to the following points.
- Provide the earthing (grounding) of Indoor unit, Outdoor unit and Option equipment. Cut off the power supply (breaker).
- Touch the metal section (such as the unpainted control box section) of the indoor or outdoor unit for more than 10 seconds. Discharge the static electricity in your body. Never touch the component terminal or pattern on the PC board.

6.2. Wiring method

6.2.1 Connection diagrams

The wiring example for outdoor units and indoor units is shown in the figure.

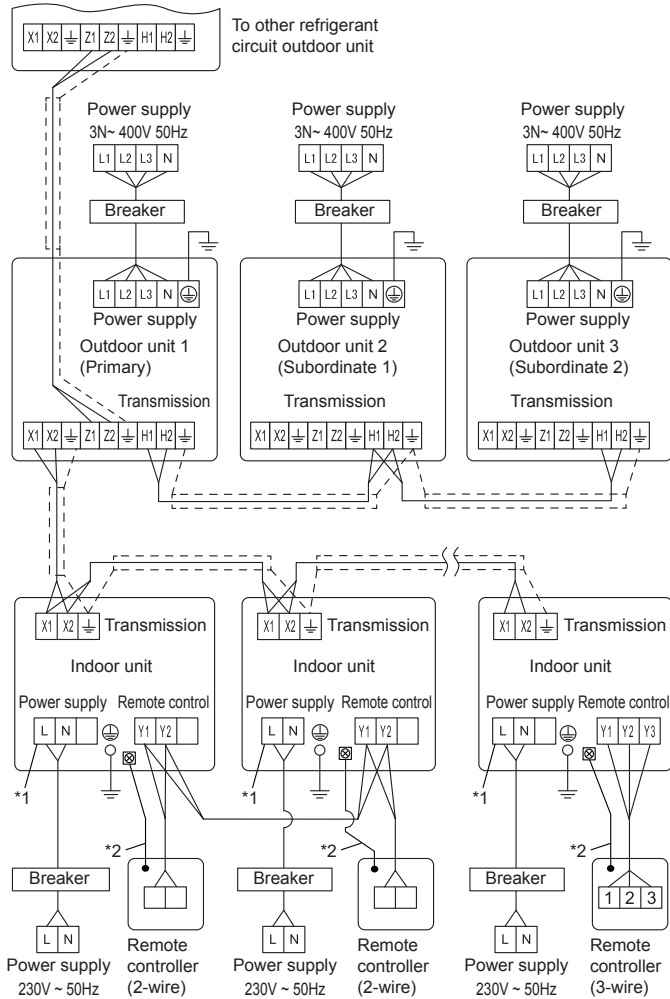

- *1: The number of power supply terminals is different depending on the indoor unit model. For the wiring, refer to the indoor unit installation manual.
- *2: Earth (Ground) the remote controller if it has an earth (ground) cable.
- There are two types of remote controller: the 2-wire type and the 3-wire type. For details, see the relevant remote controller installation manual. (When connecting the 2-wire type remote controller, Y3 is not used.)

6.3. Knockout hole

CAUTION

Seal the wiring route hole with putty (Locally purchased) such that there are no gaps. Small insects or animals that are trapped in the outdoor unit may cause a short circuit in the electrical component box.

Be careful not to deform or scratch the panel while opening the knockout holes.

After opening the knockout holes, remove burr on the edges, and attach the conduit or grommet edging (accessories) to prevent damaging the cables. It is recommended to apply rust proof paint on the edges to prevent rust.

Electric wires can be connected from the front or from the left.
(Knockout holes are prepared so that wiring can be made from 2 different directions.)
Use the knockout holes on the front and the left separately when necessary.

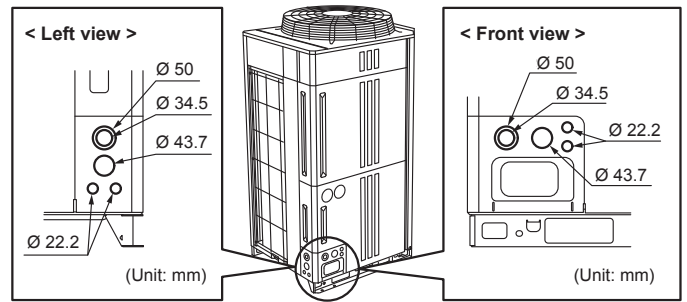

Length of the grommet edging

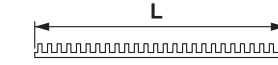

Knockout hole diameter (mm)	Dimension L (mm)
Ø 50	147
Ø 43.7	130
Ø 34.5	100
Ø 22.2	60

Mounting the grommet edging

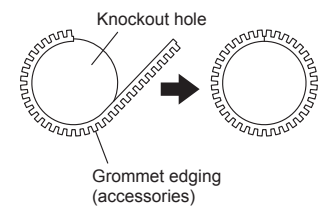

6.4. Selecting power supply cable and breaker

CAUTION

Obtain the distribution network operator's agreement about the power capacity of the power supply system, specification of the cable and the harmonic current, and etc. when you connect the outdoor unit with the power supply.

Regulation of wire size and circuit breaker differs from each locality, please refer in accordance with local rules.

Refer to the table for the wiring and breaker specifications of each installation condition.

(1) Selecting power supply cable and breaker when connecting 1 outdoor unit

Model	Breaker (Time delay fuse or circuit capacity)		Outdoor unit power supply cable		
	Fuse capacity (A)	Leakage current	Recommended cable size (mm ²)		Limited wiring length (m)
			Power cable	Earth (ground) cable	
AJ*072LALDH	20	100 mA 0.1 sec or less	6	6	62
AJ*090LALDH	25		6	6	62
AJ*108LALDH	25		6	6	62
AJ*126LALDH	40		10	10	64
AJ*144LALDH	40		10	10	64

These values are recommended data.

- Specification: Use conformed cord with Type 60245 IEC66
- Max. wire length: Set a length so that the voltage drop is less than 2%. Increase the wire diameter when the wire length is long.

In case of connected outdoor unit

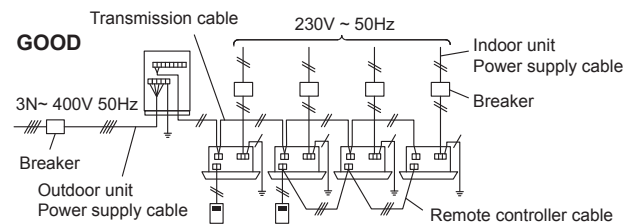

(2) Selecting main breaker and main power supply cable when connecting multiple outdoor units

In case of connected 3 outdoor unit

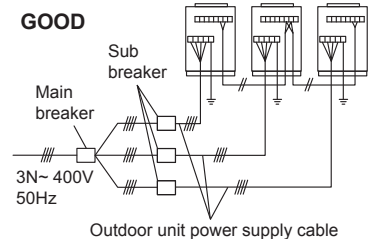

Main breaker: Main breaker \geq Total Sub breaker
(Refer to the table in item (1) for the sub breaker capacity)

PROHIBITED

Breaker
PROHIBITED: install a breaker for each outdoor unit

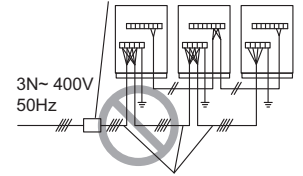

Outdoor unit power supply cable
PROHIBITED: crossover power supply wiring prohibited

6.5. Transmission line

CAUTION

Caution when wiring cable:

When stripping off the coating of lead wire, always use the exclusive tool such as a wire stripper. If there is no exclusive tool available necessarily, carefully strip the coating by a cutter etc. so that the conductive wire is not damaged. If it is damaged, it may lead to an open circuit and a communication error.

Pay attention to the following points while attaching wires on the terminal board.

- Do not attach 2 wires on one side.
- Do not twist wires.
- Do not cross the wires.
- Do not shorted at edge at root.

GOOD

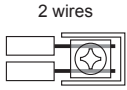
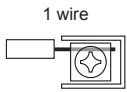

PROHIBITED

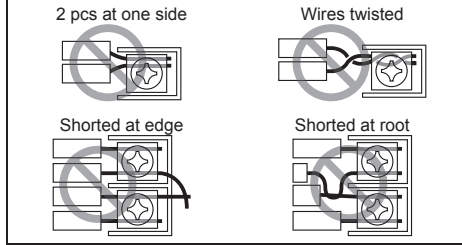

6.5.1 Transmission wiring specifications

Follow the specifications below for the transmission cable.

Use	Size	Cable type	Remarks
Transmission cable	0.33 mm ²	22AWG LEVEL 4 (NEMA) non-polar 2 core, twisted pair solid core diameter 0.65 mm	LONWORKS® compatible cable

Twisted pair with shielded type.

Use the shielded wire specified and always ground it both ends.

6.5.2 Wiring rules

(1) Total length of transmission cable

Total transmission line length : Max. 3,600 m

$EF + EG + GH + HJ + HK + KL < 3,600$ m (Fig.2)

In the following cases, Signal Amplifier is required.

When the total length of the transmission line exceeded 500 m.

- 1) $AB + BC + BD > 500$ m (Fig.1)
- 2) When the total number of units* is over 64.
- 3) Transmission line length between each unit* ≥ 400 m

(2) Length of transmission cable between 1 network segment (NS)

$EF + EG + GH + HJ + HK \leq 500$ m (Fig.2)

$KL \leq 400$ m (Fig.2)

(3) Length of transmission cable between outdoor units in a refrigerant system

$MN \leq 18$ m

$NP \leq 18$ m

Fig. 1

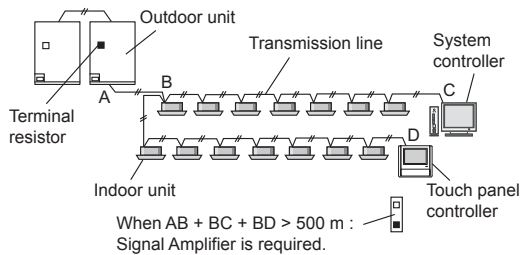
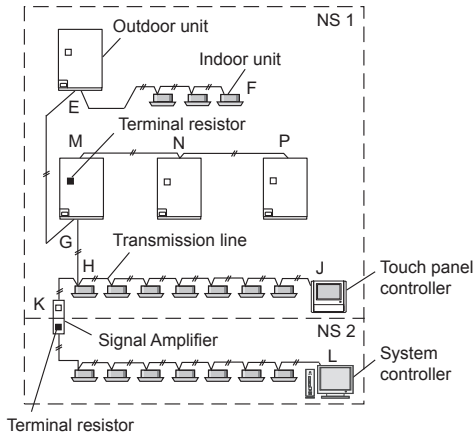

Fig. 2



NOTES

• Unit* means indoor unit, outdoor unit, Touch Panel Controller and System Controller, Signal Amplifier, single split adaptor, Network Converter etc.

• Do not use loop wiring. This may lead to parts damage and erroneous operation.

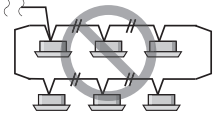

6.5.3 Enabling/Disabling automatic address setting

You can enable/disable automatic address setting for the indoor unit, RB unit and the signal amplifier.

To enable automatic address setting for the indoor unit, connect the indoor unit to outdoor units under the same refrigerant system.

Example:
Disable Auto-
matic Address
setting

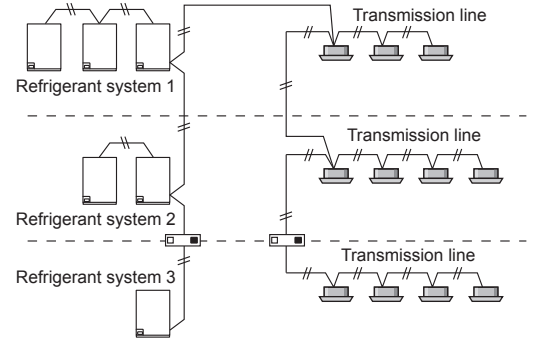

Example:
Enable Auto-
matic Address
setting

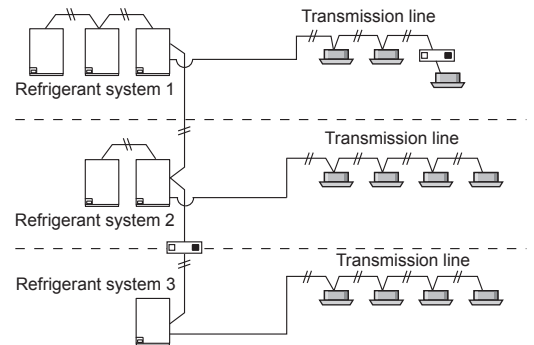

6.6. Wiring procedure

- Remove the cover of the electrical compartment and follow the terminal plate to connect the electric cables to the terminal.
- After connecting the cables, secure them with the cable ties.
- Connect the cables without applying excessive tension.

6.6.1 Cable routing

Secure with a cable tie as shown in the figure below.

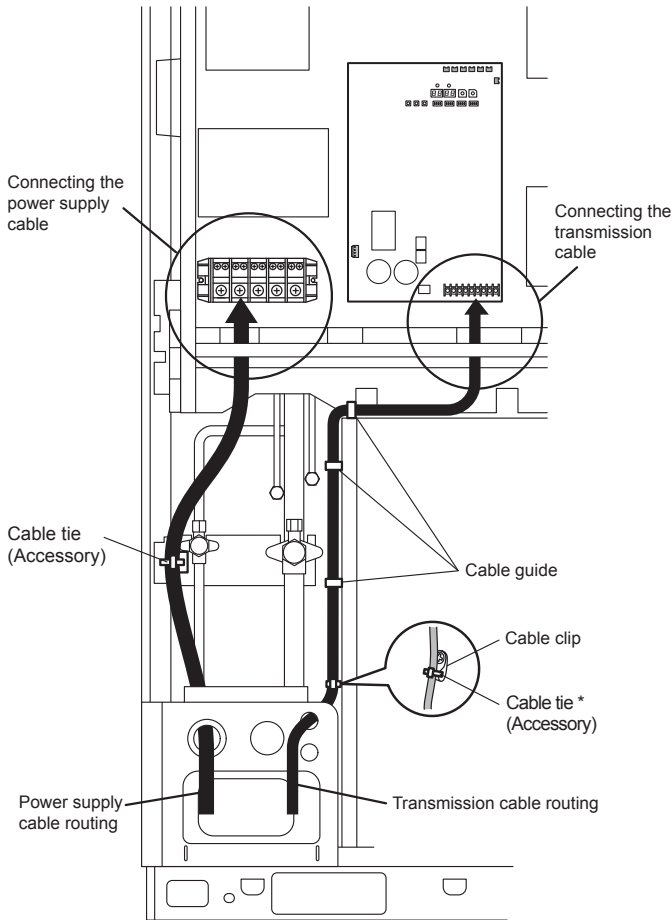

* Tighten the cable tie firmly so that pulling force does not propagate to the terminal connection even if force of 100 N is applied to the cable.

6.6.2 Connecting cables to the terminals

⚠ WARNING

Use ring terminals and tighten the terminal screws to the specified torques, otherwise, abnormal overheating may be produced and possibly cause heavy damage inside the unit.

Be sure fill the holes of power supply cable and transmission cable with putty (Locally purchased).
If small animals such as insects enter the electrical component box, a short circuit may be caused.

Tightening torque

M3 screw	0.5 to 0.6 N·m (5 to 6 kgf·cm)
M8 screw	5.0 to 7.0 N·m (50 to 70 kgf·cm)

How to connect wiring to the terminal

Caution when wiring cable

- Use ring terminals with insulating sleeves as shown in the figure to connect to the terminal block.
- Securely clamp the ring terminals to the cables using an appropriate tool so that the cables do not come loose.
- Use the specified cables, connect them securely, and fasten them so that there is no stress placed on the terminals.
- Use an appropriate screwdriver to tighten the terminal screws. Do not use a screwdriver that is too small, otherwise, the screw heads may be damaged and prevent the screws from being properly tightened.
- Do not tighten the terminal screws too much, otherwise, the screws may break.
- See the table below for the terminal screw tightening torques.

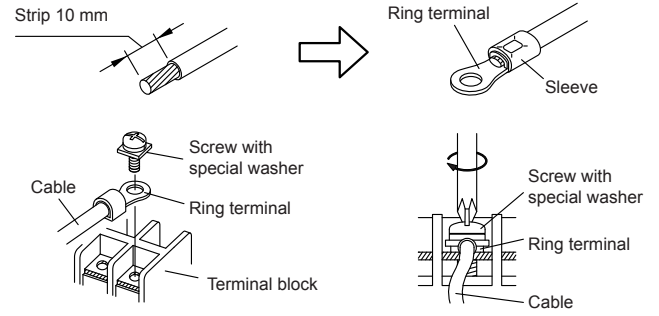

6.6.3 Connecting the power supply cable

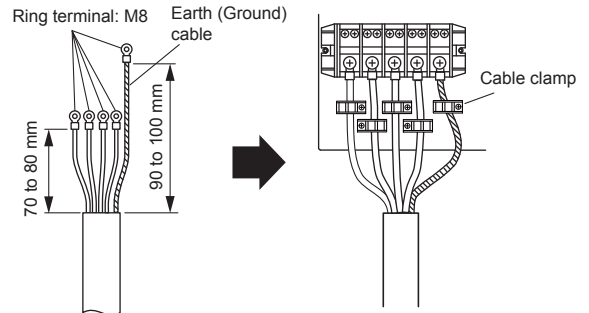

* Use a ring terminal to connect the electric cables to the power supply terminal board.

6.6.4 Connecting the transmission cable

Shielding the transmission cable

Connect both ends of the shielded wire of the transmission cable to the earth (ground) terminal of the equipment or to the earth (ground) screw near the terminal.

Be sure to use one side of a twisted-pair cable when using transmission cable with 2 sets of twisted-pair cables.

Wind with insulation tape to prevent short circuit

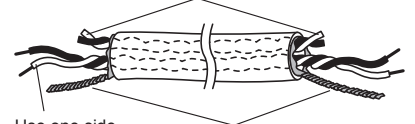

Use one side of the twisted pair cable

Connect both ends of shielded wire to earth (Ground).

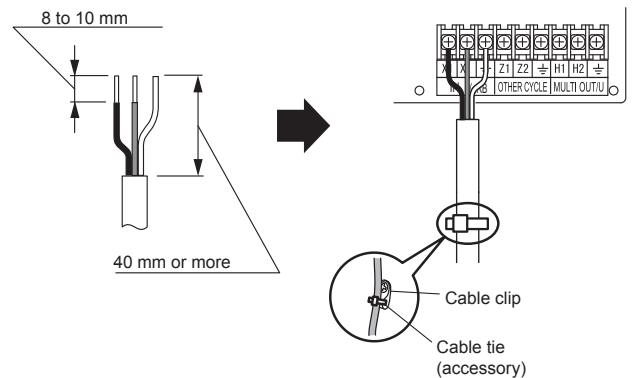

6.7. External input and external output

6.7.1 Terminal position

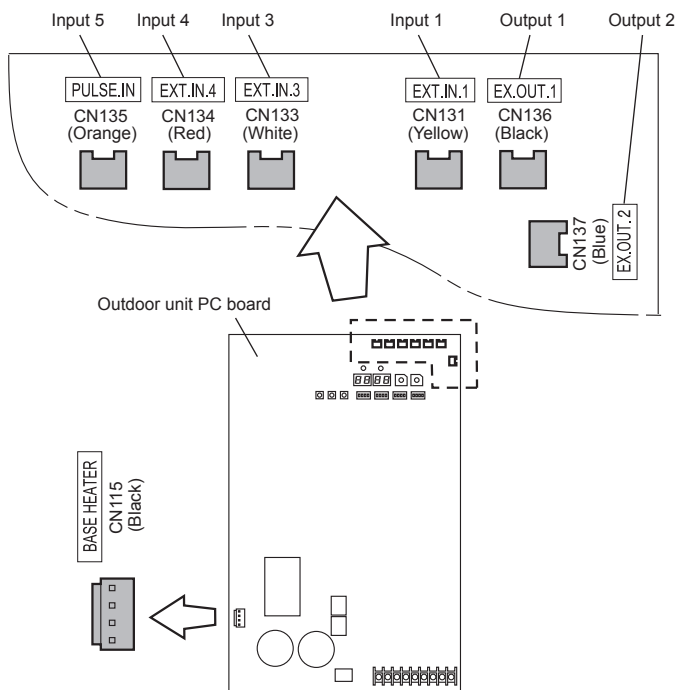

CAUTION
Do not bundle the cable for base heater with other cables.

(Example)

- In case of Outdoor unit
- Insert the connector to CN134 (Red) and CN135 (Orange) of control PC board.
 - Fix it to the wire with the attached cable tie.

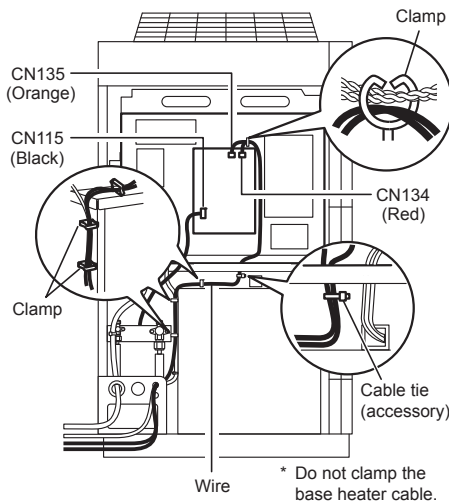

6.7.2 External input terminal

- Setting to low noise mode, outdoor unit operation peak control setting, emergency/batch stop and electricity meter pulse are possible from the outside.
- Except for wattmeter pulse reception (CN135) among external input terminals, only the primary unit is effective.

Wiring method and specifications

- A twisted pair cable (0.33 mm² (22AWG)) should be used. Maximum length of cable is 150 m.
- Use an external input and output cable with appropriate external dimension, depending on the number of cables to be installed
- For each input, pin No. 1 is of positive polarity and pin No. 2 is of ground level.

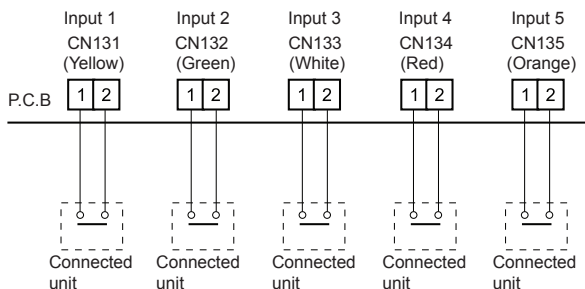

Operation behavior

Each input terminal works as follows.

Connector	Input signal	Status	Outdoor unit	
			Primary	Subordinate
Input 1 CN131 (Yellow)	OFF	Normal operation	○	×
	ON	Low noise mode operation		
Input 2 CN132 (Green) (*1)	OFF	Cooling priority	○	×
	ON	Heating priority		
Input 3 CN133 (White)	OFF	Normal operation	○	×
	ON	Outdoor unit operation peak control		
Input 4 CN134 (Red)	OFF	Normal operation	○	×
	ON	Batch stop or Emergency stop operation *2, *3		
Input 5 CN135 (Orange) (*4)	No pulse	No information from electricity meter	○	○
	Pulse	Power usage information from electricity meter		

Subordinate unit can connect only input 5 (CN135).

The operations of each input terminal and the selection of function are set with the push button on the PC board of outdoor unit. About the setting, please refer to "7. 4. Push button setting".

NOTES:

- *1: The "external input priority mode" must be set by pressing push button on PC board of outdoor unit. (Refer to "7. FIELD SETTING".)
- *2: Batch stop or Emergency stop pattern can be selected by outdoor unit PC board push button. (Refer to "7. FIELD SETTING".)
- *3: The emergency stop function mounted in this model does not guarantee the regulations of each country. For this reason, sufficient checking is necessary regarding use. Especially, since the fact that the equipment may not be emergency-stopped in the case of breaking of the wiring to the external input terminals and communication line, communication error due to noise, VRF external input circuit trouble, etc. must be considered, the provision of double measures that add direct interruption of the power supply by switch, etc. is recommended as a precaution.

6.7.3 External output terminal (primary unit only)

- You can detect the operation condition of outdoor unit and the abnormal situation of both indoor and outdoor unit.
- The external output terminal is only valid for primary unit.

Wiring method and specifications

Error status

This output indicates the outdoor unit and connected indoor unit's "Normal" or "Error" status.

Operation status

This output indicates the outdoor unit's "Operation" status.

Connector	Output voltage	Status
Output 1 CN136 (Black)	0 V	Normal
	DC 12-24 V (*1)	Error
Output 2 CN137 (Blue)	0 V	Stop
	DC 12-24 V (*1)	Operation

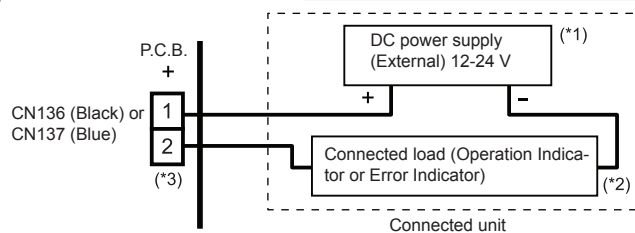

- *1: Provide a DC 12 to 24 V power supply. Select a power supply capacity with an ample surplus for the connected load.
- *2: The allowable current is 30 mA or less. Provide a load resistance such that the current becomes 30 mA or less.
- *3: Polarity is [+] for pin 1 and [-] for pin 2. Connect correctly. Do not impress a voltage exceeding 24 V across pins 1-2.

- A twisted pair cable (0.33 mm² (22AWG)) should be used. Maximum length of cable is 150 m.
- Use an external input and output cable with appropriate external dimension, depending on the number of cables to be installed.

6.7.4 Base heater terminal

This is the output signal for base heater. Output signal ON, when the outdoor temperature goes down below 2°C, and signal OFF at the outdoor temperature 4°C.

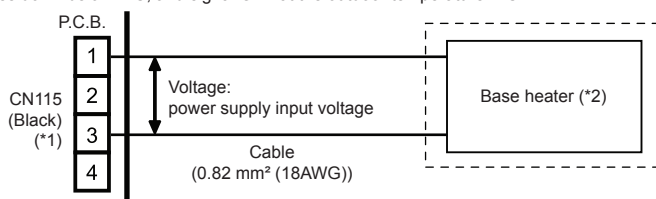

- *1: Connect to pin 1 and pin 3. No connection pin 2 and pin 4.
- *2: The allowable current is 1 A or less.

7. FIELD SETTING

CAUTION

Discharge the static electricity from your body before setting up the DIP switches. Never touch the terminals or the patterns on the parts that are mounted on the PC board.

7.1. Field setting switches

Remove the service panel of the outdoor unit and the cover of the electrical component box to access the PC board of the outdoor unit. PC board switches for various settings and LED displays are shown in the figure.

7.2. DIP switch setting

7.2.1 List of Settings

SET3 and SET5 must be set for the DIP switch. Configure the settings before turning on the power. Settings for SET1, SET2, and SET4 DIP switches are factory default ones. Do not change them.

DIP Switch	Function	
SET 1	1-4 Prohibited	
SET 2	1-4 Prohibited	
SET 3	1	Outdoor unit address setting
	2	
	3	Setting for number of subordinate units
	4	
SET 4	1-4 Prohibited	
SET 5	1-2	Number of outdoor units installed
	3	
	4	
	4	

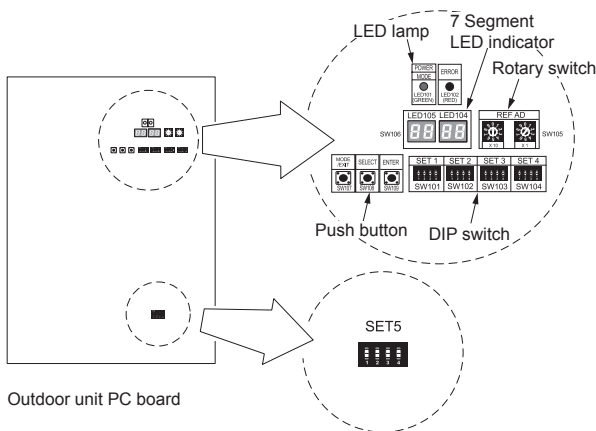

Outdoor unit PC board

7.2.2 Settings to be configured locally

(1) Outdoor unit address setting

When 2 or 3 outdoor units are installed to 1 refrigerant system, set the address for each outdoor unit. Set the address for all outdoor units.

SET3		Outdoor unit address	Remarks
1	2		
OFF	OFF	0	Primary unit (Factory setting)
OFF	ON	1	Subordinate unit 1
ON	OFF	2	Subordinate unit 2
ON	ON	-	Prohibited

(2) Number of subordinate units setting for outdoor unit

Set the number of subordinate units connected to 1 refrigerant system. Set only the primary unit.

SET3		Number of connectable outdoor units	Remarks
3	4		
OFF	OFF	0	Primary unit only (Factory setting)
OFF	ON	1	1 subordinate unit connected
ON	OFF	2	2 subordinate unit connected
ON	ON	-	Prohibited

(3) Number of outdoor units installed

The number of outdoor units installed in 1 refrigerant system must be set. Set for all outdoor units.

SET5		Number of outdoor units	Remarks
1	2		
OFF	OFF	1	(Factory setting)
OFF	ON	2	-
ON	OFF	3	-
ON	ON	-	Prohibited

7.2.3 Terminal resistor setting

CAUTION

Be sure to set the terminal resistor according to specifications. Set the terminal resistor for every network segment (NS).

If terminal resistor is set in multiple devices, the overall communication system may be damaged. If terminal resistor is not set in a device, abnormal communication may occur.

- Be sure to set 1 terminal resistor in a network segment. You can set the terminal resistor at the outdoor unit or signal amplifier.
- When setting the terminal resistor of a signal amplifier, refer to the installation manual of the signal amplifier.
- When setting multiple terminal resistors, take note of the following items.
 - How many network segments are there in a VRF system?
 - Where will you set the terminal resistors in a network segment? (Condition for 1 segment: Total number of outdoor and indoor units and signal amplifiers is less than 64, or the total length of the transmission cable is less than 500 m)
 - How many outdoor units are connected to 1 refrigerant system?

Configure the setting (DIP switch SET5) of the terminal resistor of the outdoor units as shown below from conditions (1) to (3).

SET5	Terminal resistor	Remarks
4		
OFF	Disable	(Factory setting)
ON	Enable	—

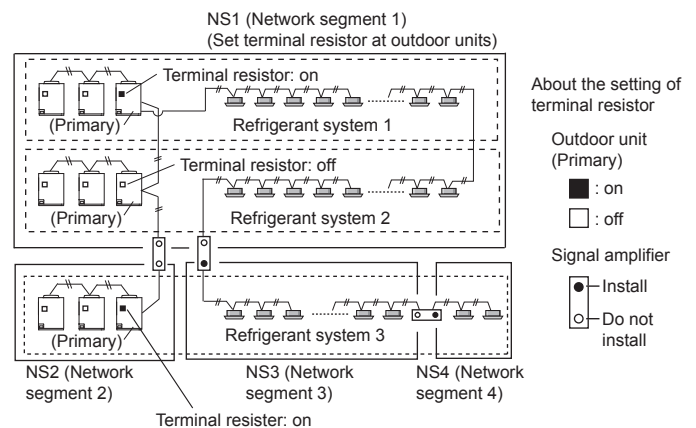

7.3. Rotary switch setting

The rotary switch (REF AD) sets the refrigerant circuit address of the outdoor unit. Configure the settings only on the primary unit of a refrigerant system. If multiple refrigerant systems are connected, set the rotary switch (REF AD) as shown in the table below.

Refrigerant circuit address	Rotary Switch Setting		Setting range	Type of switch
	REF AD			
	x10	x1		
0	0	0	0 to 99 Setting example 63	
1	0	1		
2	0	2		
⋮	⋮	⋮		
98	9	8		
99	9	9		

Rotary Switch (REF AD × 1): Factory setting "0"
Rotary Switch (REF AD × 10): Factory setting "0"

7.4. Push button setting

Various functions can be set when necessary. Perform settings after all indoor units have stopped operation.

List of Settings

No	Setting Item	7-segment display		Factory default	
		First 2 digits	Last 2 digits		
00	Pipe length setting (*1)	0	0	0 0	●
				0 1	
				0 2	
				0 3	
				0 4	
Pipe length means the length between primary outdoor unit and the nearest indoor unit.					
10	Sequential start shift (*1)	1	0	0 0	●
				0 1	
				0 2	
				0 3	
The start-up timing of outdoor unit (compressor) can be set up so that it can delay several seconds. This feature is useful when multiple number of outdoor units are installed and turned on at the same time to limit the starting current.					

11	Cooling capacity shift (*1)	Normal mode	1	1	0	0	●
		Save energy mode			0	1	
		High power mode 1			0	2	
		High power mode 2			0	3	
		Prohibited			0	4	
Set this item when necessary.							
12	Heating capacity shift (*1)	Normal mode	1	2	0	0	●
		Save energy mode			0	1	
		High power mode 1			0	2	
		High power mode 2			0	3	
		Set this item when necessary.					
13	Prohibited (Factory default)		1	3	0	0	●
14	Prohibited (Factory default)		1	4	0	0	●
15	Prohibited (Factory default)		1	5	0	0	●
17	Height difference between indoor units (*1)	Standard	1	7	0	0	●
		Forbidden			0	1	
		Height difference			0	2	
		Prohibited			0	3	
		Prohibited			0	4	
If installing the indoor units (even only one set) to a lower floor than the outdoor unit, and the height difference between the indoor units is 3 m or greater (i.e., if installing the indoor units on separate floors), set "02 (height difference)".							
20	Switching between batch stop or emergency stop (*1)	Batch stop	2	0	0	0	●
		Emergency stop			0	1	
This mode selects the pattern of the stop function to be operated by the external input terminal (CN134).							
<ul style="list-style-type: none"> Batch stop: The stop of all indoor units connected to same refrigerant system due to input signal coming from CN134. Emergency stop: When emergency stop is actuated, the indoor unit does not accept the operation command from the remote controller. On the other hand, when the emergency stop is released (no input from CN134), the air conditioner does not return to the original operation until the indoor unit is turned on by the remote controller. 							
21	Operation mode selecting method (*1)	Priority given to the first command	2	1	0	0	●
		Priority given to external input of outdoor unit			0	1	
		Priority given to administrative indoor unit			0	2	
<ul style="list-style-type: none"> Select the priority setting of the operation mode. Priority given to the first command: Priority is given to the operation mode which is set first. Priority given to external input of outdoor unit: Priority is given to the operation mode which is set by the external input terminal (CN132). Priority given to administrative indoor unit: Priority is given to the operation mode of the administrative indoor unit which is set by the wired remote controller. 							
22	Snow falling protection fan mode (*1)	Enable	2	2	0	0	●
		Disable			0	1	
This mode operates the fans of outdoor units in order to prevent the units from stopping operation when they are covered by snow.							
23	Interval setting for snow falling protection fan mode (*1)	Standard (30 minutes)	2	3	0	0	●
		Short 1 (5 minutes)			0	1	
		Short 2 (10 minutes)			0	2	
		Short 3 (20 minutes)			0	3	
When the snow falling protection fan mode is set, the operation interval of the fans of outdoor units can be selected.							
24	High static pressure mode	Standard	2	4	0	0	●
		High static pressure 1 (equivalent to 30 Pa)			0	1	
		High static pressure 2 (equivalent to 80 Pa)			0	2	
		Prohibited			0	3	
When installing a duct to the blow-off outlet of an outdoor unit, set the high static pressure mode according to the static pressure of the duct to be installed. Furthermore, use this setting if the air blow of an outdoor unit is poor, such as when installed in a place with a low ceiling.							
25	Prohibited (Factory default)		2	5	0	0	●
26	Prohibited (Factory default)		2	6	0	0	●
27	Prohibited (Factory default)		2	7	0	0	●
28	Prohibited (Factory default)		2	8	0	0	●
29	Prohibited (Factory default)		2	9	0	0	●
30	Energy saving level setting (*1)	Level 1 (stop)	3	0	0	0	●
		Level 2 (operated at 40% capacity)			0	1	
		Level 3 (operated at 60% capacity)			0	2	
		Level 4 (operated at 80% capacity)			0	3	
		Level 5 (operated at 100% capacity)			0	4	
The capacity limit can be selected by the external input terminal (CN133) when operating with the "Energy Saving Peak Cut function". The lower the level, the more the effect of energy saving, but the cooling/heating performance will also drop.							

32	Prohibited (Factory default)		3	2	0	0	●
33	Prohibited (Factory default)		3	3	0	0	●
40	Capacity priority setting (in low noise mode) (*1)	Off (quiet priority)	4	0	0	0	●
		On (capacity priority)			0	1	
		If the cooling/heating performance becomes insufficient when the low noise mode is set, it is possible to set "capacity priority" that automatically cancels the low noise mode (once performance is restored, the mode will automatically return to the low noise mode).					
41	Low noise mode setting (*1)	Off (Normal)	4	1	0	0	●
		On (Low noise mode)			0	1	
42	Low noise mode operation level setting	Level 1	4	2	0	0	●
		Level 2			0	1	
Level 1: The operating sound lowers from about 3 to 5 dB(A) more than the rated value Level 2: The operating sound lowers from about 3 to 5 dB(A) more than the Level 1							
53	Intelligent refrigerant control	Enable	5	3	0	0	●
		Disable			0	1	
		Enable only evaporation temperature control			0	2	
		Enable only condensation temperature control			0	3	
61	Prohibited (Factory default)		6	1	0	0	●
62	Prohibited (Factory default)		6	2	0	0	●
63	Prohibited (Factory default)		6	3	0	0	●
70	Electricity meter No. setting 1 (*2)	Setting number (x00)	7	0	0	0	●
		Setting number (x01)			0	1	
		
		Setting number (x98)			9	8	
		Setting number (x99)			9	9	
Set the ones digit and tens digit of the No. of the electricity meter connected to CN135.							
71	Electricity meter No. setting 2 (*2)	Setting number (0xx)	7	1	0	0	●
		Setting number (1xx)			0	1	
		Setting number (2xx)			0	2	
Set the hundreds digit of the No. of the electricity meter connected to CN135.							
72	Electricity meter pulse setting 1 (*3)	Setting number (xx00)	7	2	0	0	●
		Setting number (xx01)			0	1	
		
		Setting number (xx98)			9	8	
		Setting number (xx99)			9	9	
Set the ones digit and tens digit of the No. of the electricity meter pulse setting connected to CN135.							
73	Electricity meter pulse setting 2 (*3)	Setting number (00xx)	7	3	0	0	●
		Setting number (01xx)			0	1	
		
		Setting number (98xx)			9	8	
		Setting number (99xx)			9	9	
Set the hundreds digit and thousands digit of the electricity meter pulse setting connected to CN135.							

*1: Do not set this for outdoor units with subordinate setting.

*2: When electricity meter No. is set to "000" and "201 to 299", the pulses input to CN135 become ineffective. Available setting number is "001" to "200"

*3: When the electricity meter pulse setting is set to "0000", the pulses input to CN135 become ineffective. Available setting number is "0001" to "9999"

(1) Turn on the power of the outdoor unit and enter standby mode.

When system is normal

POWER/MODE lamp lights up. (ERROR lamp is off.)

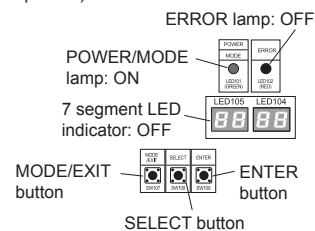

When system is abnormal

Check the settings as there is an error in the settings for outdoor unit address (DIP switch SET3-1, 2) or number of connected subordinate units (DIP switch SET3-3, 4).

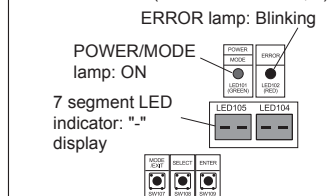

(2) Setting method

Use the "MODE/EXIT", "SELECT", and "ENTER" buttons to configure settings according to the procedures below.
(If no setting is made, the factory default setting will be displayed.)

- MODE/EXIT** : Press the "MODE/EXIT" button
- SELECT** : Press the "SELECT" button
- ENTER** : Press the "ENTER" button.
- ENTER** (with diagonal lines) : Press the "ENTER" button for more than 3 seconds.

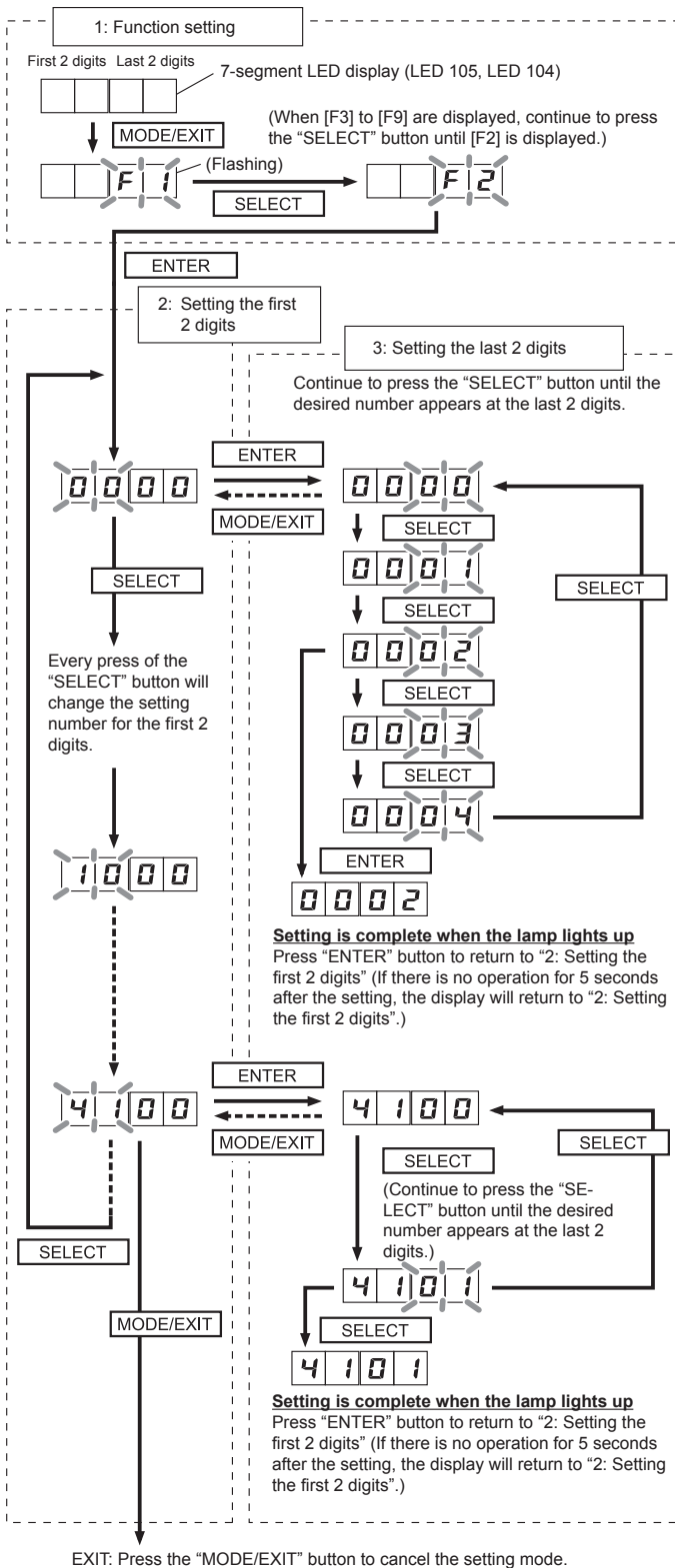

7.5. Address setting for signal amplifiers

7.5.1 Address setting for signal amplifiers

When using signal amplifiers, the address for signal amplifiers must be set. The address for signal amplifiers can be set automatically from 1 outdoor unit (primary unit) on the network.
Refer to "Fig. Wiring example for automatic address setting" (7.6.1 chapter) for the wiring example.
(For manual setting of address, refer to the signal amplifier installation manual.)

7.5.2 Automatic address setting for signal amplifiers

When setting the address of the signal amplifier, please use the factory setting. (See the installation manual of the signal amplifier)
• When the system is normal, nothing will be displayed on the 7-segment display.
• When ERROR is displayed, inspect the units.
Use the "MODE/EXIT", "SELECT", and "ENTER" buttons on the outdoor unit PC board to configure settings according to the procedures below.

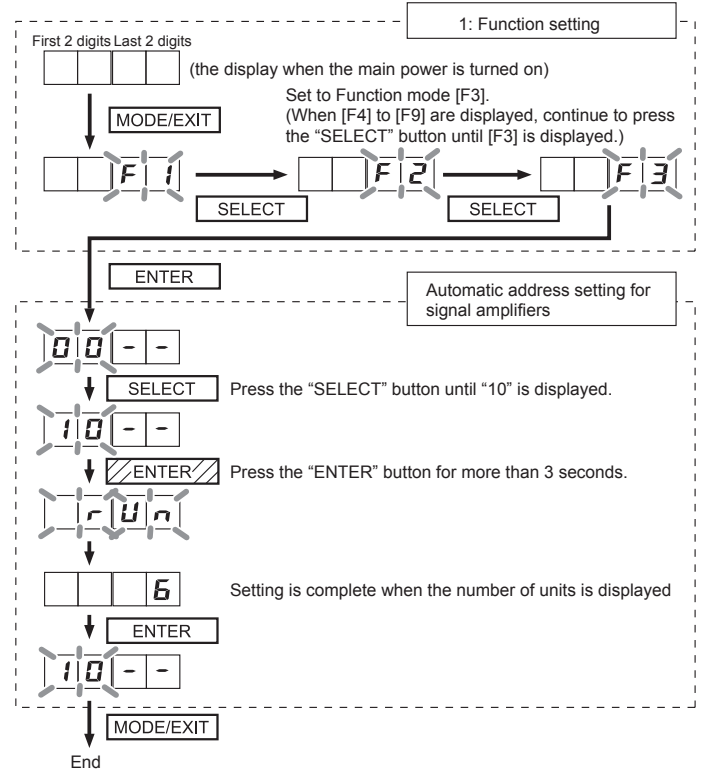

7.6. Indoor unit address setting

7.6.1 Indoor unit address setting

Address must be set for the indoor unit.
Manual setting → • When setting with the switch inside the indoor unit, refer to the indoor unit operating manual.
• When setting with a remote control, refer to the remote control operating manual.
Automatic setting → • Check that the wiring is as shown in the figure below. Operate using the outdoor primary unit of each refrigerant system.

Wiring example for automatic address setting

(1): Signal amplifier wiring example
(2)(3): Indoor unit wiring example
(Connect the indoor and outdoor units of the same refrigerant system as shown below.)

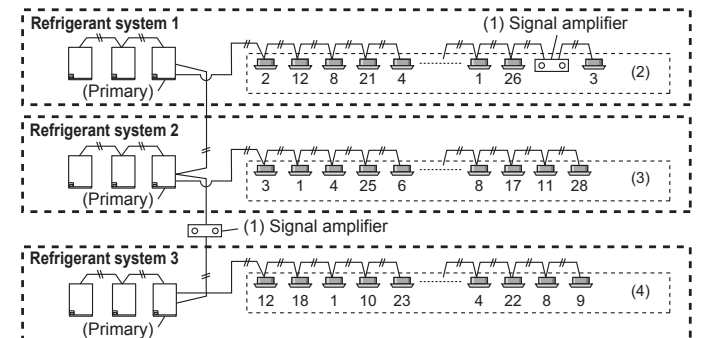

- NOTES:**
- When network is connected to other refrigerant systems, the automatic address function cannot be used.
 - The addresses of indoor units that have been configured automatically cannot be assigned in the order when they are installed. (Refer to the indoor unit installation manual for the procedures to check the addresses.)

7.6.2 Procedures to enable automatic address setting on indoor units

Check that the rotary switch IU AD on the indoor unit PC board is set to "00". If it is not set to "00", it means the address of that device is not set. (Factory default is "00"). Turn on the power of the indoor and outdoor units.

- When the system is normal, nothing will be displayed on the 7-segment display.
- When ERROR is displayed, inspect the units.

Use the "MODE/EXIT", "SELECT", and "ENTER" buttons on the outdoor unit PC board to configure settings according to the procedures below.

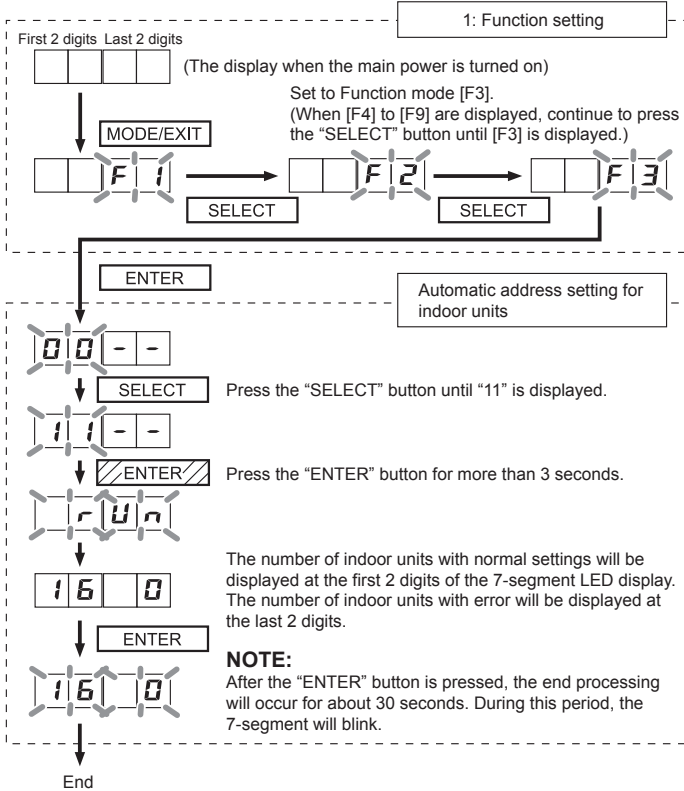

7.7. Resistance measurement of transmission cable (Measure with breaker OFF)

CAUTION

Do not turn on the power if the resistance between the terminals of the transmission cable is abnormal. Otherwise, the PC board may be damaged.

Measure the resistance between 2 terminals of a transmission cable.

(1) Transmission cable connecting indoor units, outdoor units, and signal amplifiers

Measure the resistance of the signal amplifier terminal and the terminal of the indoor and outdoor units connected farthest away from the device where terminal resistor is measured. A value from the table is displayed, depending on the distance from the signal amplifier and the device where the terminal resistor is set. This value is an estimate.

(2) Transmission cable connecting outdoor units in a refrigerant system

The resistance between the terminals of the transmission cable is 45-60 Ω. This value is an estimate.

Approximate resistance (Ω)	Distance from termination resistor (m)				
	0-100	~200	~300	~400	~500
0 ~ 50	A short circuit somewhere or 2 or more termination resistors are connected				
50					
60					
70					
80					
90					
100					
110					
120					
130					
140					
150					
160					
170					
180					
190 ~	Faulty contact or wiring length over 500 m				
1K ~ ∞	Faulty contact, open circuit, or no termination resistor				

8. PIPE INSTALLATION II

Fig. A Connection system

In case of connected 1 outdoor unit

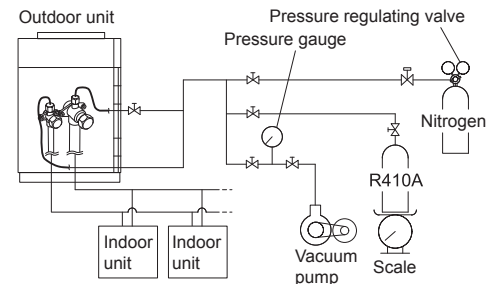

In case of connected many outdoor units

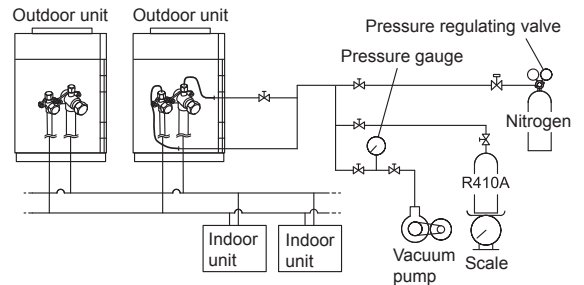

Fig. B

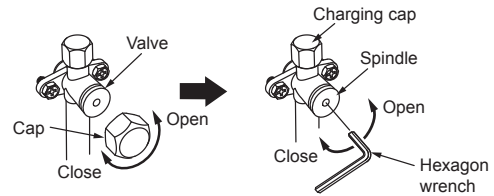

Table. A

Valve type	Spindle	Cap	Charging cap
Liquid	9.0 to 12.0 N·m (90 to 120 kgf·cm)	20.0 to 24.0 N·m (200 to 240 kgf·cm)	12.5 to 16.0 N·m (125 to 160 kgf·cm)
Suction gas	27.0 to 33.0 N·m	25.0 to 30.0 N·m	12.5 to 16.0 N·m
Discharge gas	(270 to 330 kgf·cm)	(250 to 300 kgf·cm)	(125 to 160 kgf·cm)

8.1. Sealing test

CAUTION

Use only nitrogen gas. Never use refrigerant gas, oxygen, in flammable gas or poisonous gas to pressurize the system. (If oxygen is used, there is the danger of an explosion.)

Do not apply shock during sealing test. It can rupture the pipes and cause serious injury.

Do not turn on the power unless all operations are complete.

Do not block the walls and the ceiling until the sealing test and the charging of the refrigerant gas have been completed.

After connecting the pipes, perform a sealing test. Recheck that the 3-way valve are closed before performing a sealing test. (Fig. B) Pour nitrogen gas through both the liquid pipe and the gas pipe. Pressurize nitrogen gas to 4.2 MPa to perform the sealing test.

Check all flare connection areas and brazed areas.

Then, check that the pressure has not decreased.

Compare the pressures after pressurizing and letting it stand for 24 hours, and check that the pressure has not decreased.

* When the outdoor temperature changes 5 °C, the test pressure changes 0.05 MPa. If the pressure has dropped, the pipe joints may be leaking.

If a leakage is found, immediately repair it and perform a sealing test again.

* Decrease the pressure of nitrogen gas before blazing

After completing the sealing test, release the nitrogen gas from both valves. Release the nitrogen gas slowly.

8.2. Vacuum process

CAUTION

Do not turn on the power unless all operations are complete.

If the system is not evacuated sufficiently, its performance will drop.

Be sure to evacuate the refrigerant system using a vacuum pump.

The refrigerant pressure may sometimes not rise when a closed valve is opened after the system is evacuated using a vacuum pump. This is caused by the closure of the refrigerant system of the outdoor unit by the electronic expansion valve. This will not affect the operation of the unit.

Use a clean gauge manifold and charging hose that were designed specifically for use with R410A. Using the same vacuum equipment for different refrigerants may damage the vacuum pump or the unit.

Do not purge the air with refrigerants, but use a vacuum pump to evacuate the system.

- If moisture might enter the piping, follow below. (i.e., if doing work during the rainy season, if the actual work takes long enough that condensation may form on the inside of the pipes, if rain might enter the pipes during work, etc.)
- After operating the vacuum pump for 2 hours, pressurize to 0.05 MPa (i.e., vacuum breakdown) with nitrogen gas, then depressurize down to -100.7 kPa (-755 mmHg) for an hour using the vacuum pump (vacuum process).
- If the pressure does not reach -100.7 kPa (-755 mmHg) even after depressurizing for at least 2 hours, repeat the vacuum breakdown - vacuum process.

After vacuum process, maintain the vacuum for an hour and make sure the pressure does not rise by monitoring with a vacuum gauge.

8.2.1 Evacuation procedure

- (1) Remove the caps of the gas pipe and liquid pipe and check that the valves are closed.
- (2) Remove the charging cap.
- (3) Connect a vacuum pump and a pressure gauge to a charging hose and connect it to the charging port.
- (4) Activate the vacuum pump and vacuum the indoor unit and connection piping until the pressure gauge becomes -100.7kPa (-755mmHg). Evacuate from both the gas pipe and the liquid pipe.
- (5) Continue evacuating the system for 1 hour after the pressure gauge reads -100.7kPa (-755mmHg).
- (6) Remove the charging hose and reinstall the charging cap.

CAUTION

Do not turn on the power unless all operations are complete.

After evacuating the system, add refrigerant.

Do not charge the system with a refrigerant other than R410A.

Always keep to the limit on the total amount of refrigerant. Exceeding the limit on the total amount of refrigerant will lead to malfunction during charging of refrigerant.

Do not reuse recovered refrigerant.

Use an electronic scale to measure the charging amount of refrigerant. Adding more refrigerant than the specified amount will cause a malfunction.

Charge refrigerant using the liquid pipe. Adding refrigerant through the gas pipe will cause a malfunction.

Add refrigerant by charging the system with the refrigerant in the liquid state. If the refrigerant cylinder is equipped with a siphon, it is not necessary to place the cylinder upright.

Check if the steel cylinder has a siphon installed or not before filling. (There is an indication "with siphon for filling liquid" on the steel cylinder.)

Filling method for cylinder with siphon

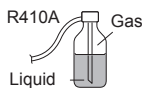

Set the cylinder vertical and fill with the liquid. (Liquid can be filled without turning bottom up with the siphon inside.)

Filling method for other cylinders

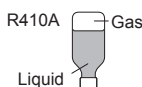

Turn bottom up and fill with liquid. (Be careful to avoid turning over the cylinder.)

Be sure to use the special tools for R410A for pressure resistance and to avoid mixing of impure substances.

If the units are further apart than the maximum pipe length, correct operation cannot be guaranteed.

Make sure to back closing valve after refrigerant charging. Otherwise, the compressor may fail.

Minimize refrigerant release to the air. Excessive release is prohibited under the Freon Collection and Destruction Law.

8.2.2 Procedure for charging the system with refrigerant

- (1) Remove the charging cap from the liquid pipe. Use standard refrigeration practices when charging refrigerant.
- (2) Attach a charging hose to the refrigerant cylinder, and connect it to the charging port.
- (3) Add refrigerant by calculating the additional refrigerant volume in accordance with the calculation formula indicated below.
- (4) Remove the charging cap and install the charging hose.
- (5) Remove the body caps (suction gas pipe, discharge gas pipe and liquid pipe), and open the valves.
- (6) Close the body caps.
- (7) After adding refrigerant, indicate the added charging volume on the unit.

NOTES:

- Tighten the body caps and charging caps to the torque values specified in the Table A. To open and close the valves, Use an M4 hexagon wrench for liquid pipe. Use an M8 hexagon wrench for suction gas pipe and discharge gas pipe.
- If you cannot charge the specified amount of refrigerant with the above method, be sure to charge the refrigerant through the gas pipe while operating in cooling mode. In order to prevent liquid back-flow, carefully operate the refrigerant cylinder valve so that the refrigerant will flow in certain part at a time.

8.2.3 Checking total amount of refrigerant and calculating the amount of refrigerant charge to be added

- The amount of refrigerant charge to be added is the total value of the basic refrigerant charge amount and the value calculated from the length of the liquid pipe.
- Round up the value to 2 decimal places.

Model	HP	d Factory charged amount (kg)	a Additional amount for outdoor unit (kg)
AJ*072LALDH	8	11.70	0
AJ*090LALDH	10	11.70	0
AJ*108LALDH	12	11.80	3.30
AJ*126LALDH	14	11.80	3.30
AJ*144LALDH	16	11.80	3.30

Diameter of liquid pipe (mm)	b Additional amount for pipe length (kg/m)
Ø6.35	0.021
Ø9.52	0.058
Ø12.70	0.114
Ø15.88	0.178
Ø19.05	0.268

- (1) Calculation of additional amount for pipe length.

$$A = \begin{array}{|c|} \hline \text{Outdoor unit 1 additional amount for outdoor unit} \\ \hline \text{kg} \\ \hline \end{array} + \begin{array}{|c|} \hline \text{Outdoor unit 2 additional amount for outdoor unit} \\ \hline \text{kg} \\ \hline \end{array} + \begin{array}{|c|} \hline \text{Outdoor unit 3 additional amount for outdoor unit} \\ \hline \text{kg} \\ \hline \end{array}$$

$$= \begin{array}{|c|} \hline \text{Total} \\ \hline \text{kg} \\ \hline \end{array}$$

- (2) Calculation of additional amount for pipe length.

$$B = \begin{array}{|c|} \hline \begin{array}{|c|} \hline \text{Total length of } \phi 19.05 \text{ mm liquid pipe} \\ \hline m \\ \hline \end{array} \times \begin{array}{|c|} \hline b \\ \hline 0.268 \text{ (kg/m)} \\ \hline \end{array} \\ \hline \text{kg} \\ \hline \end{array} + \begin{array}{|c|} \hline \begin{array}{|c|} \hline \text{Total length of } \phi 15.88 \text{ mm liquid pipe} \\ \hline m \\ \hline \end{array} \times \begin{array}{|c|} \hline b \\ \hline 0.178 \text{ (kg/m)} \\ \hline \end{array} \\ \hline \text{kg} \\ \hline \end{array} + \begin{array}{|c|} \hline \begin{array}{|c|} \hline \text{Total length of } \phi 12.70 \text{ mm liquid pipe} \\ \hline m \\ \hline \end{array} \times \begin{array}{|c|} \hline b \\ \hline 0.114 \text{ (kg/m)} \\ \hline \end{array} \\ \hline \text{kg} \\ \hline \end{array}$$

$$+ \begin{array}{|c|} \hline \begin{array}{|c|} \hline \text{Total length of } \phi 9.52 \text{ mm liquid pipe} \\ \hline m \\ \hline \end{array} \times \begin{array}{|c|} \hline b \\ \hline 0.058 \text{ (kg/m)} \\ \hline \end{array} \\ \hline \text{kg} \\ \hline \end{array} = \begin{array}{|c|} \hline \begin{array}{|c|} \hline \text{Total length of } \phi 6.35 \text{ mm liquid pipe} \\ \hline m \\ \hline \end{array} \times \begin{array}{|c|} \hline b \\ \hline 0.021 \text{ (kg/m)} \\ \hline \end{array} \\ \hline \text{kg} \\ \hline \end{array} + \begin{array}{|c|} \hline \text{Total} \\ \hline \text{kg} \\ \hline \end{array}$$

- (3) Calculation of additional charge refrigerant.

$$C = A + B = \begin{array}{|c|} \hline \text{kg} \\ \hline \end{array} \quad (\text{Round up C to 2 decimal place})$$

- (4) Calculation of factory charged amount.

$$A = \begin{array}{|c|} \hline \text{Outdoor unit 1 factory charged amount} \\ \hline \text{kg} \\ \hline \end{array} + \begin{array}{|c|} \hline \text{Outdoor unit 2 factory charged amount} \\ \hline \text{kg} \\ \hline \end{array} + \begin{array}{|c|} \hline \text{Outdoor unit 3 factory charged amount} \\ \hline \text{kg} \\ \hline \end{array}$$

$$= \begin{array}{|c|} \hline \text{Total} \\ \hline \text{kg} \\ \hline \end{array}$$

- (5) Total refrigerant amount check.

$$E = C + D = \begin{array}{|c|} \hline \text{kg} \\ \hline \end{array}$$

Check the total refrigerant amount under the following conditions.

Condition	Computational formula
For 1 outdoor unit per refrigerant system: Total amount of refrigerant \leq 31.5 kg	$E \leq 31.5 \text{ kg}$
For 2 outdoor units per refrigerant system: Total amount of refrigerant \leq 63 kg	$E \leq 63 \text{ kg}$
For 3 outdoor units per refrigerant system: Total amount of refrigerant \leq 94.5 kg	$E \leq 94.5 \text{ kg}$

<Calculation>

When there are 3 outdoor units (AJ*144LALDH, AJ*126LALDH, AJ*108LALDH) connected to 1 system.

- Calculation of additional amount for outdoor unit.
 $A = 3.30 \text{ (kg)} + 3.30 \text{ (kg)} + 3.30 \text{ (kg)} = 9.90 \text{ (kg)}$
- Calculation of additional amount for pipe length.
 If liquid pipe piping length is the following.
 $\phi 19.05: 50 \text{ m}, \phi 15.88: 25 \text{ m}, \phi 12.70: 0 \text{ m}, \phi 9.52: 20 \text{ m}, \phi 6.53: 15 \text{ m}$
 Additional charge volume
 $B = 50 \text{ (m)} \times 0.268 \text{ (kg/m)} + 25 \text{ (m)} \times 0.178 \text{ (kg/m)}$
 $+ 0 \text{ (m)} \times 0.114 \text{ (kg/m)} + 20 \text{ (m)} \times 0.058 \text{ (kg/m)}$
 $+ 15 \text{ (m)} \times 0.021 \text{ (kg/m)}$
 $= 19.325 \text{ kg}$
- Calculation of additional charge refrigerant
 $C = A + B = 9.90 \text{ (kg)} + 19.33 \text{ (kg)} = 29.23 \text{ (kg)}$
- Calculation of factory charged amount
 $D = 11.8 \text{ (kg)} + 11.8 \text{ (kg)} + 11.8 \text{ (kg)} = 35.4 \text{ (kg)}$
- Check the total amount of refrigerant
 When 3 outdoor units are connected to 1 system, the following condition must be satisfied.
 Condition: $E = C + D \leq 94.5 \text{ (kg)}$
 Calculation: $29.23 \text{ (kg)} + 35.4 \text{ (kg)} = 64.63 \text{ (kg)} < 94.5 \text{ (kg)}$
 → No problem if the above condition is satisfied.

8.3. Installing insulation

- Install insulation material after conducting the "8.1 Sealing test".
- To prevent condensation and water droplets, install insulation material on the refrigerant pipe.
- Refer to the table to determine the thickness of the insulation material.
- If the outdoor unit is installed at a level that is higher than the indoor unit, the water that has condensed in the 3-way valve of the outdoor unit could travel to the indoor unit.
 Therefore, use putty in the space between the pipe and the insulation to prevent the entry of water.

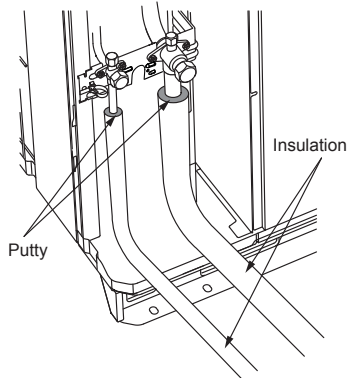

Table. Selection of insulation
 (Use an insulation material with equal heat transmission rate or below 0.040 W/(m·k))

Relative humidity		Insulation material minimum thickness (mm)			
		≤ 70%	≤ 75%	≤ 80%	≤ 85%
Pipe diameter (mm)	6.35	8	10	13	17
	9.52	9	11	14	18
	12.70	10	12	15	19
	15.88	10	12	16	20
	19.05	10	13	16	21
	22.22	11	13	17	22
	28.58	11	14	18	23
	34.92	11	14	18	24
41.27	12	15	19	25	

* When the ambient temperature and relative humidity exceed 32°C (DB) and 85% respectively, please strengthen heat insulation of refrigerant pipe.

9. TEST RUN

9.1. Pre-check for test run

Before the test operation, check the following items.

- Is there a gas leakage? (At pipe connections {flange connections and brazed areas})
- Is the system charged with the specified volume of refrigerant?
- Is the refrigerant circuit address correct?
- Is a breaker installed at the power supply cable of outdoor unit?
- Are the cable connected to the terminals without looseness, and in accordance with the specifications?
- Are the initial settings of the switches of the outdoor unit correctly configured?
- Is the 3-way valve of the outdoor unit open? (Gas pipe and liquid pipe)
- Is power supplied to the crank case heater for more than 12 hours? Electricity current in short period of time may result in compressor damage.
- Are all the indoor units within the same coolant system connected to the power? Operating indoor units which are not connected to the power may result in malfunctions.
- Is Indoor unit connection check performed? Test run doesn't operate if Indoor unit connection check is not performed.



After checking that the above items are all in order, refer to "9.2. Test run method" to test operation the unit.
 If there are problems, adjust immediately and recheck.

9.2. Test run method

Be sure to configure test run settings only when the outdoor unit has stopped operating.

- Depending on the communication status between the indoor and outdoor units, it may take several minutes for the system to start operating after settings for the test run are complete.
- After the test run settings are complete, the outdoor unit and the connected indoor units will start operating. Room temperature control will not activate during test operation (continuous operation).
- If a knocking sound can be heard in the liquid compression of the compressor, stop the unit immediately and then energize the crank case heater for a sufficient length of time before restarting the operation.

Perform test operation for each refrigerant system.

You can set "cooling test operation" or "heating test operation" with the push button on the outdoor unit PC board.

Test operation setting method

Use the "MODE/EXIT", "SELECT", and "ENTER" buttons on the indoor unit PC board to configure settings according to the procedures below.

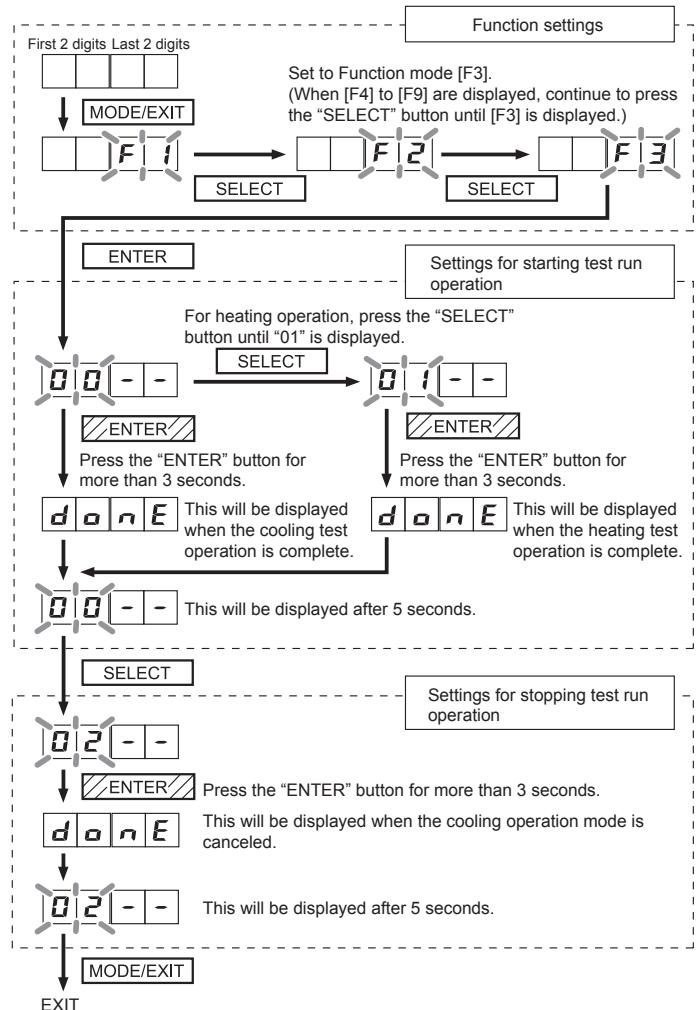

After the test operation is complete, turn off the power. Attach the cover of the electrical component box and the front panel of the outdoor unit.

NOTES:

- Check that the indoor and outdoor units connected to the same refrigerant system are operating normally.
- When indoor or outdoor units are not operating, or when the indoor and outdoor units of other refrigerant systems are operating, the indoor/outdoor unit address are not configured correctly.
- The system will not operate normally with an incorrect DIP switch setting. Stop the system immediately and recheck the DIP switch setting.

9.3. Checklist

Check description	Check method	Criteria
(1) High and low pressure values are normal.	Check it with a pressure gauge.	Cooling: low pressure approx. 0.8 MPa Heating: high pressure approx. 3.0 MPa
(2) Drain water is discharged smoothly through the drain hose.	Check it by pouring water.	—
(3) Indoor and outdoor unit fans are operating.	Check them visually.	—
(4) Compressor operates after the indoor unit operates.	Check the operating sound.	—
(5) Difference between inlet and outlet temperatures is normal.	Measure the inlet and outlet temperatures.	Temperature difference 10 degrees
(6) Error is not displayed.	Check the 7-segment display.	Error blinking or no error code display

10. LED STATUS

You can determine the operating status by the lighting up and blinking of the LED display. Check the status using the table below.

10.1. Normal operation codes

Mode	CODE	DESCRIPTION
Operation	C L	Cooling
	H t	Heating
	o r	During oil recovery operation
	d F	During defrosting operation
	P C	During power saving operation
	L n	During low noise operation
	S n	During setting of snowfall mode

10.2. Error codes

Mode	Code	Description
Communication error	E 1 3. 1	Communication error between outdoor units
	E 1 4. 1	Outdoor unit network communication 1 error
	E 1 4. 2	Outdoor unit network communication 2 error
	E 1 4. 5	The number of indoor unit shortage
Function setting error	E 2 8. 1	Auto address setting error
	E 2 8. 4	Signal amplifier auto address error
Indoor unit actuator error	E 5 U. 1	Indoor unit miscellaneous error
Outdoor unit PCB/ electrical component/ switch error	E 6 1. 5	Outdoor unit reverse phase, missing phase wire error
	E 6 2. 3	Outdoor unit EEPROM access error
	E 6 2. 6	Outdoor unit inverters communication error
	E 6 2. 8	Outdoor unit EEPROM data corruption error
	E 6 3. 1	Outdoor unit inverter error
	E 6 7. 2	Outdoor unit inverter PCB power short interruption error
	E 6 8. 2	Outdoor unit rush current limiting resistor temp. rise error (protective operation)
	E 6 9. 1	Outdoor unit transmission PCB parallel communication error
Outdoor unit sensor error	E 7 1. 1	Outdoor unit discharge thermistor 1 error
	E 7 2. 1	Outdoor unit compressor temp. sensor 1 error
	E 7 3. 4	Outdoor unit heat ex. 1 gas temp. sensor error
	E 7 3. 5	Outdoor unit heat ex. 1 liquid temp. sensor error
	E 7 3. 6	Outdoor unit heat ex. 2 gas temp. sensor error
	E 7 3. 7	Outdoor unit heat ex. 2 liquid temp. sensor error
	E 7 4. 1	Outside air thermistor error
	E 7 5. 1	Outdoor unit suction gas thermistor error
	E 7 7. 1	Outdoor unit heat sink thermistor error
	E 8 2. 2	Outdoor unit sub-cool heat ex. gas outlet thermistor error
	E 8 3. 1	Outdoor unit liquid pipe thermistor 1 error
	E 8 3. 2	Outdoor unit liquid pipe thermistor 2 error
	E 8 4. 1	Outdoor unit current sensor 1 error (permanent stop)
	E 8 6. 1	Outdoor unit discharge pressure sensor error
	E 8 6. 3	Outdoor unit suction pressure sensor error
	E 8 6. 4	Outdoor unit high pressure switch 1 error

Mode	Code	Description
Outdoor unit actuator error	E 9 3. 1	Outdoor unit inverter compressor start up error
	E 9 4. 1	Outdoor unit trip detection
	E 9 5. 5	Outdoor unit compressor motor loss of synchronization
	E 9 7. 1	Outdoor unit fan motor lock error
	E 9 7. 5	Outdoor unit fan motor temperature error (protective action)
	E 9 7. 9	Outdoor unit fan motor driver error
	E 9 A. 1	Outdoor unit coil 1 (expansion valve 1) error
	E 9 A. 2	Outdoor unit coil 2 (expansion valve 2) error
Refrigerant system error	E 9 A. 3	Outdoor unit coil 3 (expansion valve 3) error
	E 9 U. 2	Outdoor subordinate unit error
	E A 1. 1	Outdoor unit discharge temperature 1 error
	E A 3. 1	Outdoor unit compressor 1 temperature error
	E A 4. 1	Outdoor unit high pressure error
	E A 4. 2	Outdoor unit high pressure protection 1
	E A 5. 1	Outdoor unit low pressure error
	E A 6. 3	Outdoor heat exchanger 1 gas temperature error
	E A 6. 4	Outdoor heat exchanger 2 gas temperature error
	E A C. 4	Outdoor unit heat sink temperature error

7 segment LED indicator:

A: R C: C: E: F: F: H: J: J: L: L: S: P: P: U: U: d: d: n: o: o: r: t: t:
1: 1: 2: 3: 3: 4: 5: 5: 6: 6: 7: 7: 8: 9: 9: 0: 0

11. INFORMATION

Main contents of label

Item	Detail
(1) Model name	Model name
(2) Serial number	Serial number
(3) Electric characteristics	Phase, rated voltage, and frequency
(4) Weight	Product weight
(5) Capacity	Cooling/heating capacity under cooling/heating condition (refer to item 15)
(6) Current	Electric current during cooling/heating operation under cooling/heating condition (refer to item 15)
(7) Input power	Input during cooling/heating operation under cooling/heating condition (refer to item 15)
(8) Max. Current	Maximum electric current (Test condition: IEC60335-2-40)
(9) Air circulation	Air circulation
(10) Noise level	Noise level
(11) Refrigerant	Refrigerant type and initial charging amount
(12) Max. pressure (HP/LP)	Means pressure of High Pressure side/Low Pressure side
(13) Protection	Protection level against dust and water
(14) Working temperature	Working temperature
(15) Condition of cooling/heating	Dry-bulb temperature and wet-bulb temperature under standard cooling/heating condition
(16) Condition of max. cooling	Dry-bulb temperature and wet-bulb temperature at maximum electric current and input
(17) Manufacture year	Manufacture year
(18) Origin	Origin country
(19) Manufacturer	Manufacturer FUJITSU GENERAL LIMITED Address: 3-3-17, Suenaga, Takatsu-ku, Kawasaki 213-8502, Japan

