

4. Refrigerant circuit

4-1. Models: AOYG36KRTA, AOYG45KRTA, and AOYG54KRTA

OUTDOOR UNIT
AOYG36-54KRTA

OUTDOOR UNIT
AOYG36-54KRTA

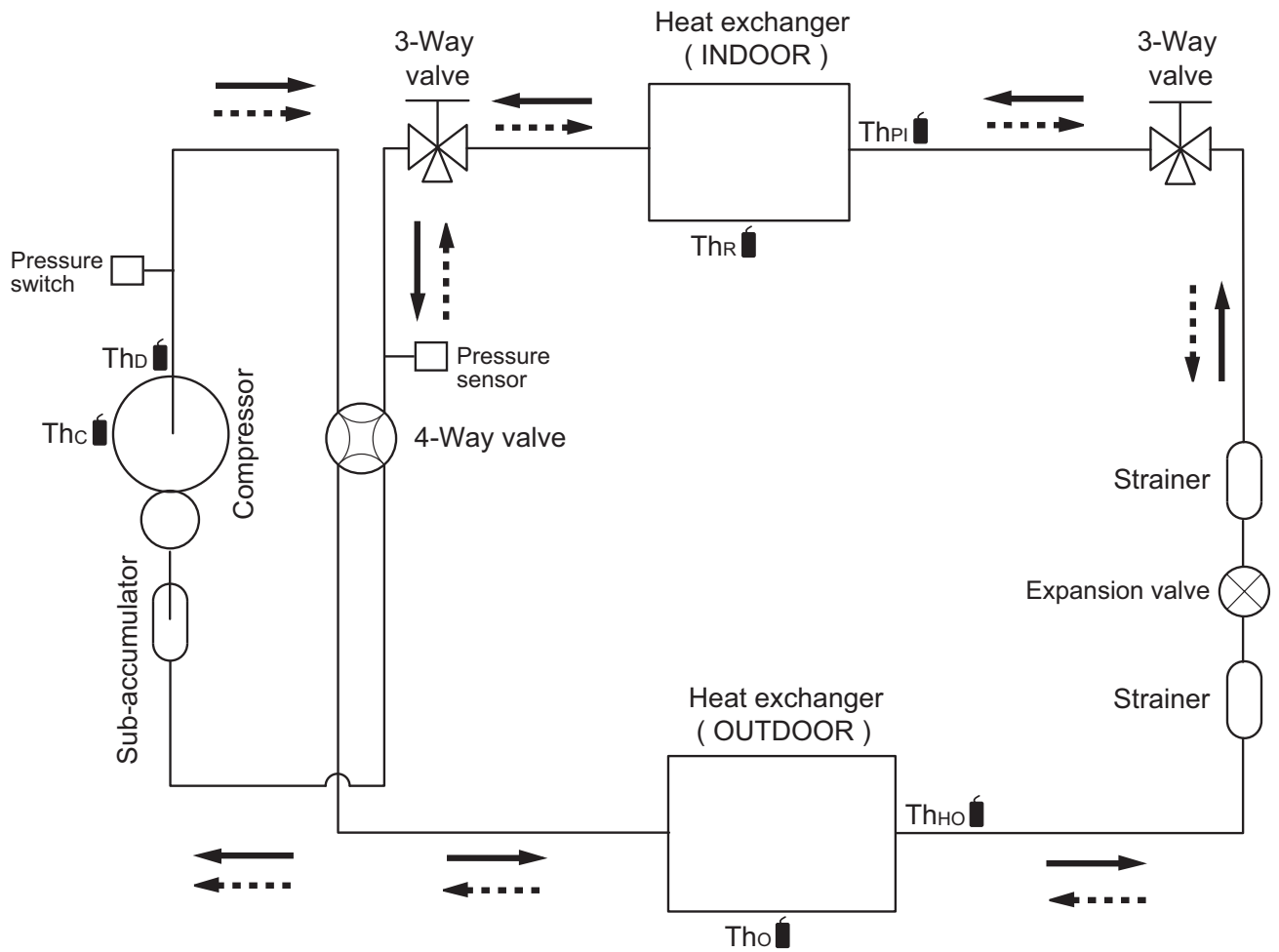

—→ : Cooling
 - - - -> : Heating

- Th_c : Thermistor (Compressor temperature)
- Th_D : Thermistor (Discharge temperature)
- Th_o : Thermistor (Outdoor temperature)
- Th_{HO} : Thermistor (Heat Exchanger Out temperature)
- Th_R : Thermistor (Room temperature)
- Th_{PI} : Thermistor (Pipe temperature)