

## 2. DIMENSIONS

### 2-1. DIMENSIONS

■ MODEL: AO\*G36LA, AO\*G45LA, AO\*G54LA

(Unit : mm)

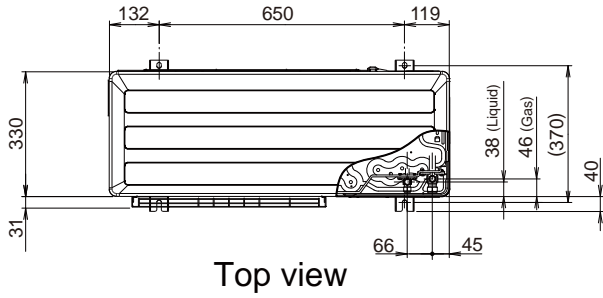

Top view

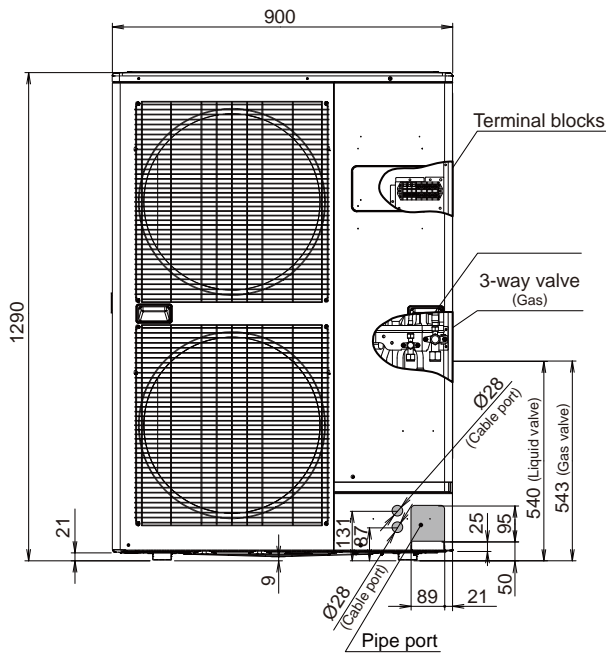

Front view

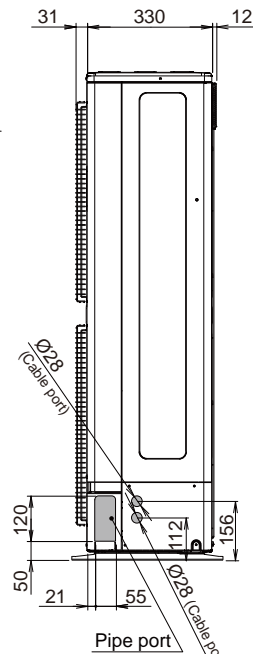

Side view

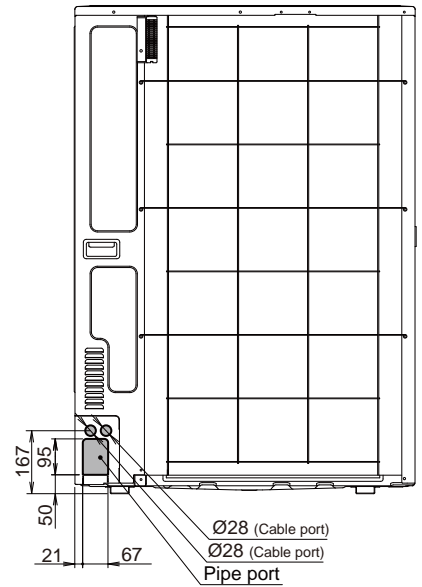

Rear view

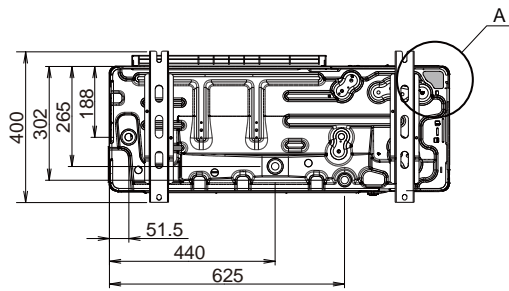

Bottom view

#### Detail A

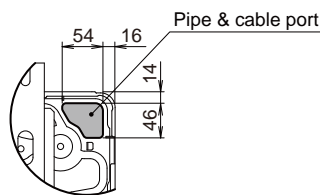

OUTDOOR UNIT

OUTDOOR UNIT

## 2-2. INSTALLATION PLACE

### 2-2-1. SINGLE OUTDOOR UNIT INSTALLATION

#### ■ WHEN THE UPWARD AREA IS OPEN

(Unit : mm)

Obstacles at rear only

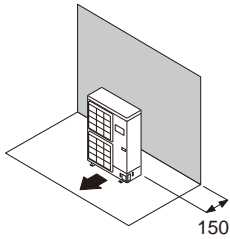

Obstacles at rear and sides only

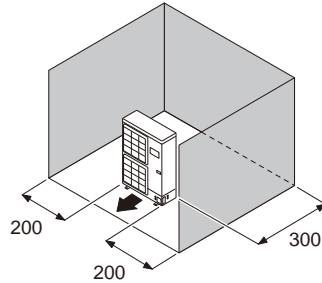

Obstacles at front only

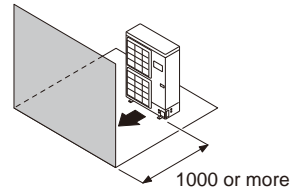

Obstacles at front and rear only

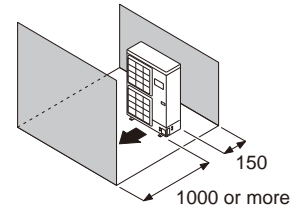

#### ■ WHEN AN OBSTRUCTION IS PRESENT ALSO IN THE UPWARD AREA

Obstacles at rear and above only

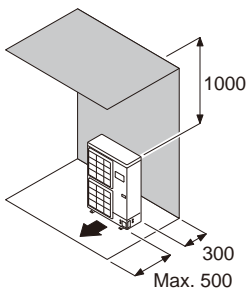

Obstacles at rear, sides, and above only

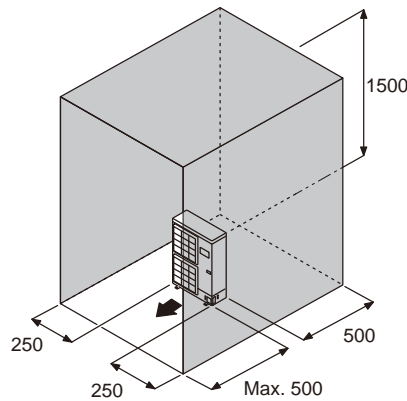

OUTDOOR UNIT

OUTDOOR UNIT

## 2-2-2. MULTIPLE OUTDOOR UNIT INSTALLATION

### ■ WHEN THE UPWARD AREA IS OPEN

(Unit : mm)

Obstacles at rear only

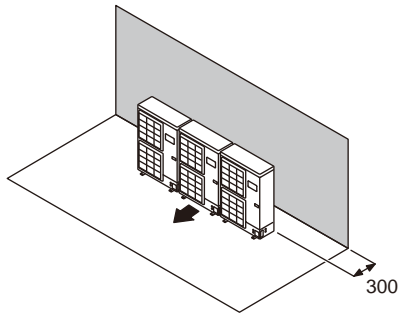

Obstacles at front only

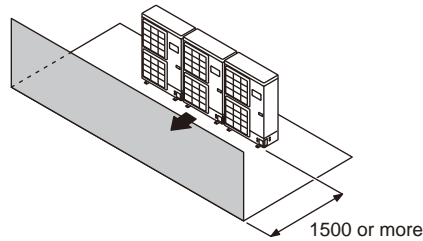

Obstacles at front and rear only

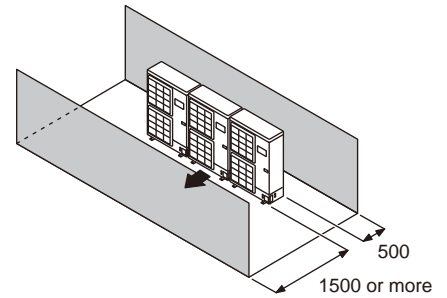

### ■ WHEN AN OBSTRUCTION IS PRESENT ALSO IN THE UPWARD AREA

(Unit : mm)

Obstacles at rear and above only

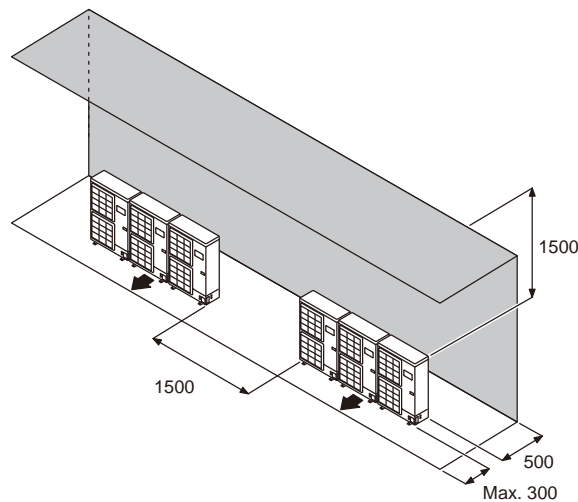

## 2-2-3. OUTDOOR UNIT INSTALLATION IN MULTI ROW

(Unit : mm)

Single parallel unit arrangement

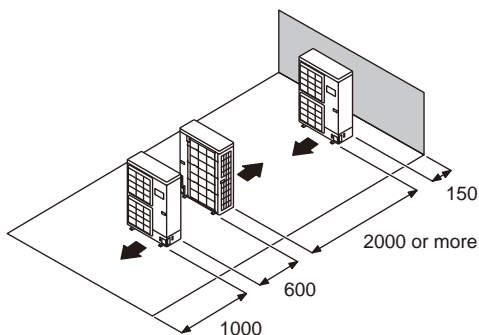

Multiple parallel unit arrangement

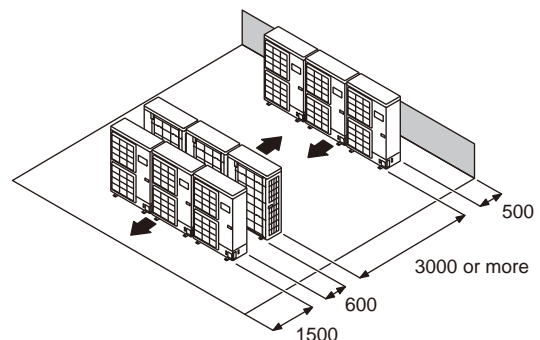

OUTDOOR UNIT

OUTDOOR UNIT