

13. Function settings

Perform appropriate function setting locally according to the installation environment.

NOTE: Incorrect settings can cause a product malfunction.

⚠ CAUTION

- Before setting up the switch buttons, discharge the static electricity from your body.
- Never touch the terminals or the patterns on the parts that are mounted on the PCB.

13-1. Local setting switch buttons

■ Control PCB and switch buttons location

Control PCB of the outdoor unit is located as shown in the following figure.

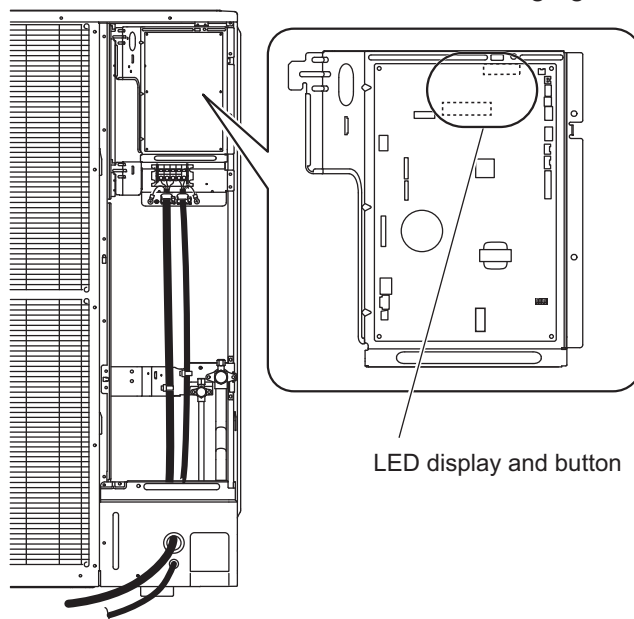

■ Switch buttons and the functions

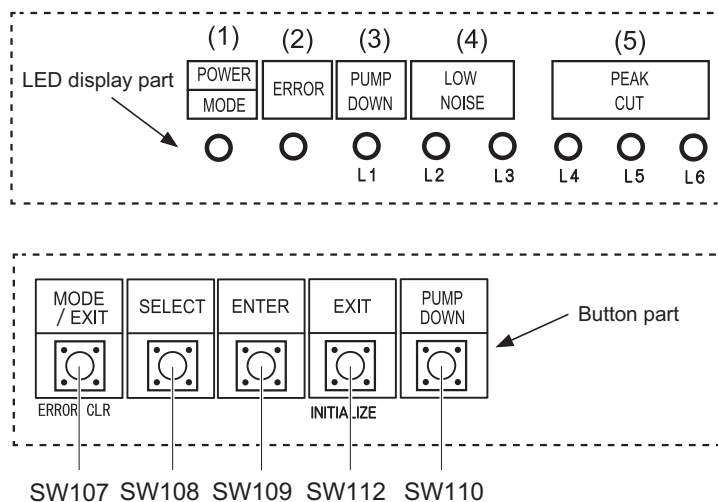

LED lamp			Function or operation method
(1)	POWER/MODE	Green	Lights on while power on. Local setting in outdoor unit or error code is displayed with blink.
(2)	ERROR	Red	Blinks during error operation.
(3)	PUMP DOWN (L1)	Orange	Lights on during pump down operation.
(4)	LOW NOISE MODE (L2 and L3)	Orange	Lights on during "Low noise mode" when local setting is activated. (Lighting pattern of L2 and L3 indicates low noise level.)
(5)	PEAK CUT MODE (L4, L5, and L6)	Orange	Lights on during "Peak cut mode" when local setting is activated. (Lighting pattern of L4, L5, and L6 indicates peak cut level.)

Switch button		Function or operation method
SW107	MODE	Switches between "Local setting" and "Error code display".
SW108	SELECT	Switches between the individual "Local settings" and the "Error code displays".
SW109	ENTER	Switches between the individual "Local settings" and the "Error code displays".
SW112	EXIT	Returns to "Operation status display".
SW110	PUMP DOWN	Starts the pump down operation.

■ Function setting table

No.	Setting item		LED display								Factory setting	
			POWER MODE	ERROR	PUMP DOWN (L1)	LOW NOISE		PEAK CUT				
						(L2)	(L3)	(L4)	(L5)	(L6)		
1	Low noise mode setting	Level 1	Blink (9 times)	○	○	○	●	○	○	●	◆	
		Level 2		○	○	○	●	○	●	○		
2	Peak cut mode setting	Level 1		○	○	●	○	○	○	●	○	◆
		Level 2		○	○	●	○	○	●	○		
		Level 3		○	○	●	○	○	●	●		
		Level 4		○	○	●	○	●	○	○		

Sign "○": Lights off, "●": Lights on

No.	Setting item	Content
1	Low noise mode setting	By using the "Low noise mode", the limit of the noise level will be set to decrease the noise level. The mode comes in 2 levels which can be set accordingly. To turn on the mode, use the external input terminal (CN131). <ul style="list-style-type: none"> By using this mode, the cooling/heating performance may decrease. Depending on the operating condition, the noise level may not decrease even if the Low noise mode is on.
2	Peak cut mode setting	The capacity limit can be selected when operating with the "Peak Cut mode." The operation selection can be done by external input terminal (CN132). The lower the level, the more the effect of energy saving, but the cooling/heating performance decreases.

• Noise level as low noise mode setting

Unit: dB (A)

	AOYG72LRLA		AOYG90LRLA	
	Cooling	Heating	Cooling	Heating
Level1	53	53	53	55
Level2	51	51	51	53

13-2. Local setting procedure

NOTE: Before performing the function setting, be sure to stop the operation of the air conditioner.

Low noise mode

- Press the MODE switch button (SW107) for 3 seconds or more to switch to “Local setting mode”.
- After confirming the LED lamp of POWER/MODE blinks 9 times, press the ENTER switch button (SW109).

POWER MODE	ERROR	PUMP DOWN (L1)	LOW NOISE (L2) (L3)		PEAK CUT (L4) (L5) (L6)		
Blinks (9 times)	○	○	○	○	○	○	○

Sign “○”: Lights off

- Press the SELECT switch button (SW108), and adjust the LED lamp as shown below. Then the LED lamp indicates the current setting.

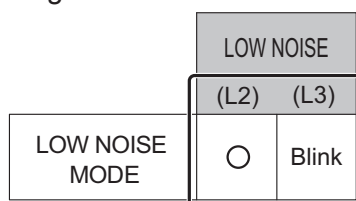

- Press the ENTER switch button (SW109).

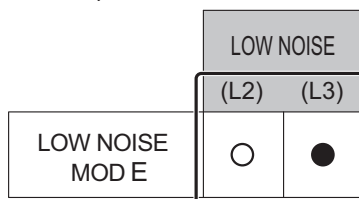

Sign “●”: Lights on

- Press the SELECT switch button (SW108), and adjust the LED lamps as shown below.

		PEAK CUT (L4) (L5) (L6)		
Level 1	Low	○	○	Blink
Level 2	Lower	○	Blink	○

- Press the ENTER switch button (SW109) and fix it.

		PEAK CUT (L4) (L5) (L6)		
Level 1	Low	○	○	●
Level 2	Lower	○	●	○

- To return to “Operating status display (Normal operation)”, press the EXIT switch button (SW112).

In case of missing how many times you pressed the SELECT and ENTER switch buttons:

- To return to “Operation status display (Normal operation)”, press the EXIT switch button once.
- Restart from the beginning of setting procedure.

NOTE: In case of missing how many times you pressed the SELECT and ENTER switch buttons, you must redo the setting procedure. Return to “Operation status display (Normal operation)” by pressing the EXIT switch button once, and restart from the beginning of the setting procedure.

■ Peak cut mode

1. Press the MODE switch button (SW107) for 3 seconds or more to switch to “Local setting mode”.
2. After confirming the LED lamp of POWER/MODE blinks 9 times, press the ENTER switch button (SW109).

POWER MODE	ERROR	PUMP DOWN (L1)	LOW NOISE		PEAK CUT		
			(L2)	(L3)	(L4)	(L5)	(L6)
Blinks (9 times)	○	○	○	○	○	○	○

Sign “○”: Lights off

3. Press the SELECT switch button (SW108), and adjust the LED lamp as shown below. Then the LED lamp indicates the current setting.

PEAK CUT MODE	LOW NOISE	
	(L2)	(L3)
	Blink	○

4. Press the ENTER switch button (SW109).

PEAK CUT MODE	LOW NOISE	
	(L2)	(L3)
	●	○

Sign “●”: Lights on

5. Press the SELECT switch button (SW108), and adjust the LED lamps as shown below.

		PEAK CUT		
		(L4)	(L5)	(L6)
Level 1	0% of rated input ratio	○	○	Blink
Level 2	50% of rated input ratio	○	Blink	○
Level 3	75% of rated input ratio	○	Blink	Blink
Level 4	100% of rated input ratio	Blink	○	○

Sign “○”: Lights off

6. Press the ENTER switch button (SW109) and fix it.

		PEAK CUT		
		(L4)	(L5)	(L6)
Level 1	0% of rated input ratio	○	○	●
Level 2	50% of rated input ratio	○	●	○
Level 3	75% of rated input ratio	○	●	●
Level 4	100% of rated input ratio	●	○	○

Sign “○”: Lights off, “●”: Lights on

7. To return to “Operating status display (Normal operation)”, press the EXIT switch button (SW112).

NOTE: When pressed number is lost during setting, you must redo the setting procedure. Return to “Operation status display (Normal operation)” by pressing the EXIT switch button once, and restart from the beginning of the setting procedure.