

■ Model: ARXC096GTEH

Unit: mm

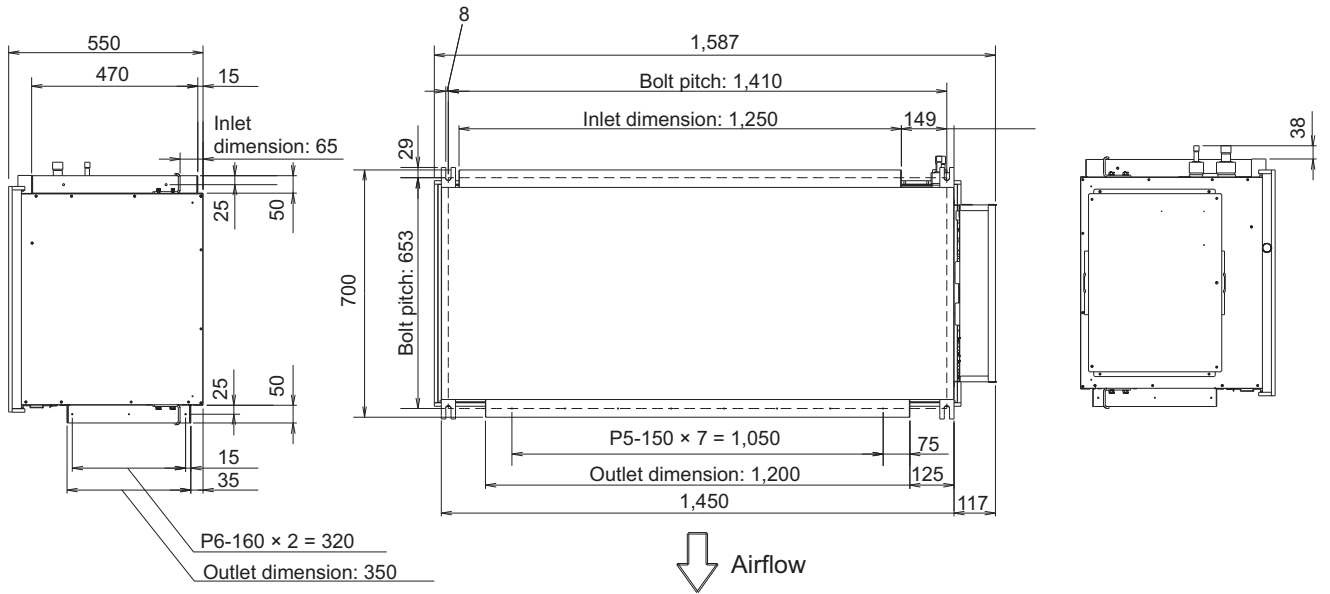
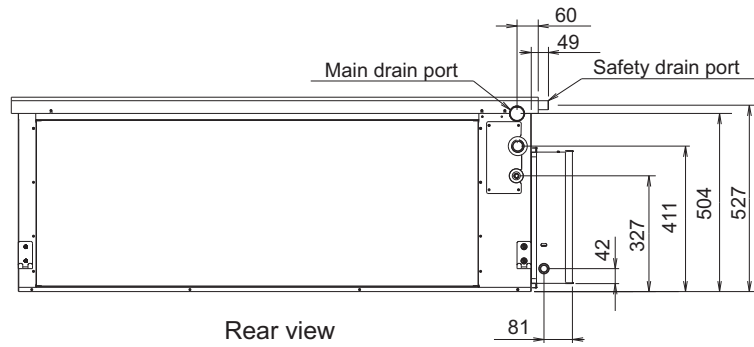

Side view (L)

Top view

Side view (R)

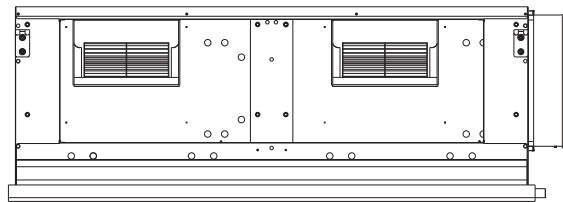

INDOOR
UNITS

INDOOR
UNITS

■ Installation space requirement

Unit: mm

- When service access will be carried out above the indoor unit, a recommended installation space of 450 mm is required.

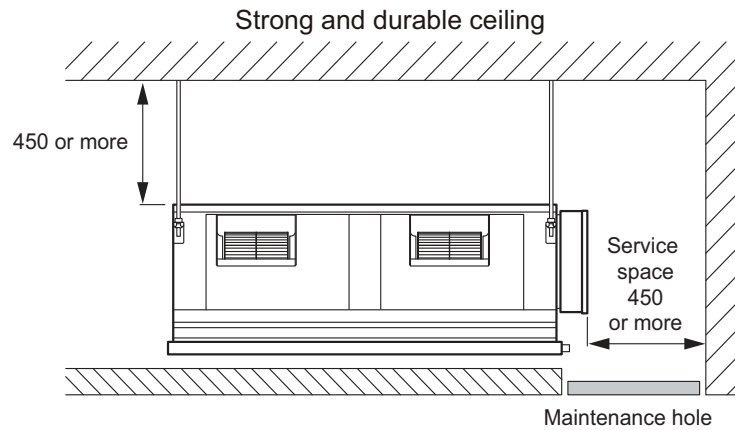

- Installation by which service is carried out from the bottom of the unit.

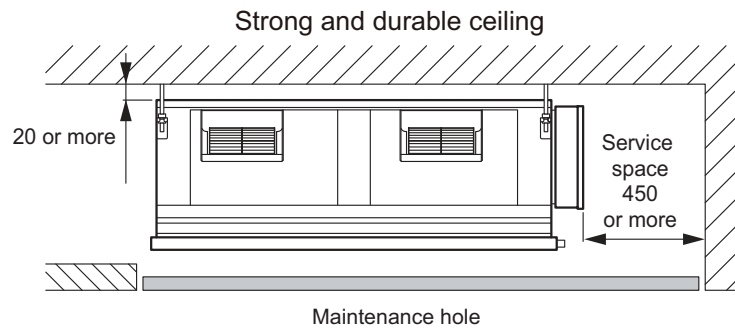

■ Maintenance space requirement

For future maintenance and service access, provide sufficient maintenance space.

NOTE: Do not place any wiring or illumination in the maintenance space, as they will impede service.

Unit: mm

