

3-6. SLIM DUCT / SLIM CONCEALED FLOOR TYPE

■ MODELS: ARXD04GALH, ARXD07GALH, ARXD09GALH, ARXD12GALH, ARXD14GALH

(Unit : mm)

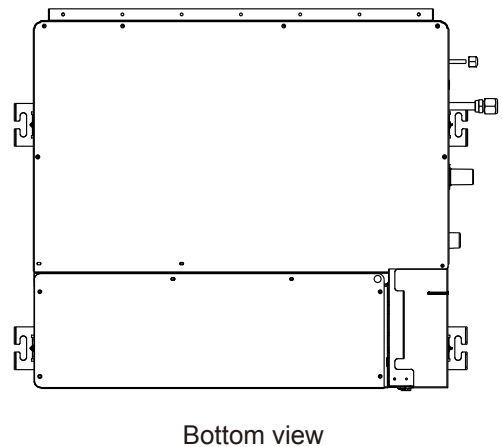
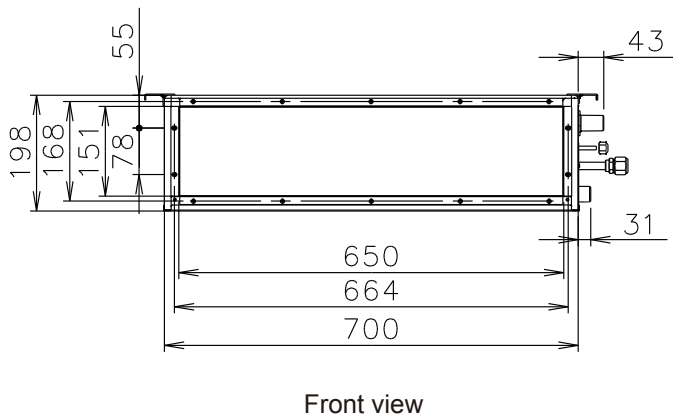
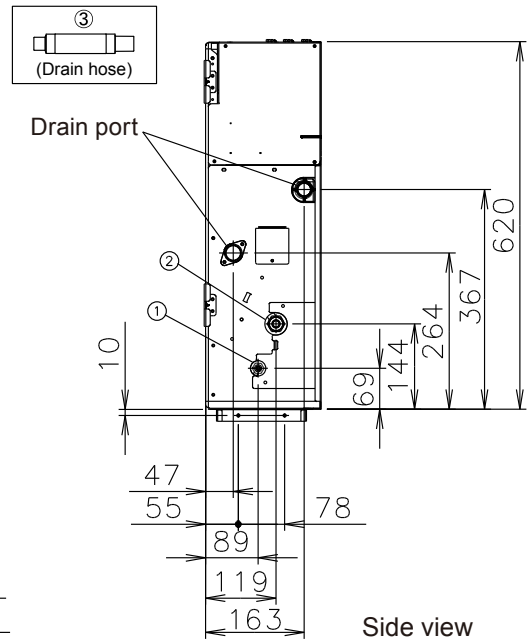
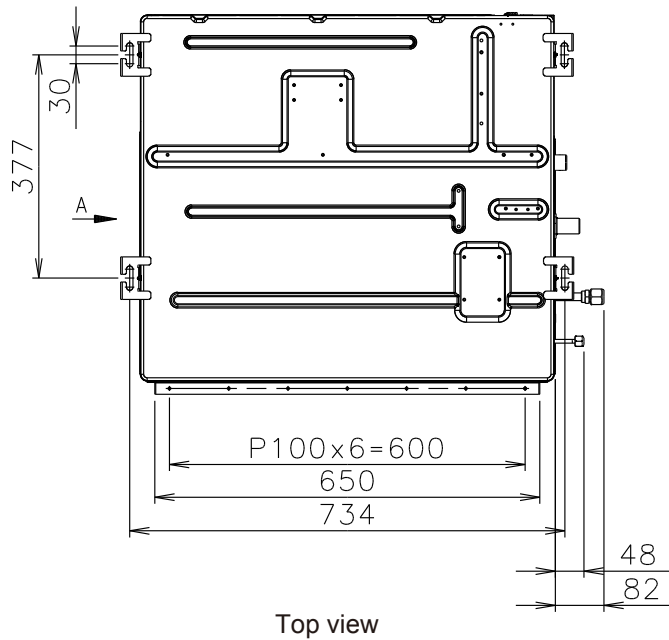
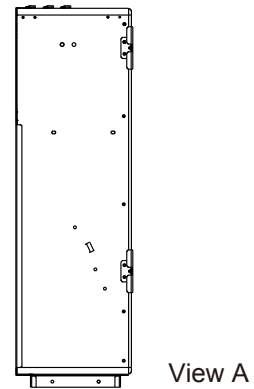
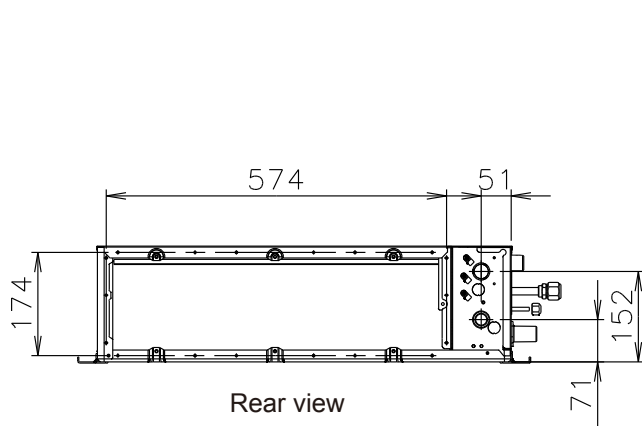

			ARXD04, ARXD07, ARXD09, ARXD12, ARXD14
①	Refrigerant pipe flare connection	Liquid	ø 6.35 mm
②		Gas	ø 12.70 mm
③	Drain hose		VP25 [ø 25mm(I.D.) ; ø 32mm(O.D.)]

INDOOR UNITS

INDOOR UNITS

■ INSTALLATION PLACE

Strong and durable ceiling

(Unit : mm)

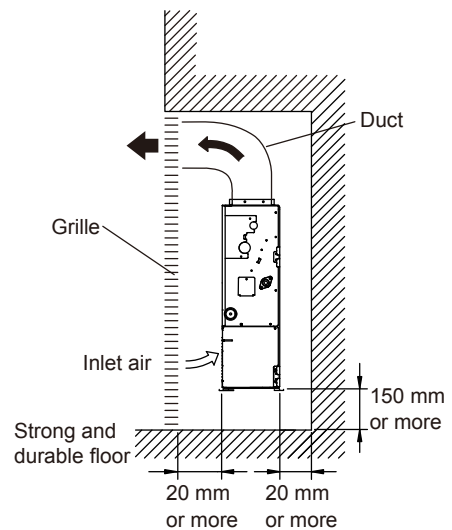
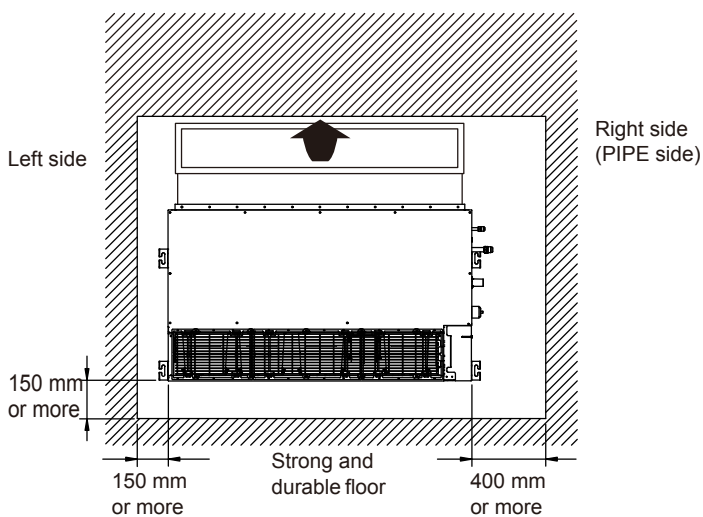
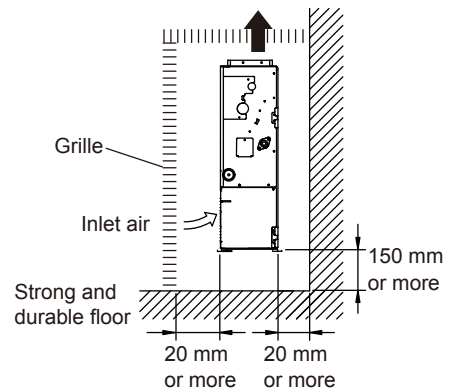
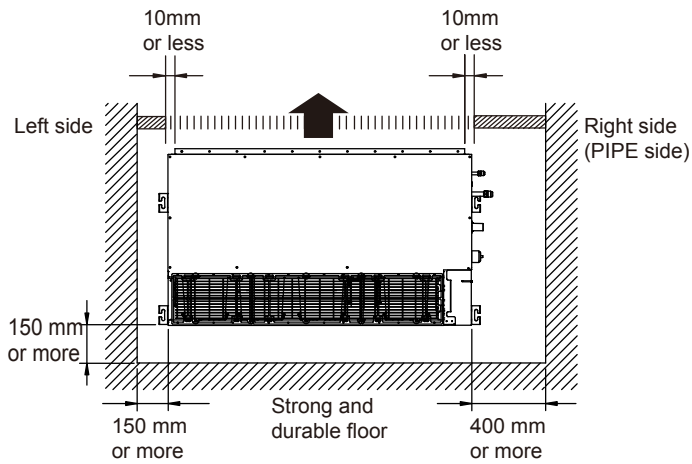
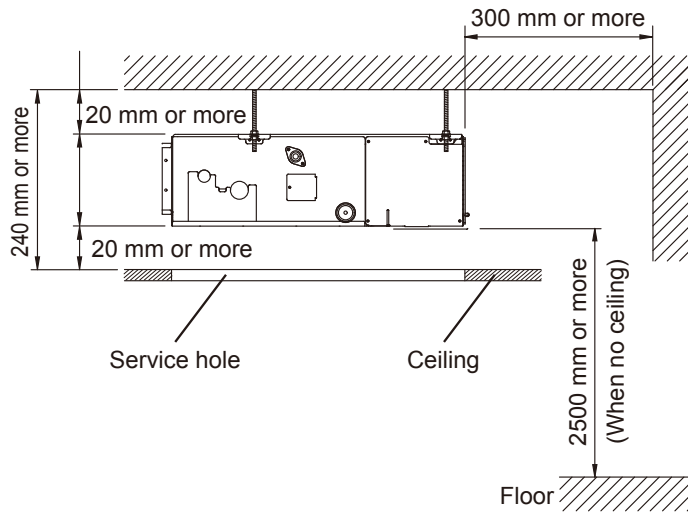
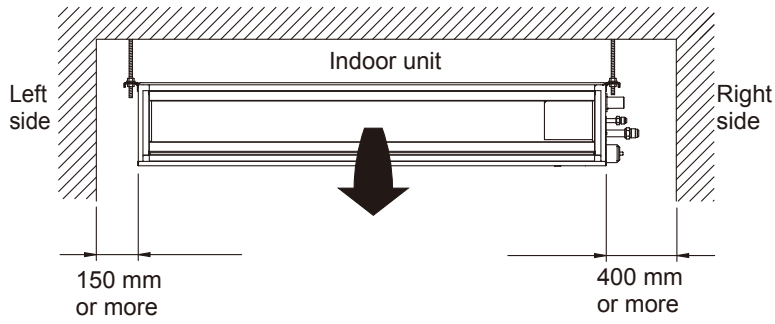

INDOOR UNITS

INDOOR UNITS

■ MAINTENANCE SPACE

Provide a service access for inspection purposes as shown below.
Do not place any wiring or illumination in the service space, as they will impede service.

(Unit : mm)

