

3-2. Mini duct type

■ Models: ARXG07KSLAP, ARXG09KSLAP, ARXG12KSLAP, and ARXG14KSLAP

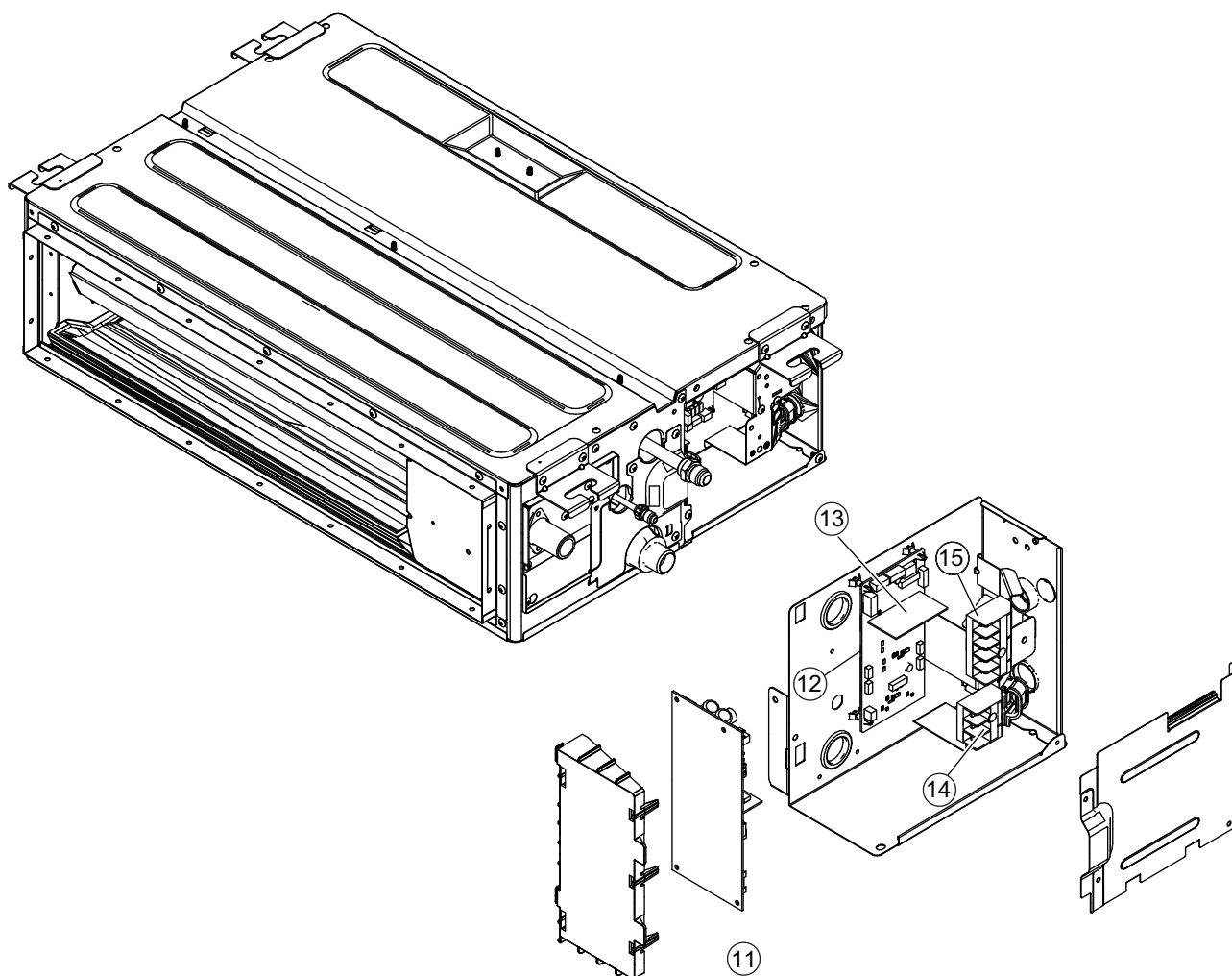

Item no.	Part no.	Part name	Service part
11	9710661020	Power supply PCB	◆
12	9710624261	Main PCB (For 07 model)	◆
	9710624278	Main PCB (For 09 model)	◆
	9710624285	Main PCB (For 12 model)	◆
	9710624292	Main PCB (For 14 model)	◆
13	9710019005	2-way remote PCB	◆
14	9900568009	Terminal 3P	◆
15	9900896003	Terminal 3P (For wired remote controller)	◆
—	9900653033	Room thermistor	◆
—	9900942021	Pipe thermistor	◆

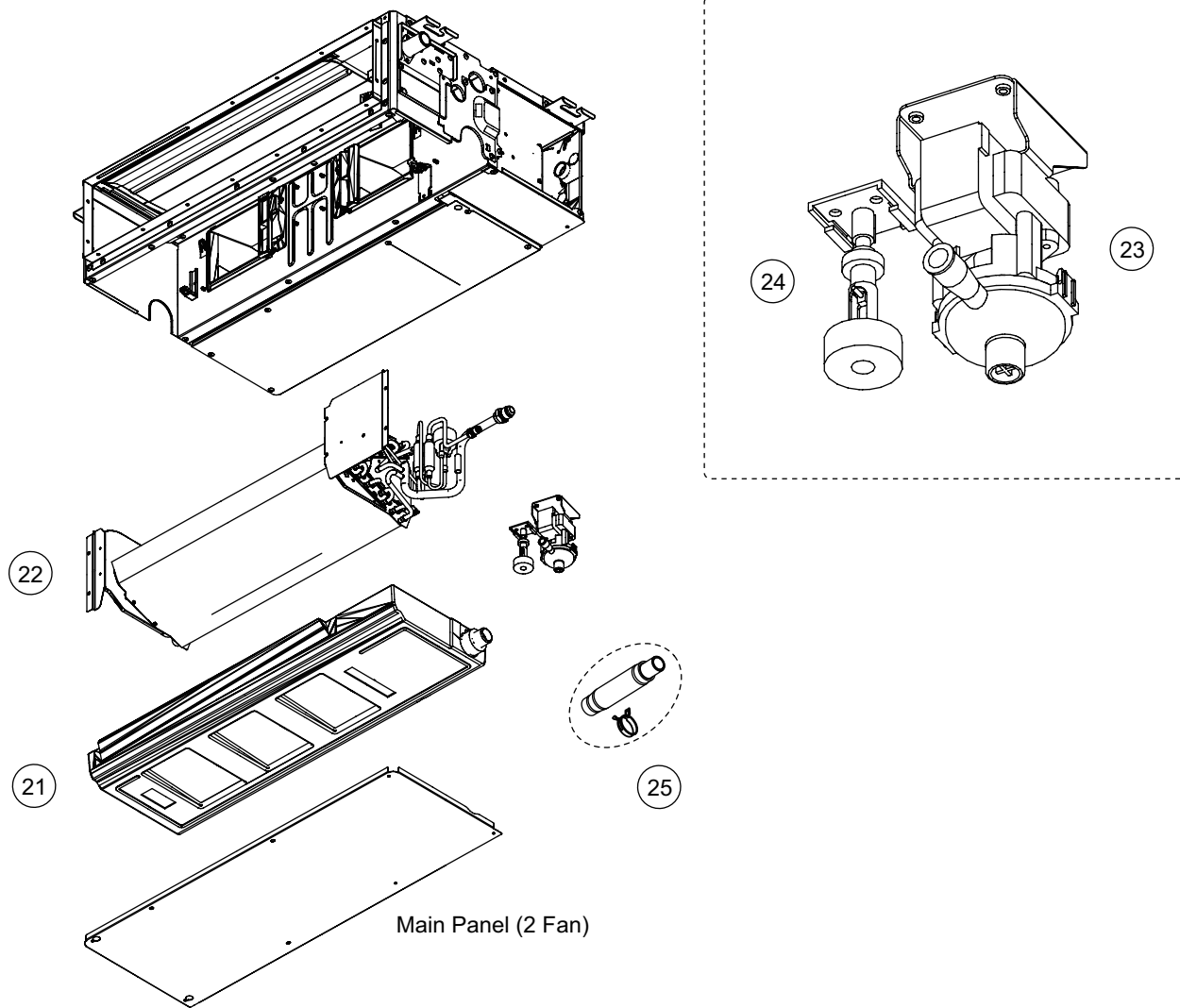

Item no.	Part no.	Part name	Service part
21	9381930111	Drain pan sub assy	◆
22	9381933440	Evaporator total assy	◆
23	9900472061	Pump assy	◆
24	9900465063	Float switch	◆
25	9378450097	Hose sub assy	◆

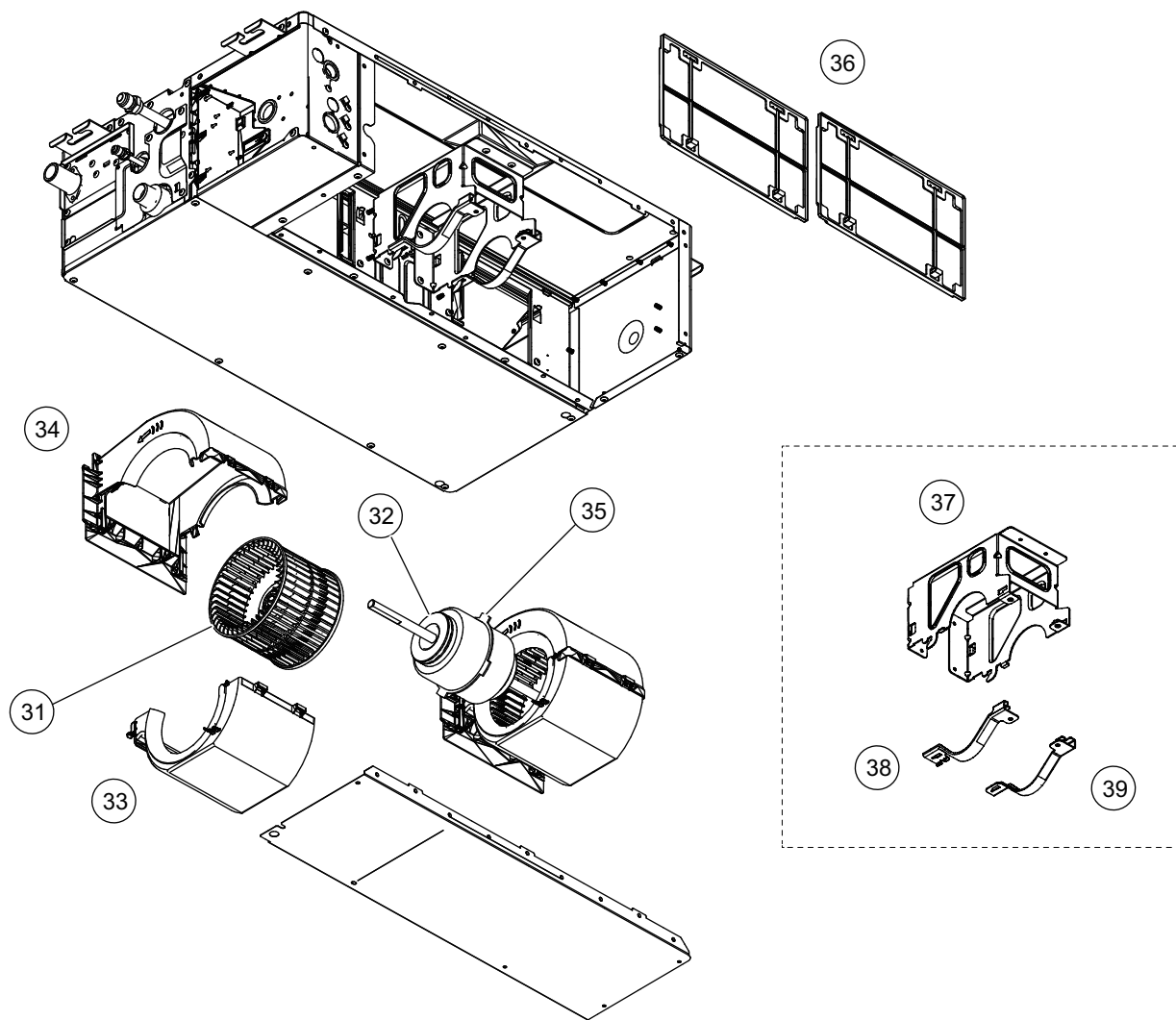

Item no.	Part no.	Part name	Service part
31	9379570015	Sirocco fan assy	◆
32	9381673001	Rubber (Vibration proof)	◆
33	9381676002	Casing B	◆
34	9381677016	Casing U	◆
35	9380636038	Fan motor assy (For 07 model)	◆
36	9379574006	Air filter	◆
37	9381675005	Motor bracket assy	◆
38	9381669004	Motor band L	◆
39	9381670000	Motor band R	◆