

ARXG14KLLAP

Please visit our webstore for full product and technical documentation 

Unit Type	Slim Ducted	
Remote Controller	Option	
Nominal Cooling Capacity (kW)	4.3	
Nominal Heating Capacity (kW)	5.0	
Height (mm)	198	
Width (mm)	700	
Depth (mm)	620	
Weight (kg)	17	
Standard Static Pressure (Pa)	25	
Static Pressure Ranget (Pa)	0 to 90	
Airflow Rate - Cooling - High (m3/h)	800	
Airflow Rate - Heating - High (m3/h)	800	
Sound Pressure Level - Cooling - High (dB(A))	32	
Sound Pressure Level - Cooling - Low (dB(A))	26	
Sound Pressure Level - Heating - High (dB(A))	32	
Sound Pressure Level - Heating - Low (dB(A))	25	
Sound Power Level - Cooling - High (dB(A))	60	
Sound Power Level - Heating - High (dB(A))	60	
Moisture Removal (l/h)	1.5	
Refrigerant Type (Global Warming Potential)	R32 (675)	
Liquid Pipe Size	1/4"	
Gas Pipe Size	3/8"	
Unit Power Supply	From Outdoor Unit	



Document Downloads

- [Airflow - Fan Curve](#)
- [Controls & Accessories](#)
- [Dimensional Drawing](#)
- [Electrical Characteristics](#)
- [Function Settings](#)
- [Inputs & Outputs](#)
- [Installation Manual](#)
- [Noise Curve](#)
- [Operation Manual](#)

- [Product Image](#)
- [Spare Parts List All Pages](#)
- [Specifications](#)
- [Wiring Diagram](#)

Related Items

- [AOYG14KATA](#) 4.3kW Economy Outdoor Unit - R32 Single Phase
- [AOYG14KBTB](#) 4.3kW Standard Outdoor Unit - R32 Single Phase
- [AOYG14KBTA2](#) 4.0kW 2 Way Multi Outdoor Unit - R32 1 Ph
- [AOYG18KBTA2](#) 5.0kW 2 Way Multi Outdoor Unit - R32 1 Ph
- [AOYG18KBTA3](#) 5.4kW 3 Way Multi Outdoor Unit - R32 1 Ph
- [AOYG24KBTA3](#) 6.8kW 3 Way Multi Outdoor Unit - R32 1 Ph
- [AOYG30KBTA4](#) 8.0kW 4 Way Multi Outdoor Unit - R32 1 Ph
- [AOYG36KBTA5](#) 10.0kW 5 Way Multi Outdoor Unit - R32 1 Ph
- [UTYRNRZY5](#) Touch Screen Remote Controller
- [UTYTFSXZ1](#) Wireless LAN interface
- [UTZVXAA](#) Fresh Air Intake Kit for Compact Cassette
- [UTDGXTAW](#) Auto Louvre Grille Kit (Size 07-14 IU's)
- [UTYRCRYZ1](#) Compact Simple Remote controller
- [UTYRVNYM](#) LCD Wired Remote Controller
- [UTYRHRY](#) Simple Remote Controller (without Master Control)
- [UTYRSRY](#) Simple Remote Controller (with Master Control)
- [UTYRSNYM](#) Simplified Wired Remote Controller
- [UTYTERX](#) External switch controller
- [FJRCWIF11](#) IntesisHome Wireless LAN Adapter for Splits & VRF
- [UTYXSZX](#) Remote Sensor Unit (for All Duct type)
- [UTYLBTYM](#) Infra-Red Receiver Kit, Receiver Wire -9710358012
- [UTYVTGX](#) Splits Network Converter (DC Powered)
- [UTYVTGXV](#) Splits Network Converter (AC Powered)
- [UTYXWZXZG](#) External Connect Kit

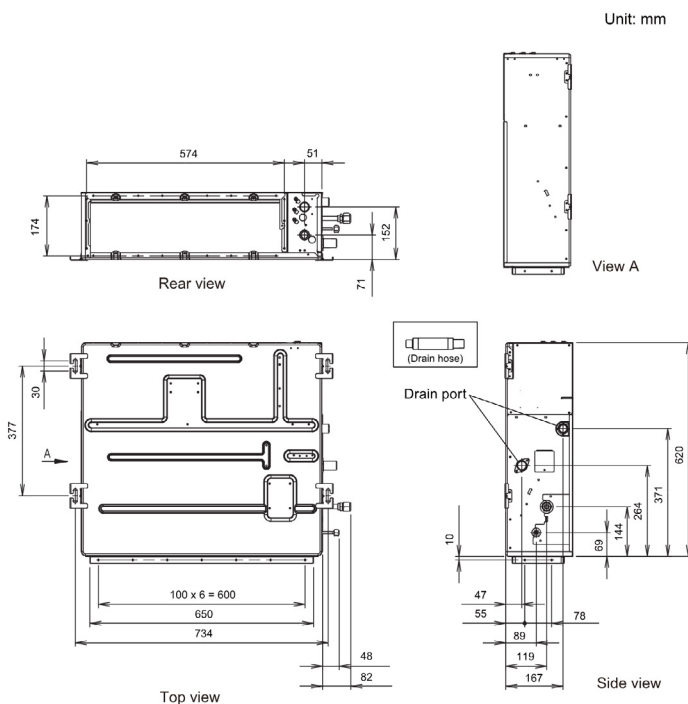

*Specifications and design are subject to change without notice for further improvement.
 *Actual products' colors may be different from the colors shown in this printed material.