

2. Dimensions

2-1. Model: ARXG22KMLA

Unit: mm

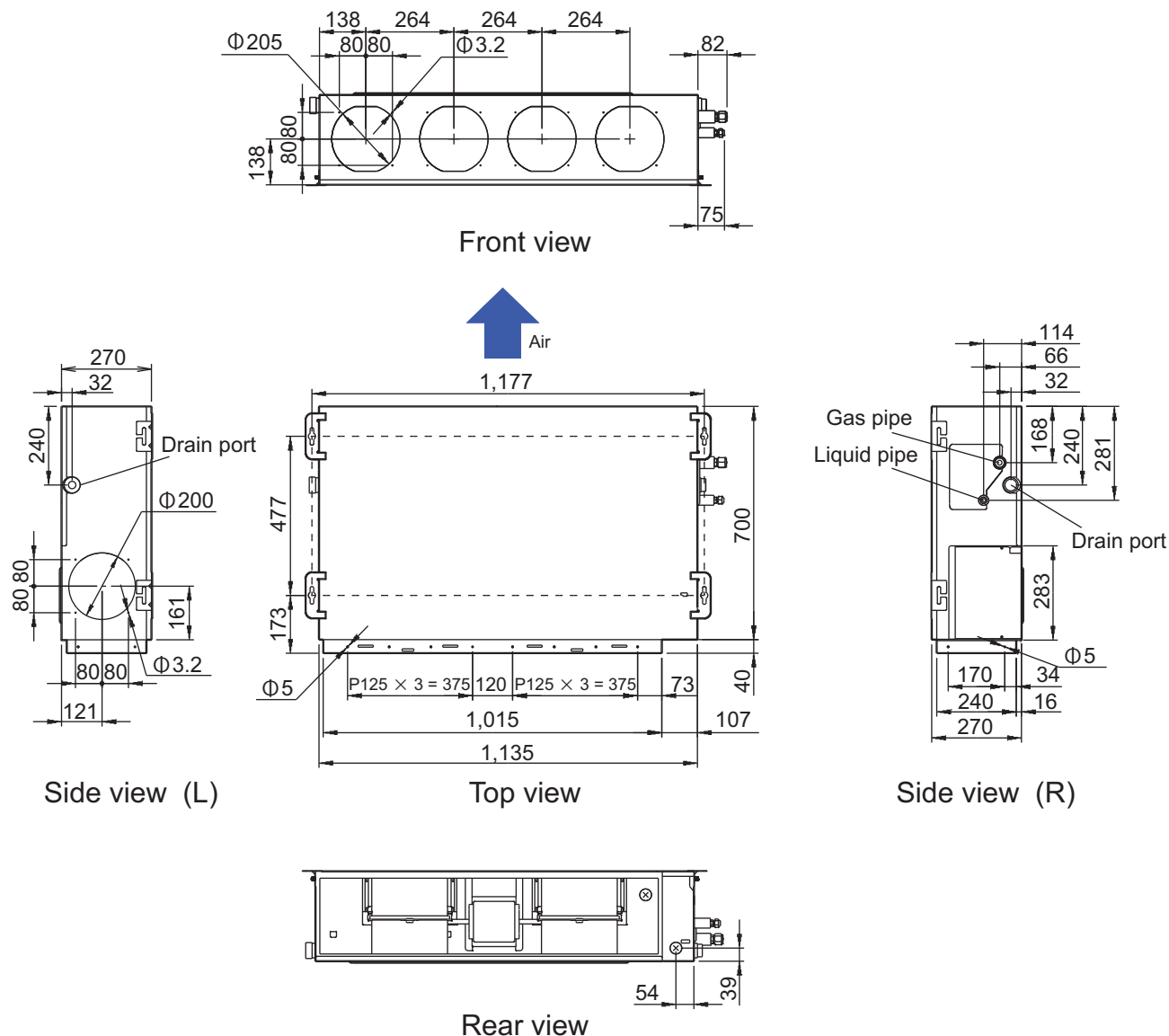

2-2. Installation space requirement

Provide sufficient installation space for product safety.

■ Model: ARXG22KMLA

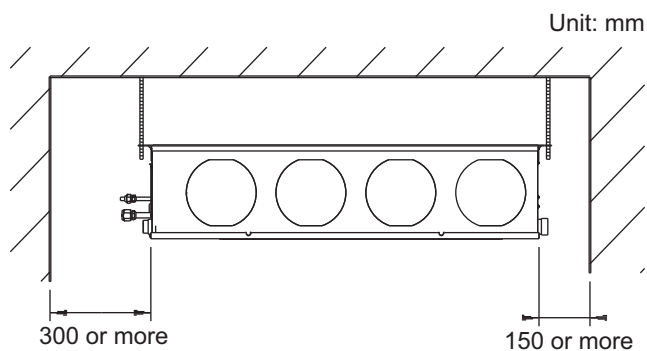

2-3. Maintenance space requirement

For future maintenance and service access, provide sufficient maintenance space.

NOTE: Do not place any wiring or illumination in the maintenance space, as they will impede service.

■ Model: ARXG22KMLA

Unit: mm

- Provide a service access for maintenance purposes.

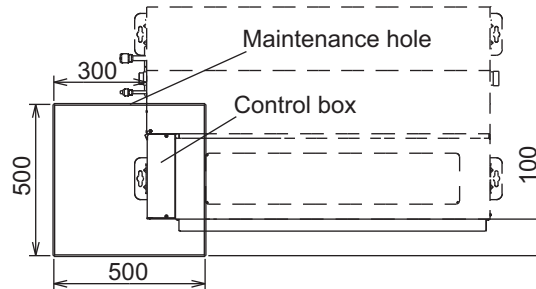

- The service access necessary for fan units and filter maintenance.

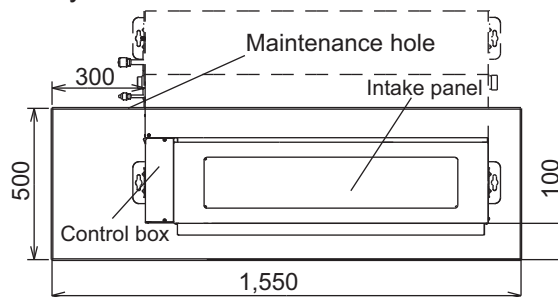

- When using a square duct

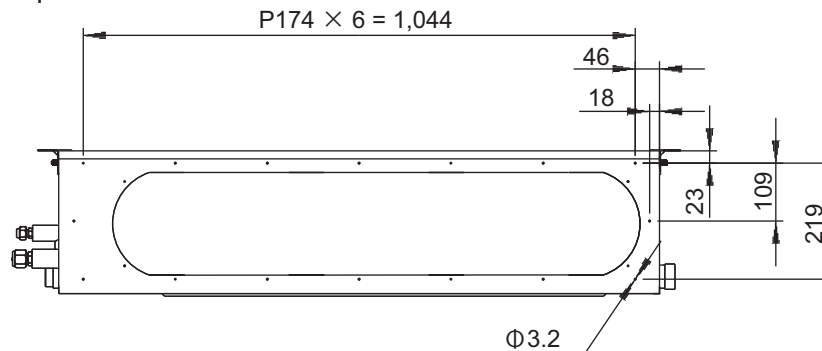

- Bottom air intake hole

