

### ARXG22KMLA

Please visit our webstore for full product and technical documentation 

|   |                      |
|---|----------------------|
| Unit Type                                     | Medium Static Ducted |
| Remote Controller                             | Option               |
| Nominal Cooling Capacity (kW)                 | 6.0                  |
| Nominal Heating Capacity (kW)                 | 7.0                  |
| Height (mm)                                   | 270                  |
| Width (mm)                                    | 1135                 |
| Depth (mm)                                    | 700                  |
| Weight (kg)                                   | 35                   |
| Filter  | UTDLF25NA / UTRDF204 |
| Standard Static Pressure (Pa)                 | 35                   |
| Static Pressure Ranget (Pa)                   | 30 to 150            |
| Airflow Rate - Cooling - High (m3/h)          | 1100                 |
| Airflow Rate - Heating - High (m3/h)          | 1100                 |
| Sound Pressure Level - Cooling - High (dB(A)) | 31                   |
| Sound Pressure Level - Cooling - Low (dB(A))  | 25                   |
| Sound Pressure Level - Heating - High (dB(A)) | 31                   |
| Sound Pressure Level - Heating - Low (dB(A))  | 25                   |
| Sound Power Level - Cooling - High (dB(A))    | 60                   |
| Sound Power Level - Heating - High (dB(A))    | 62                   |
| Moisture Removal (l/h)                        | 2.1                  |
| Refrigerant Type (Global Warming Potential)   | R32 (675)            |
| Liquid Pipe Size                              | 1/4"                 |
| Gas Pipe Size                                 | 1/2"                 |
| Unit Power Supply                             | From Outdoor Unit    |

Unit: mm

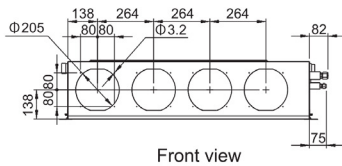

Front view

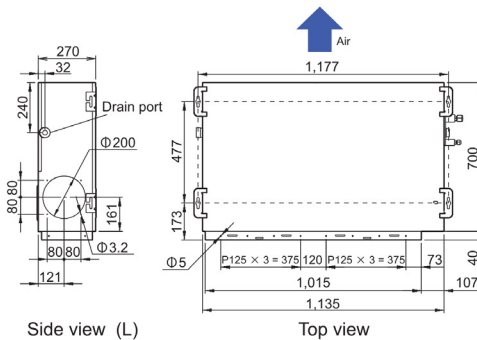

Side view (L)

Top view

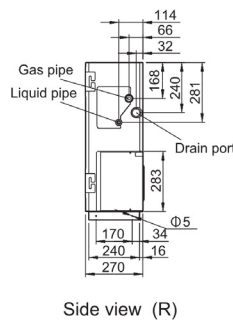

Side view (R)

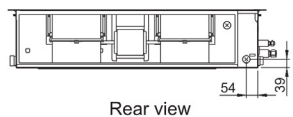

Rear view

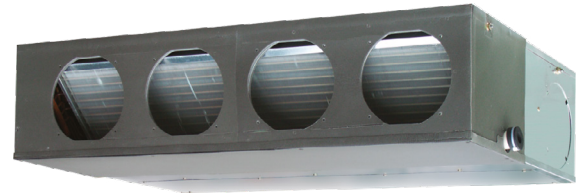

#### Document Downloads

- [Airflow - Fan Curve](#)
- [Controls & Accessories](#)
- [Dimensional Drawing](#)
- [Function Settings](#)
- [Inputs & Outputs](#)
- [Installation Manual](#)
- [Noise Curve](#)
- [Operation Manual](#)
- [Product Image](#)

- [Spare Parts List All Pages](#)
- [Specifications](#)
- [Wiring Diagram](#)

#### Related Items

- [AOYG22KATA](#) 6.0kW Economy Outdoor Unit - R32 Single Phase
- [AOYG22KBTB](#) 6.0kW Standard Outdoor Unit - R32 Single Phase
- [UTYRNRYZ5](#) Touch Screen Remote Controller
- [UTYFYSXZ1](#) Wireless LAN interface
- [UTDLF25NA](#) Long Life Filter Kit
- [UTDRF204](#) Flange (Round)
- [UTZPX1NBA](#) Drain Pump Unit for ARXA024-045GLEH
- [UTYRCRYZ1](#) Compact Simple Remote controller
- [UTYRVNYM](#) LCD Wired Remote Controller
- [UTYRHRY](#) Simple Remote Controller (without Master Control)
- [UTYRSRY](#) Simple Remote Controller (with Master Control)
- [UTYRSNYM](#) Simplified Wired Remote Controller
- [UTYTERX](#) External switch controller
- [FJRCWIFI1](#) IntesisHome Wireless LAN Adapter for Splits & VRF
- [UTYLBITYM](#) Infra-Red Receiver Kit, Receiver Wire -9710358012
- [UTYXSZX](#) Remote Sensor Unit (for All Duct type)
- [UTYXWZXZG](#) External Connect Kit
- [UTYVTGX](#) Splits Network Converter (DC Powered)
- [UTYVTGXV](#) Splits Network Converter (AC Powered)

\*Specifications and design are subject to change without notice for further improvement.  
 \*Actual products' colors may be different from the colors shown in this printed material.