

## 2. Dimensions

### 2-1. Models: ARXG24KMLA, ARXG30KMLA, ARXG36KMLA, and ARXG45KMLA

Unit: mm

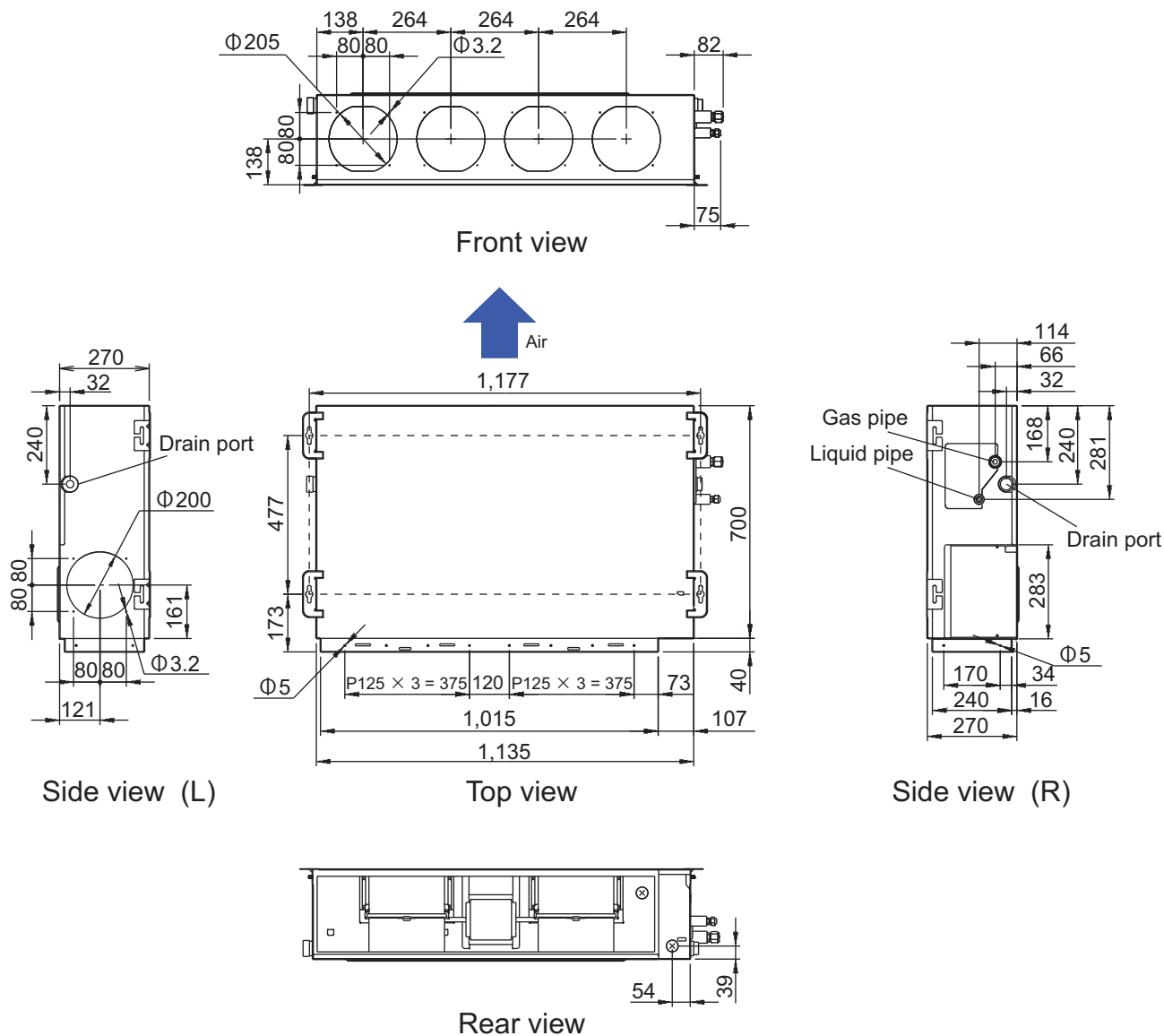

## 2-2. Installation space requirement

Provide sufficient installation space for product safety.

### ■ Models: ARXG24KMLA, ARXG30KMLA, ARXG36KMLA, and ARXG45KMLA

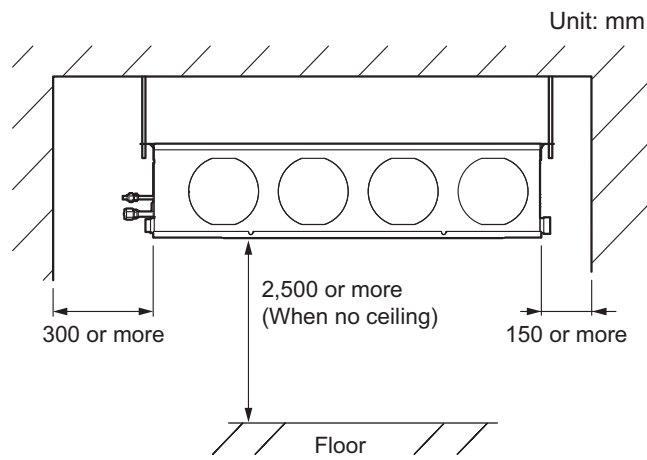

## 2-3. Maintenance space requirement

For future maintenance and service access, provide sufficient maintenance space.

**NOTE:** Do not place any wiring or illumination in the maintenance space, as they will impede service.

### ■ Models: ARXG24KMLA, ARXG30KMLA, ARXG36KMLA, and ARXG45KMLA

Unit: mm

- Provide a service access for maintenance purposes.

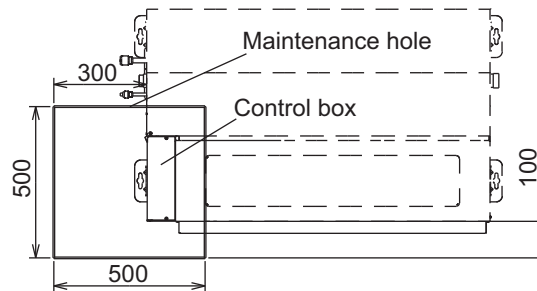

- The service access necessary for fan units and filter maintenance.

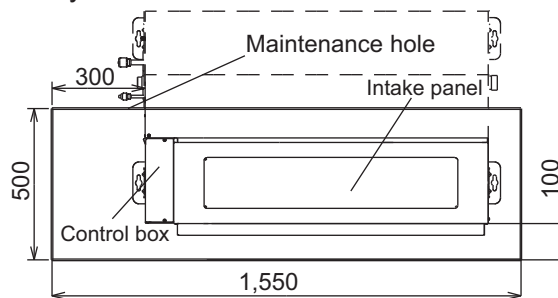

- When using a square duct

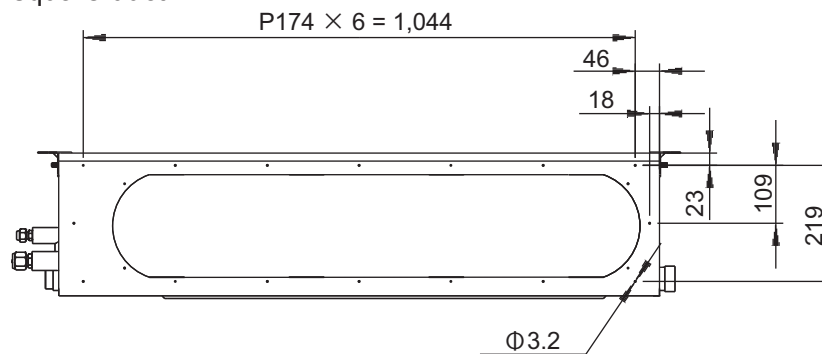

- Bottom air intake hole

