

2-2. Models: ARXG36KHTAP, ARXG45KHTAP, and ARXG54KHTAP

Unit: mm

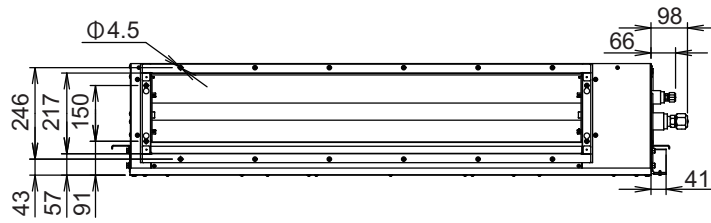

Front view

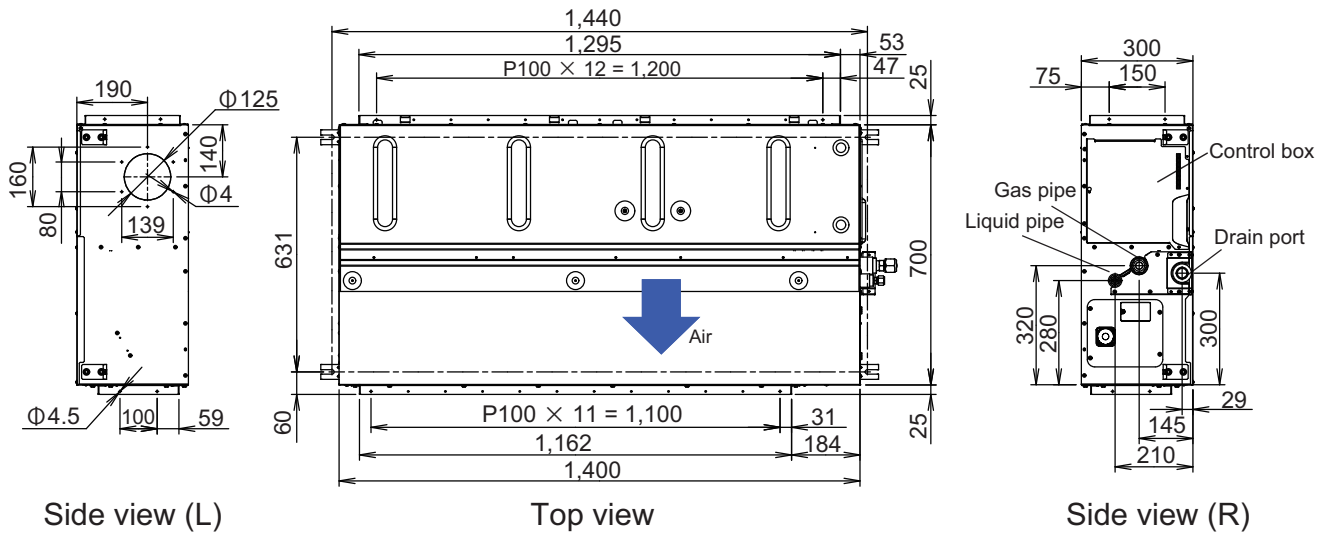
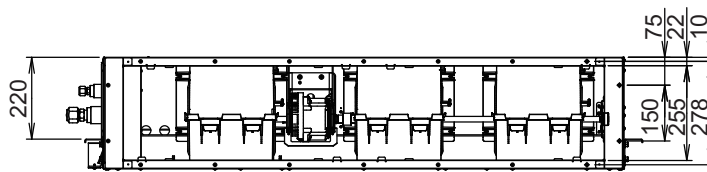

Rear view

2-3. Installation space requirement

Provide sufficient installation space for product safety.

■ Models: ARXG24KHTAP, ARXG30KHTAP, ARXG36KHTAP, ARXG45KHTAP, and ARXG54KHTAP

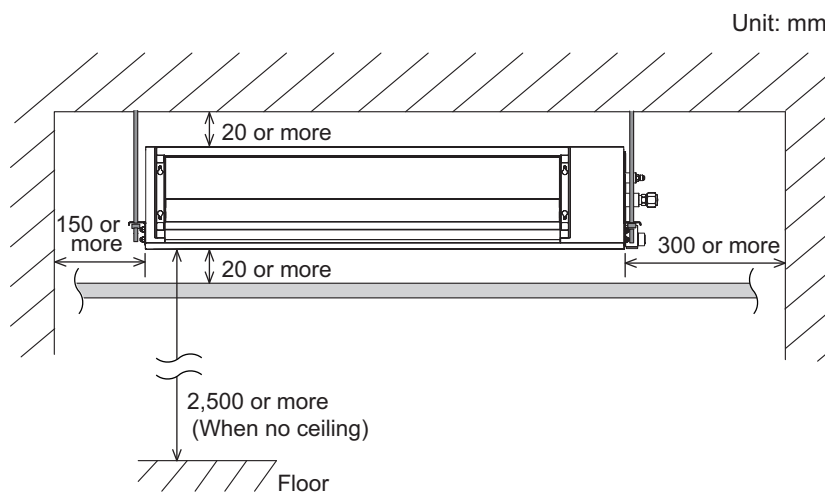

2-4. Maintenance space requirement

For future maintenance and service access, provide sufficient maintenance space.

NOTE: Do not place any wiring or illumination in the maintenance space, as they will impede service.

■ Models: ARXG24KHTAP, ARXG30KHTAP, ARXG36KHTAP, ARXG45KHTAP, and ARXG54KHTAP

- Provide a service access for maintenance purposes.

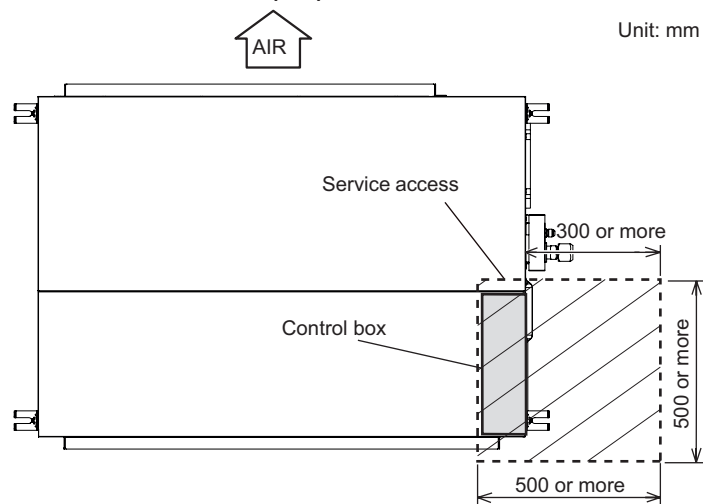

- The service access necessary for fan units and filter maintenance.

