

2. Dimensions

2-1. Models: ARXG45KHTA and ARXG54KHTA

Unit: mm

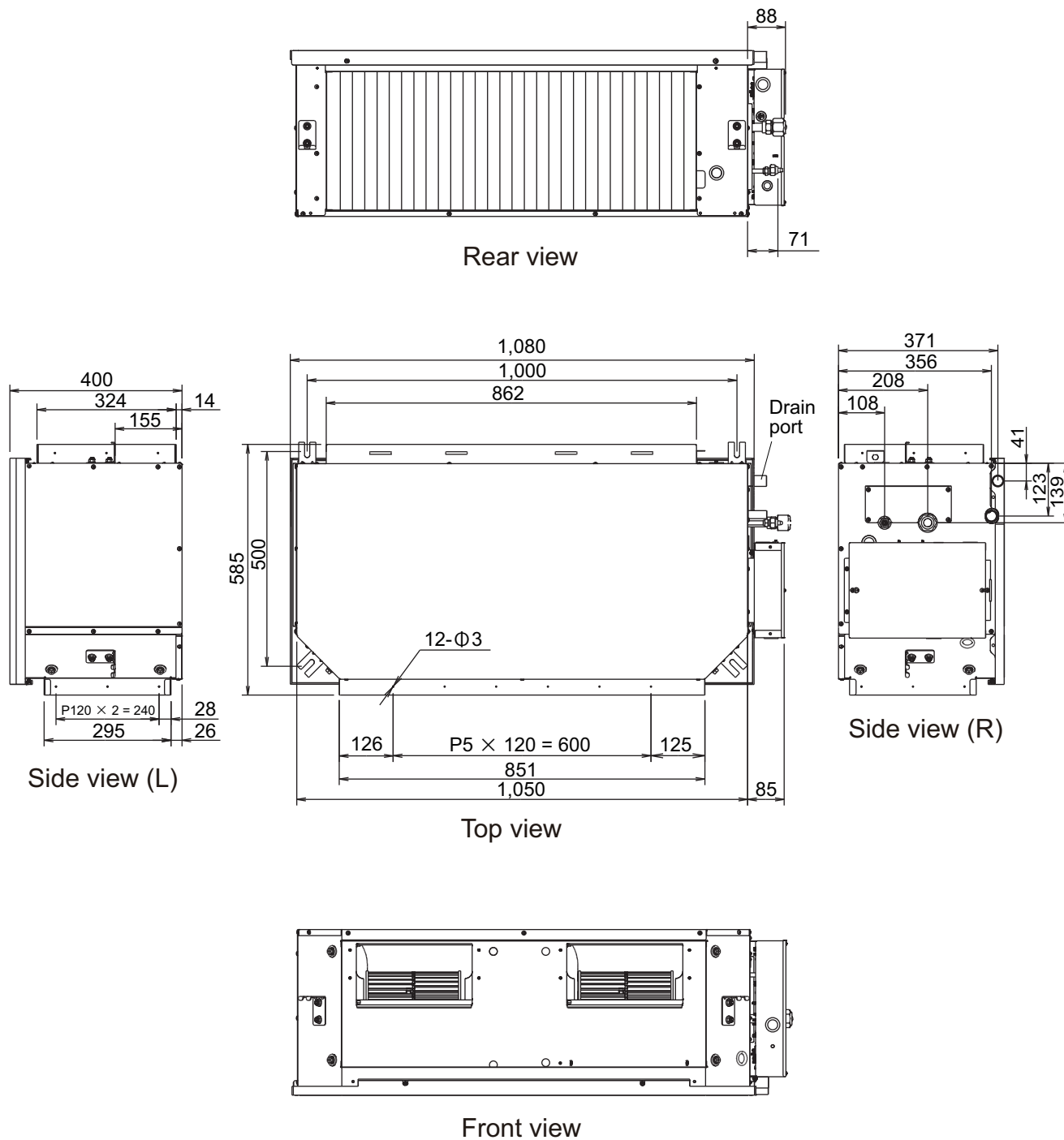

2-2. Installation space requirement

Provide sufficient installation space for product safety.

■ Models: ARXG45KHTA and ARXG54KHTA

Installation by which service space is made on top of the unit (recommended).

Unit: mm

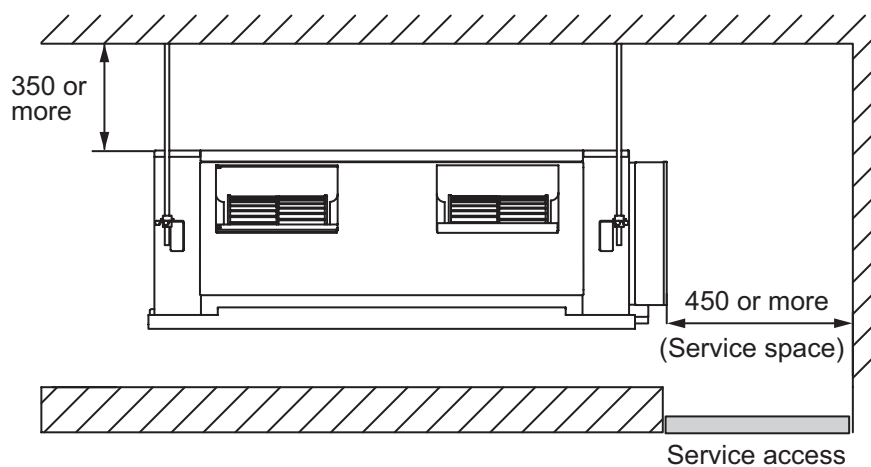

Installation by which service space is carried out from the bottom of the unit.

Unit: mm

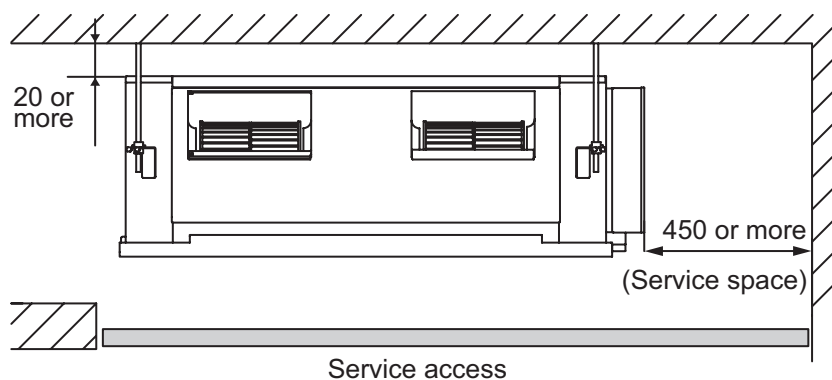

2-3. Maintenance space requirement

For future maintenance and service access, provide sufficient maintenance space.

NOTE: Do not place any wiring or illumination in the maintenance space, as they will impede service.

■ Models: ARXG45KHTA and ARXG54KHTA

Unit: mm

