

8. External input and output

Connector	Input	Output	Remarks
CN114	Control input	—	See external input/output settings for details.
CN115	—	Operation status output	
CN14	—	Fresh air control output	
CN15	—	Auxiliary heater output	

8-1. Preparation

Before connecting the external input, preparation is necessary using the signal wire in the figure below.



When the external input/output is used, connect the external signal wire as shown in the figure.

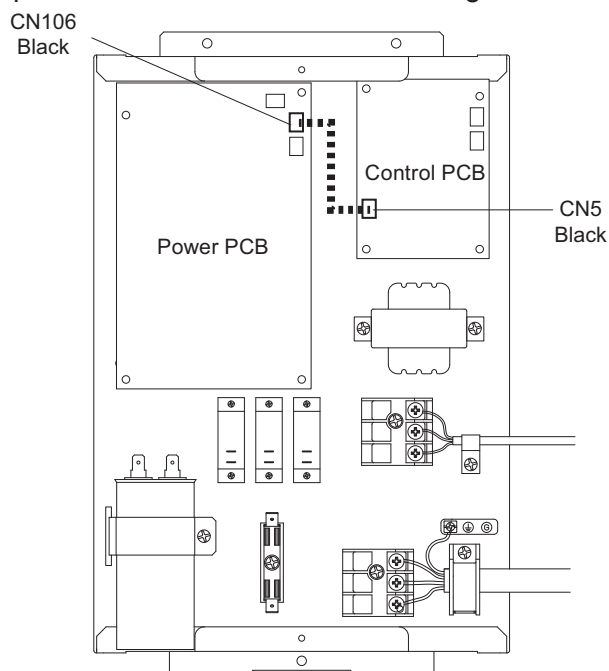

8-2. External input

- "Operation/Stop" mode or "Forced stop" mode can be selected with function setting of indoor unit.
- A twisted pair cable (22AWG) should be used. Maximum length of cable is 150 m.
- The wire connection should be separate from the power cable line.

■ Control input (Operation/Stop or Forced stop)

The air conditioner can be remotely operated by means of the following on-site work.

Operation is started at the following contents by adding the contact input of a commercial ON/OFF switch to a connector on the external control PCB and turning it ON.

Unit operation	Initial setting after power is on	Starting mode other than initial setting
Operation mode	Auto changeover	Mode at previous operation
Set temperature	24 °C	Temperature at previous operation
Airflow mode	AUTO	Mode at previous operation

● Circuit diagram example

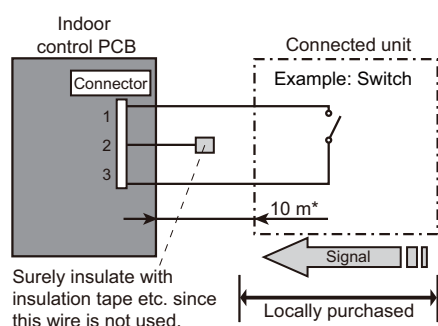

- Contact capacity: DC 5 V or more, 15 mA or more.
- Make the distance from the PCB to the connected unit within 10 m.
- Use non-polar relays and switches.

- When function setting is "Operation/Stop" mode

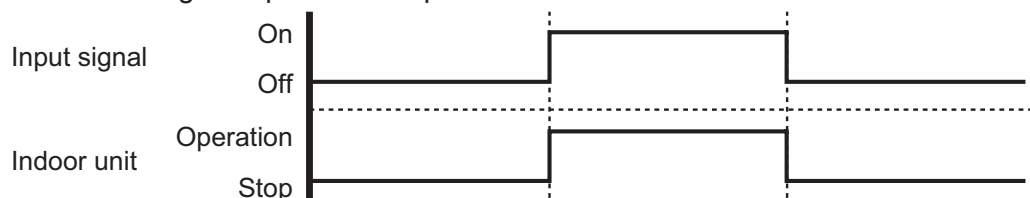

- When function setting is "Forced stop" mode

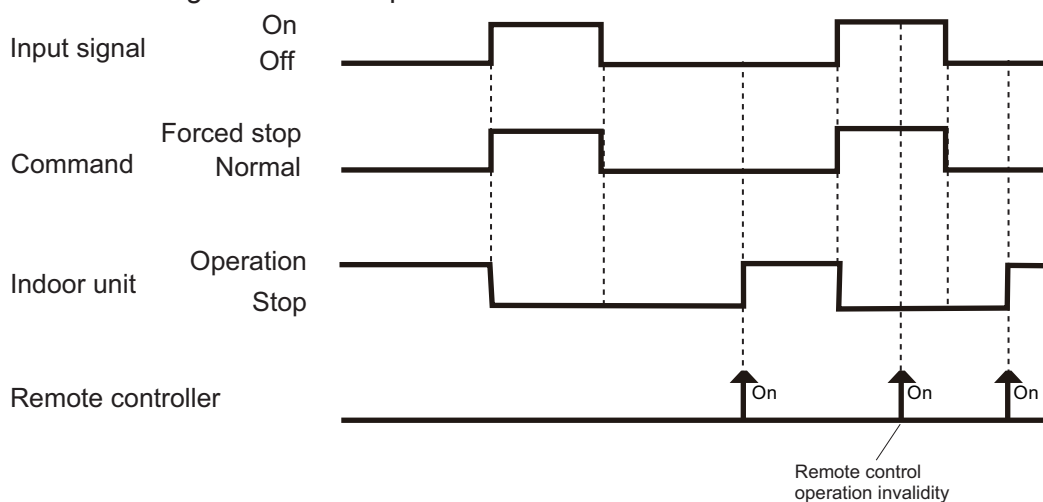

● Optional part

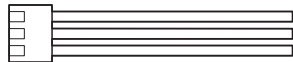
Model name	Exterior
UTD-ECS5A	External input wire 

8-3. External output

With using external output function, operating status of this product can be transmitted to the external device, and also, this product can be inter-connected with the external device.

■ Operation status output

● Circuit diagram example

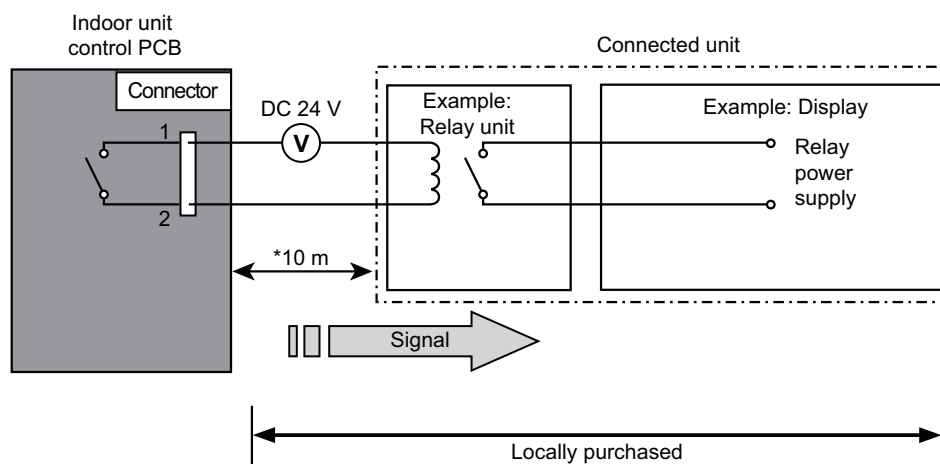

- *: Make the distance from the PCB to the connected unit within 10 m.
- Relay spec: Max. DC 24 V, 10 mA to less than 500 mA.

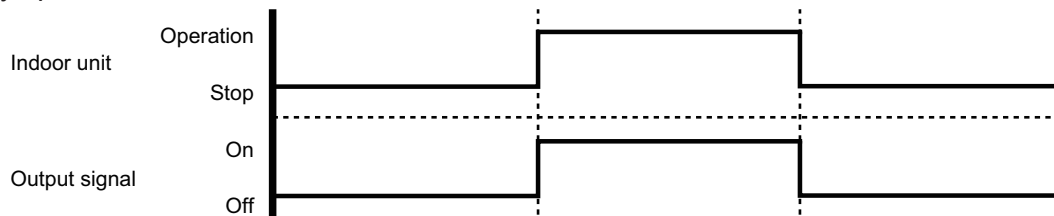

● Optional part

Model name	Exterior
UTD-ECS5A	External output wire 

■ Fresh-air control output

Signal linked to the indoor unit fan on can be output.

NOTE: In cold-air prevention control operation, the signal becomes off.

● Circuit diagram example

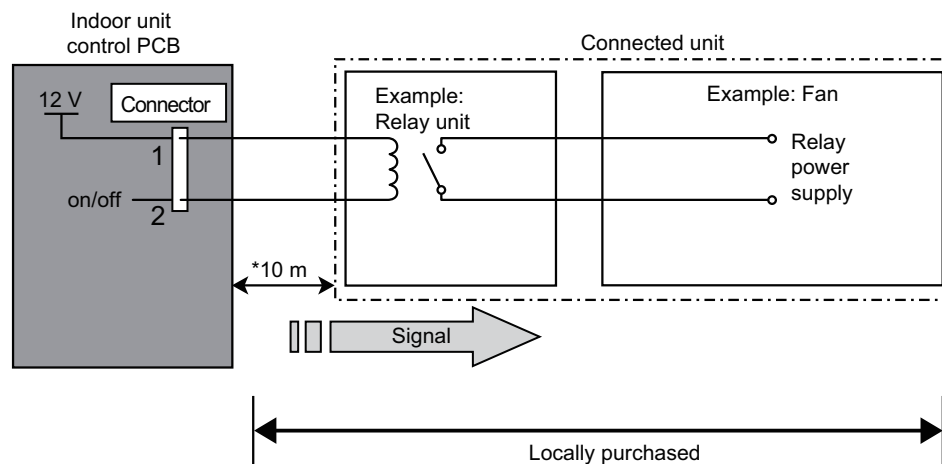

- *: Make the distance from the PCB to the connected unit within 10 m.
- Relay spec: Rated DC 12 V, 50 mA or less.

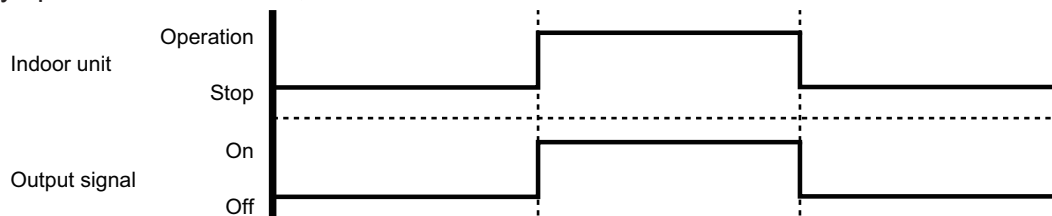

● Optional part

Model name	Exterior
UTD-ECS5A	Fresh-air output wire 

■ Auxiliary heater output

When indoor unit fan and compressor is turned on in heating operation, the signal is output from connector.

Specifications of the signal output performance are as shown as follows:

Example: When set temperature (T_s) is set at 22 °C;

- And room temperature (T_r) increase above 12 °C, signal output is ON.
- And T_r increase above 21 °C, signal output is OFF.
- And T_r decrease below 19 °C, signal output is ON.
- And T_r decrease below 10 °C, signal output is OFF.

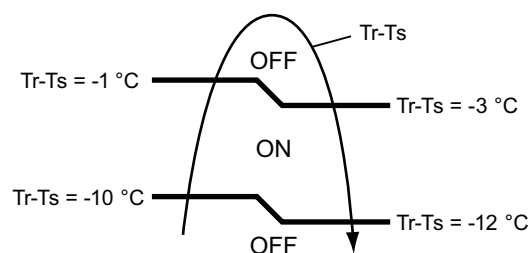

● Fan delay setting

This is used to continue the indoor unit fan operation for 1 minute after thermo OFF in heating mode.

For the detail setting on fan delay setting, refer to "Function settings on indoor unit" in "Function settings" on page 24.

● Circuit diagram example

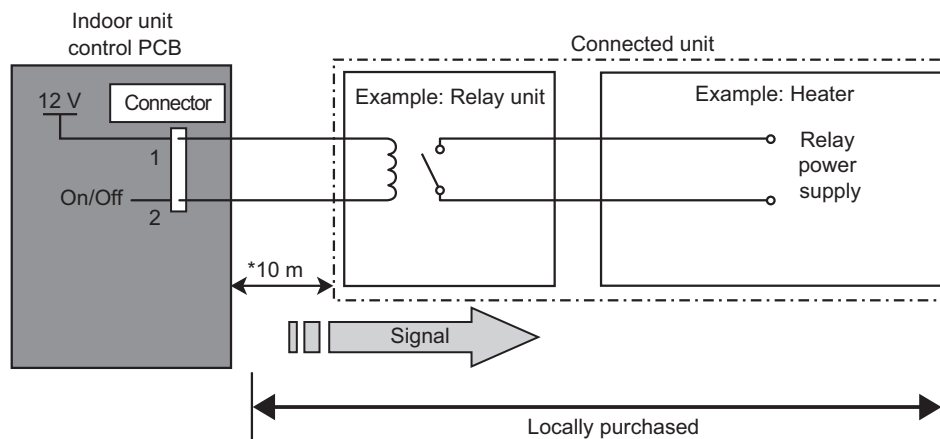

- *: Make the distance from the PCB to the connected unit within 10 m.
- Relay spec: Rated DC 12 V, 50 mA or less.

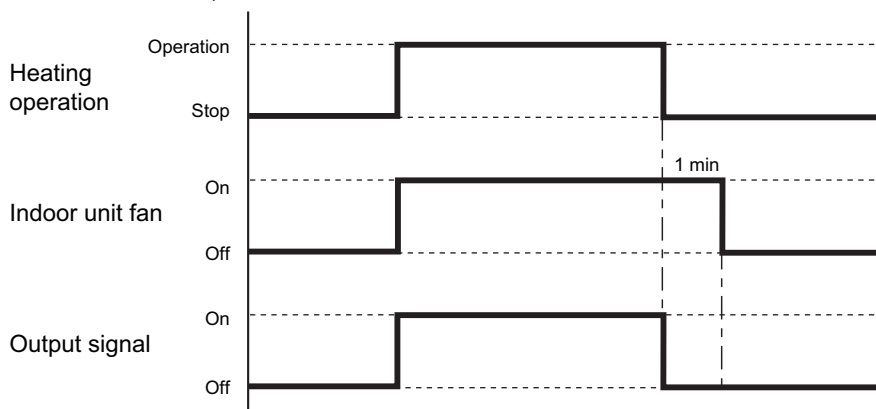

⚠ CAUTION

- Place an external heater between the indoor unit and the outlet.

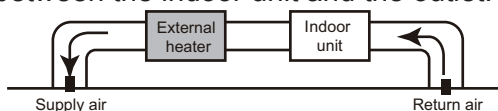

- Be sure to use delay control of the fan.

● Optional part

Model name	Exterior
UTD-ECS5A	Heater output wire 