

# 4. DIMENSIONS

## MODELS: AR\*G12LLTB, AR\*G14LLTB

(Unit : mm)

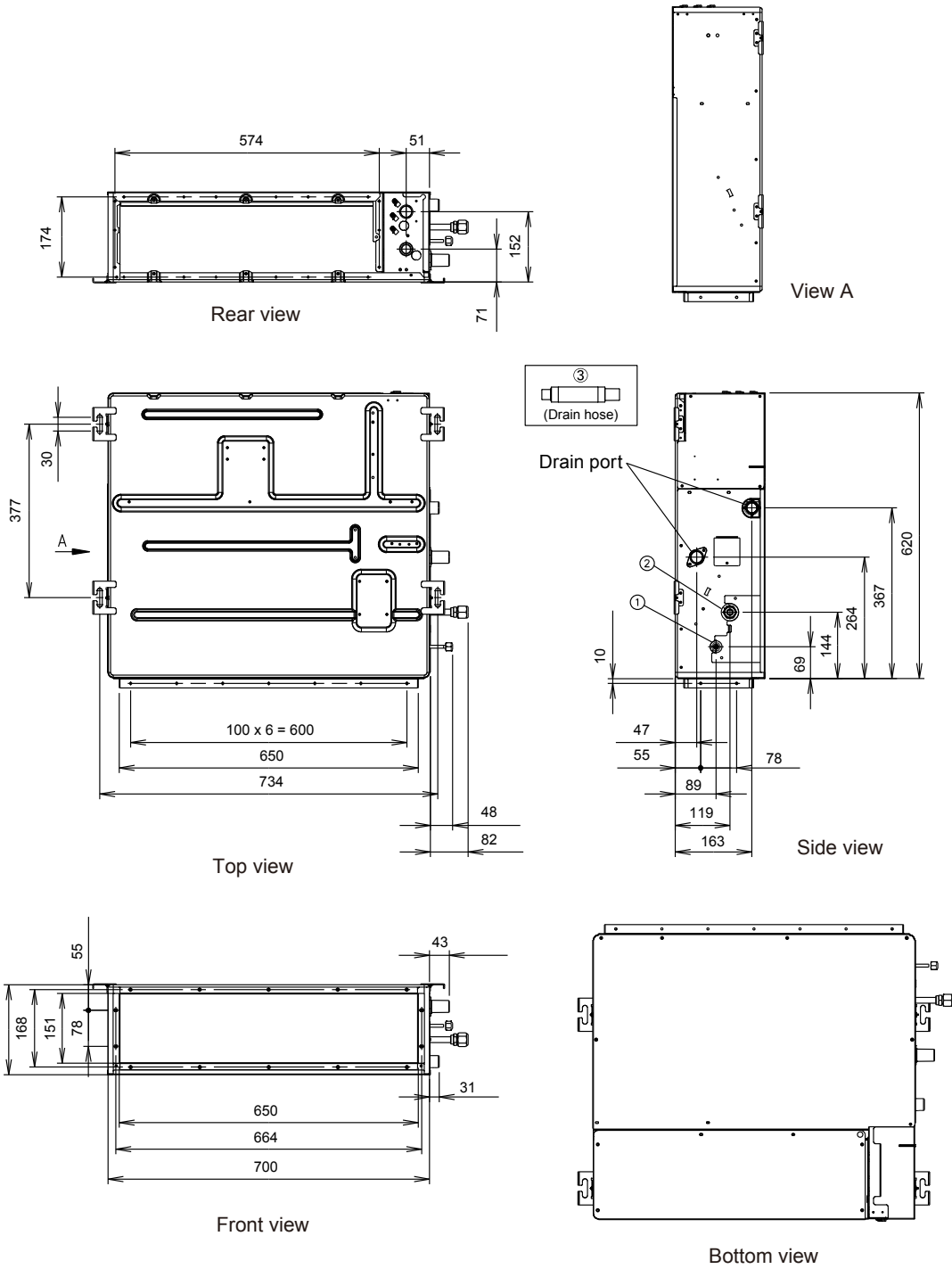

			AR*G12LL	AR*G14LL
①	Refrigerant pipe flare connection	Liquid	ø 6.35 mm (ø 1/4 in.)	
②		Gas	ø 9.52 mm (ø 3/8 in.)	ø 12.70 mm (ø 1/2 in.)
③	Drain hose connection	Drain hose	I.D. 25mm, O.D. 32mm (VP25)	

Unit : mm

# INSTALLATION PLACE

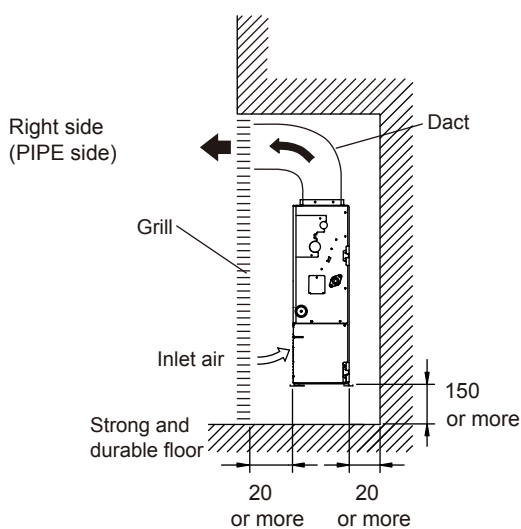
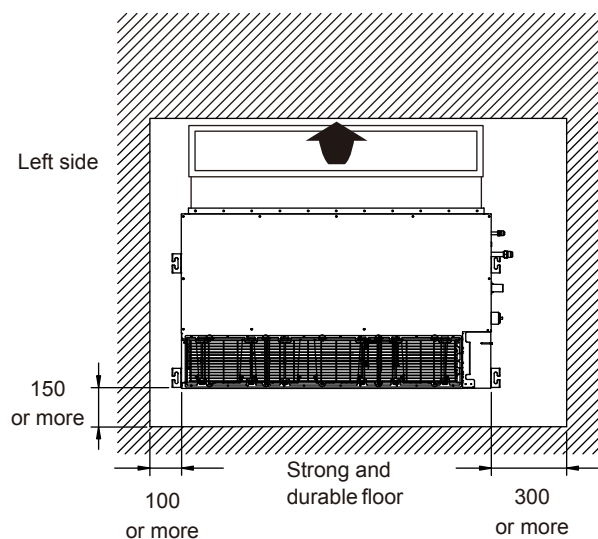
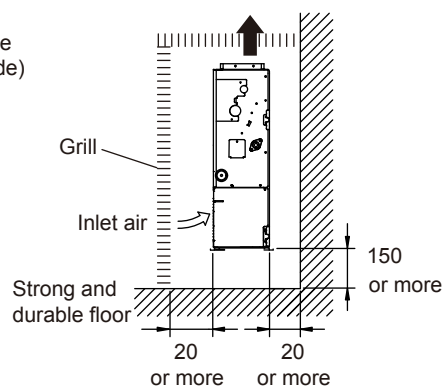
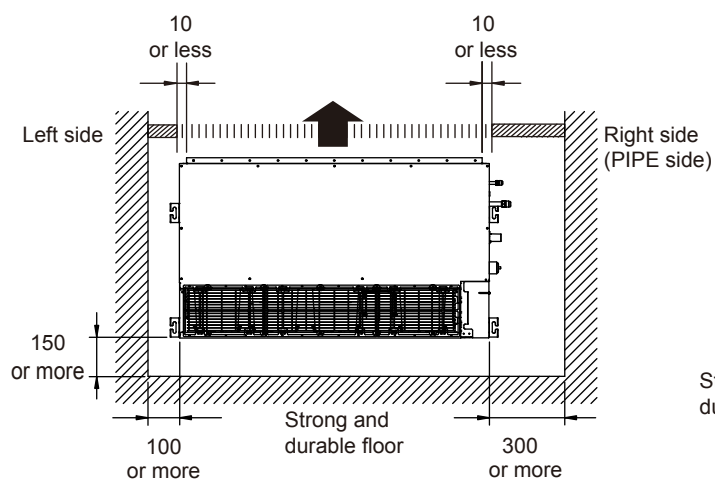
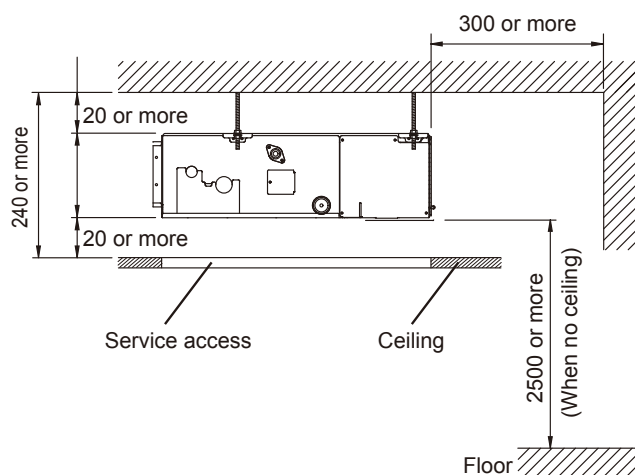
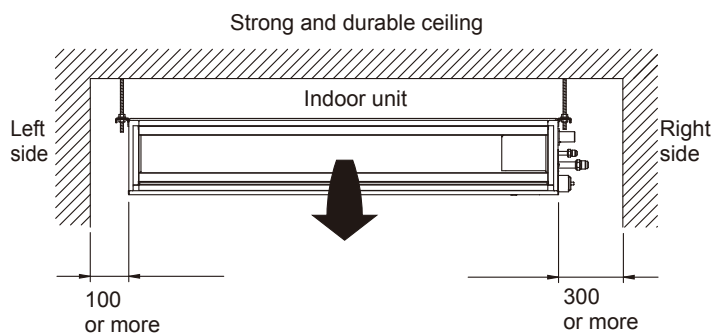

## MAINTENANCE SPACE

Unit : mm

Provide a service access for inspection purposes as shown below.

Do not place any wiring or illumination in the service space, as they will impede service.

