

## 4. DIMENSIONS

### ■ MODEL: AR\*G30LMLE, AR\*G36LMLE

(Unit : mm)

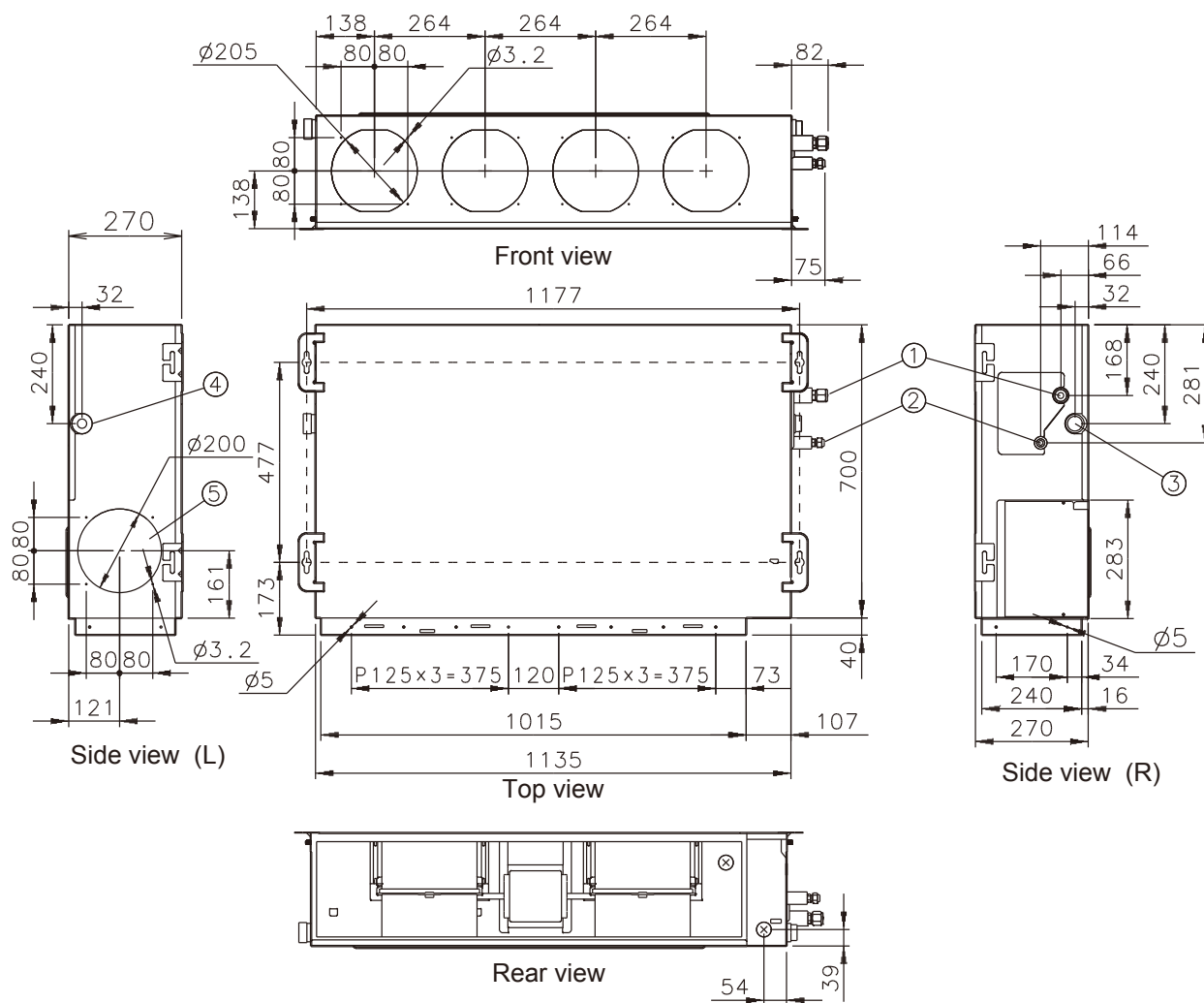

- ① Refrigerant piping flare connection (Gas)
- ② Refrigerant piping flare connection (Liquid)
- ③ Drain piping connection
- ④ Drain piping connection with cap.
- ⑤ Knock out hole for fresh air.

## ■ INSTALLATION PLACE

(Unit : mm)

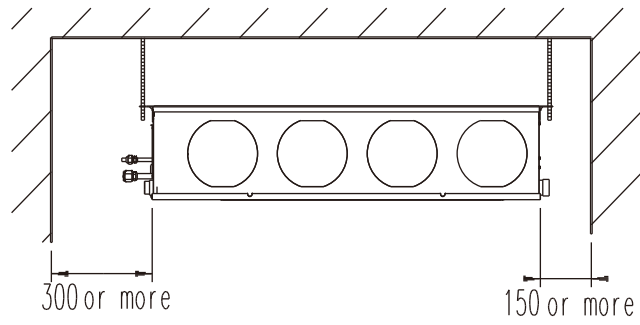

## ■ MAINTENANCE HOLE

It shall be possible to install and remove the control box.

It shall be possible to install and remove the control box, fan units and filter.

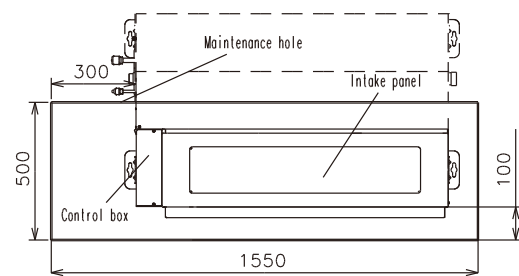
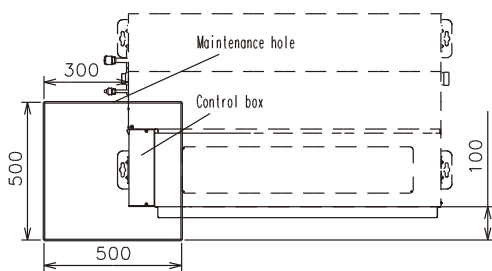

## ■ WHEN USING A SQUARE DUCT

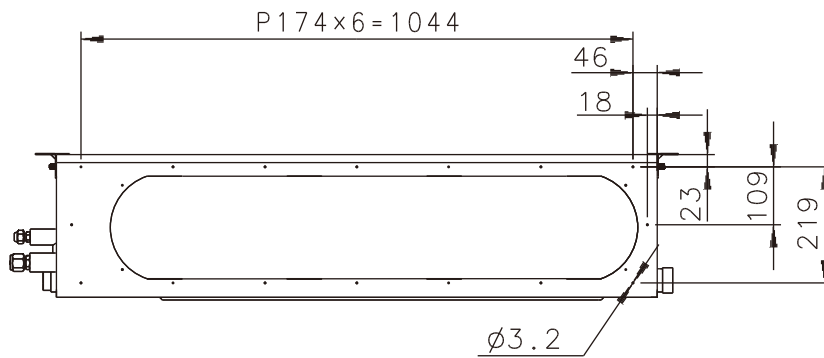

## ■ BOTTOM AIR INTAKE HOLE

