

**MODELS : ASYA18/ 24/ 30GBCH
ASHA18/ 24/ 30GBCH**

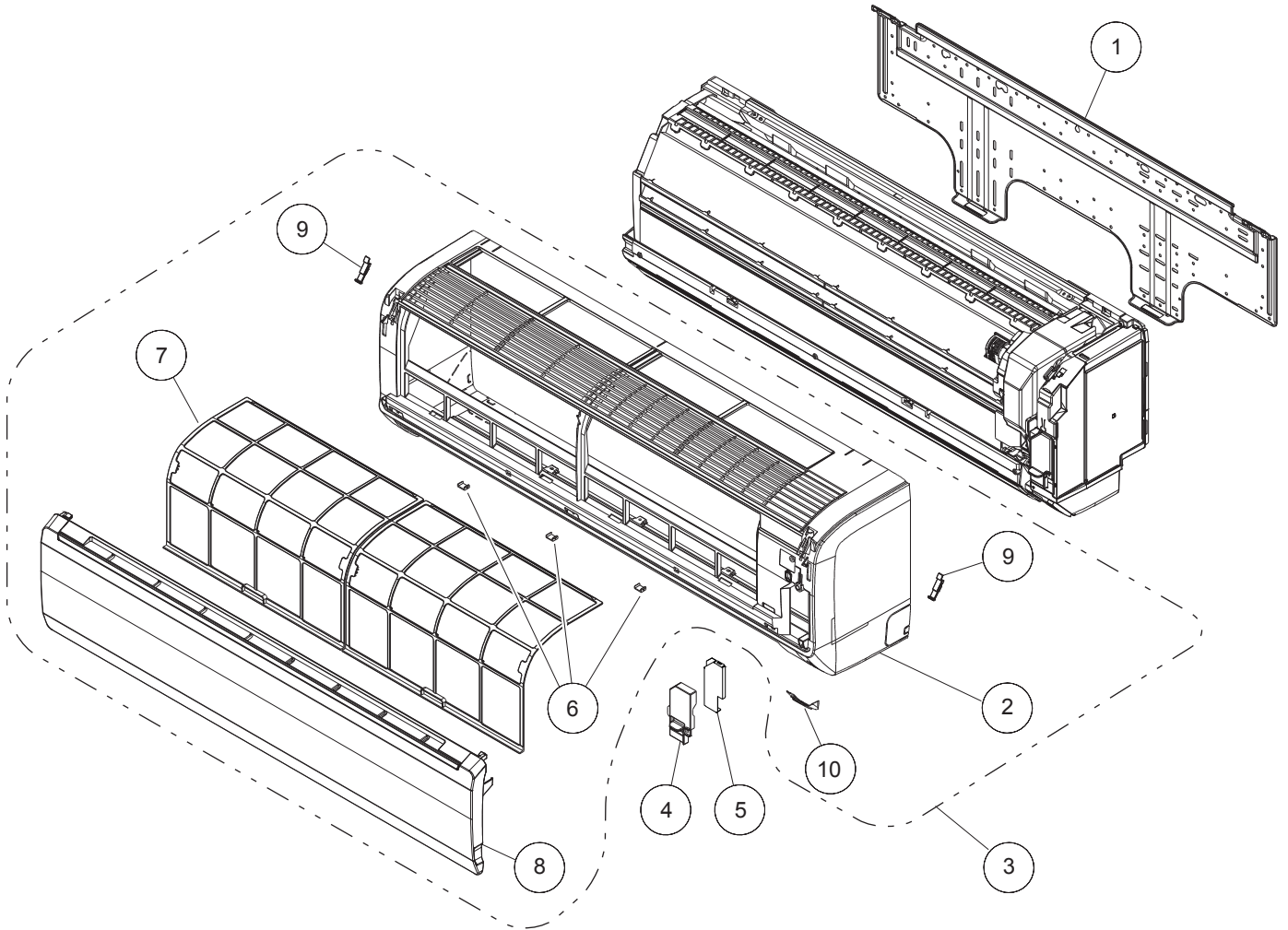

Ref No.	Description	Parts No.			Q'ty
		AS* A18GBCH	AS* A24GBCH	AS* A30GBCH	
1	BRACKET PANEL	9315023018	9315023018	9315023018	
2	FRONT PANEL	9314991073	9314991073	9314991073	
3	FRONT PANEL TOTAL ASSY (FUJITSU)	9315335364	9315335364	9315335364	
	FRONT PANEL TOTAL ASSY (GENERAL)	9315335371	9315335371	9315335371	
4	WIRE COVER	9380786009	9380786009	9380786009	
5	SHIELD D	9380787006	9380787006	9380787006	
6	CAP(SCREW)	9309002074	9309002074	9309002074	
7	AIR FILTER	9315014023	9315014023	9315014023	
8	INTAKE GRILLE ASSY (FUJITSU)	9385985193	9385985193	9385985193	
	INTAKE GRILLE ASSY (GENERAL)	9385985209	9385985209	9385985209	
9	CLAMPER GRILLE	9306755010	9306755010	9306755010	
10	RECEIVER WINDOW	9315010018	9315010018	9315010018	
	AIR CLEAN FILTER ASSY	9315212016	9315212016	9315212016	

**MODELS : ASYA18/ 24/ 30GBCH
ASHA18/ 24/ 30GBCH**

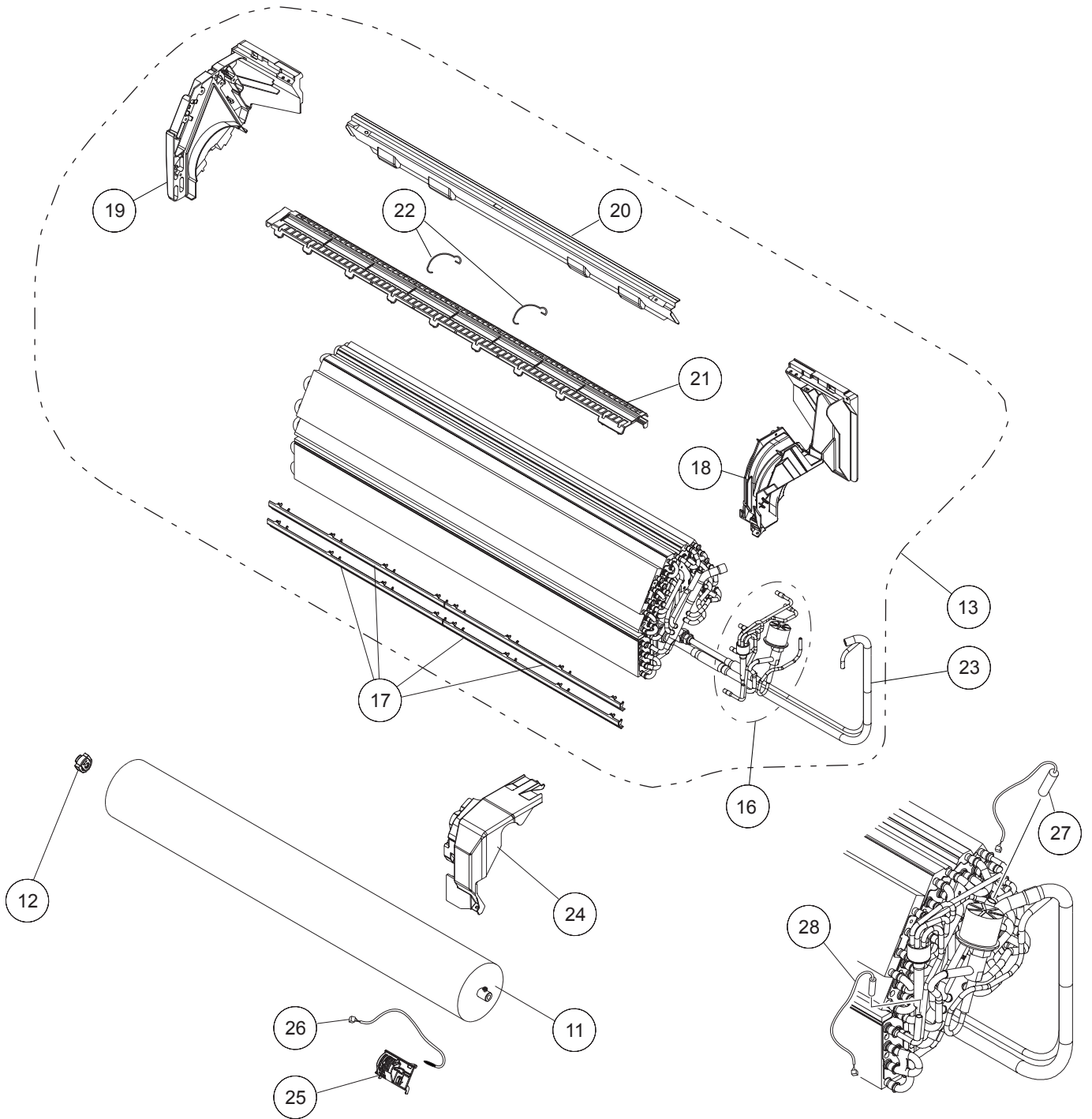

Ref No.	Description	Parts No.			Q'ty
		AS* A18GBCH	AS* A24GBCH	AS* A30GBCH	
11	CROSSFLOW FAN ASSY	9315024015	9315024015	9315024015	
12	BEARING C ASSY	9306628017	9306628017	9306628017	
13	EVAPORATOR TOTAL ASSY	9315338310	9315338204	9315338204	
16	EXPANSION VALVE SUB ASSY	9318601008	9318601008	9318601008	
17	WATER SEAL	9315251015	9315251015	9315251015	
18	EVAPORATOR HOLDER R	9379829007	9379829007	9379829007	
19	EVAPORATOR HOLDER L	9314995019	9314995019	9314995019	
20	REAR BRACKET	9315022011	9315022011	9315022011	
21	FILTER GUIDE	9315013040	9315013040	9315013040	
22	FILTER GUARD	9315411013	9315411013	9315411013	
23	CONNECTION PIPE ASSY	9315355089	9315355027	9315355027	
24	PIPE COVER	9379840019	9379840019	9379840019	
25	HOLDER(ROOM THERMISTOR)	9379930000	9379930000	9379930000	
26	THERMISTOR (ROOM)	9900585006	9900585006	9900585006	
27	THERMISTOR (PIPE-OUT)	9900498092	9900498092	9900498092	
28	THERMISTOR (PIPE-IN)	9900509071	9900509071	9900509071	

**MODELS : ASYA18/ 24/ 30GBCH
ASHA18/ 24/ 30GBCH**

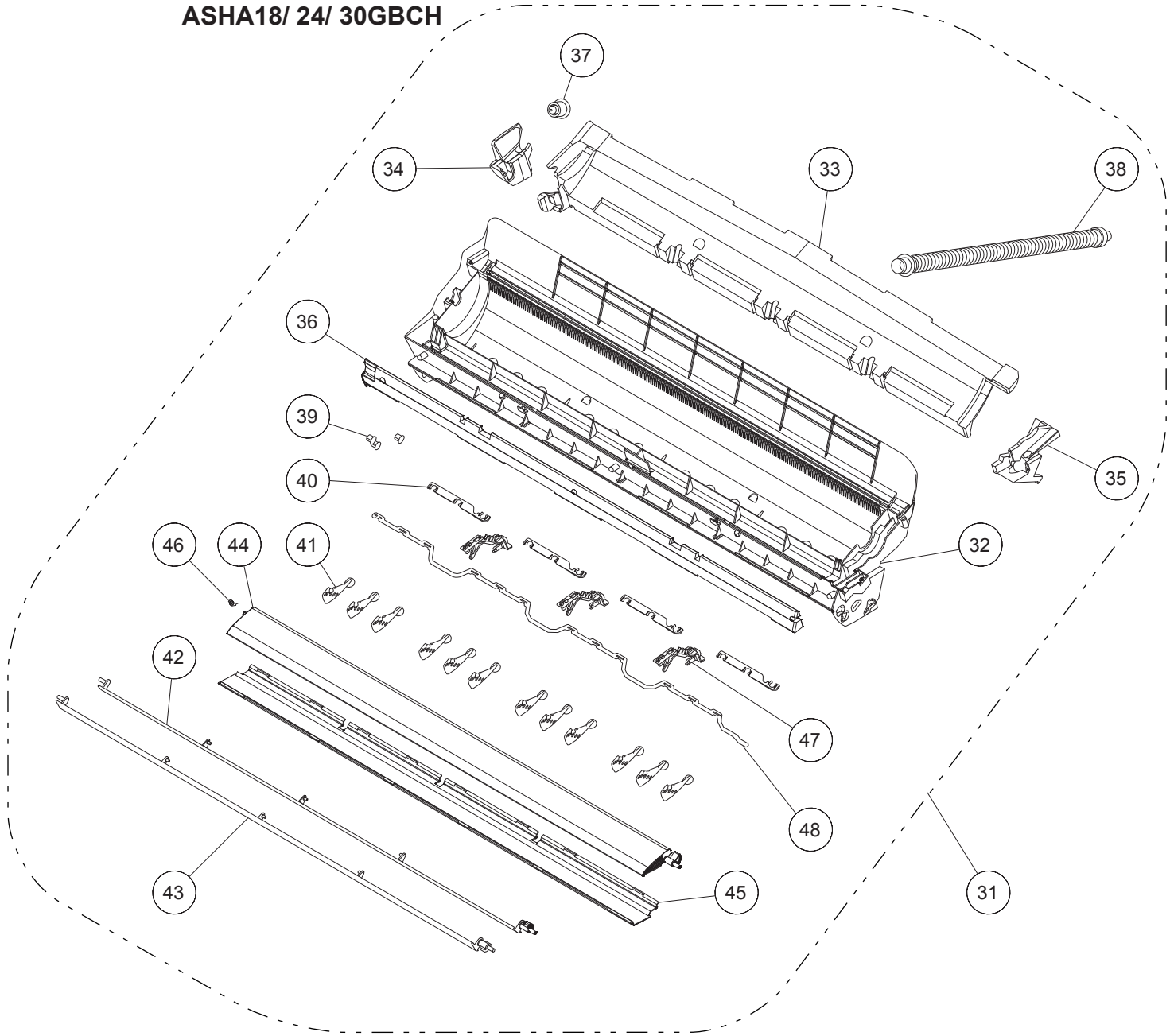

Ref No.	Description	Parts No.			Q'ty
		AS* A18GBCH	AS* A24GBCH	AS* A30GBCH	
31	CASING ASSY	9315331076	9315331076	9315331076	
32	CASING	9314993015	9314993015	9314993015	
33	CASING COVER B	9315016010	9315016010	9315016010	
34	CASING COVER L	9315017017	9315017017	9315017017	
35	CASING COVER R	9315018014	9315018014	9315018014	
36	CASING COVER F	9315019011	9315019011	9315019011	
37	DRAIN CAP	9367677009	9367677009	9367677009	
38	DRAIN HOSE ASSY	9315769015	9315769015	9315769015	
39	BUSH B	9312156016	9312156016	9312156016	
40	SPACER D	9315282019	9315282019	9315282019	
41	R AND L LOUVER	9311997016	9311997016	9311997016	
42	LOUVER U	9315000026	9315000026	9315000026	
43	LOUVER Z	9315001023	9315001023	9315001023	
44	DIFFUSER U	9315002020	9315002020	9315002020	
45	DIFFUSER Z	9315003027	9315003027	9315003027	
46	SPRING C	9314142017	9314142017	9314142017	
47	PILLER A	9315009012	9315009012	9315009012	
48	JOINT B	9315006011	9315006011	9315006011	
-	FAN GUARD	9305751051	9305751051	9305751051	
-	FAN GUARD HOLDER RIGHT	9315814012	9315814012	9315814012	
-	FAN GUARD HOLDER LEFT	9315815019	9315815019	9315815019	

**MODELS : ASYA18/ 24/ 30GBCH
ASHA18/ 24/ 30GBCH**

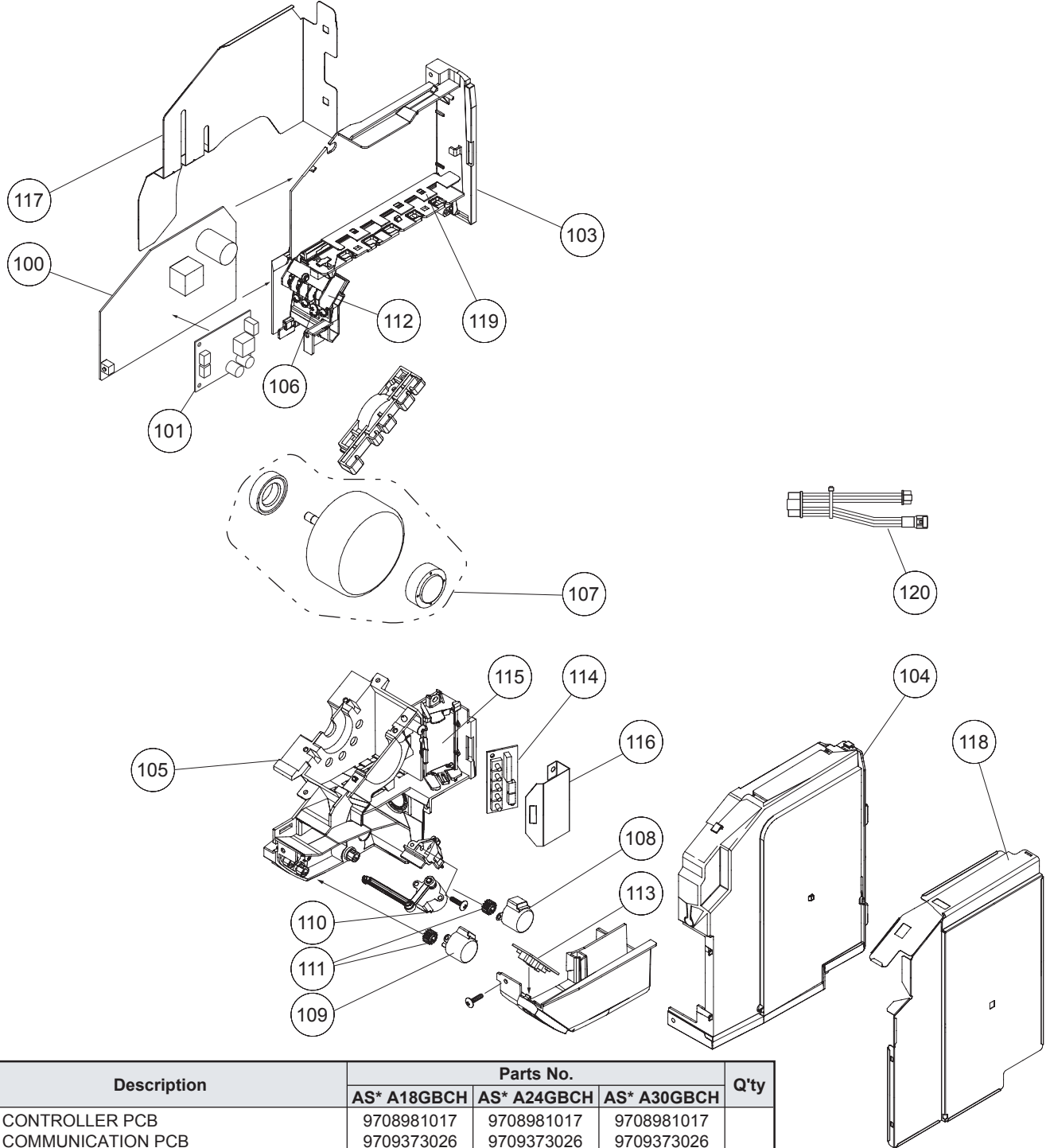

Ref No.	Description	Parts No.			Q'ty
		AS* A18GBCH	AS* A24GBCH	AS* A30GBCH	
100	CONTROLLER PCB	9708981017	9708981017	9708981017	
101	COMMUNICATION PCB	9709373026	9709373026	9709373026	
103	CONTROL BOX	9379830003	9379830003	9379830003	
104	CONTROL BOX COVER	9379831000	9379831000	9379831000	
105	MOTOR CASE	9314998034	9314998034	9314998034	
106	TERMINAL EARTH	9379835008	9379835008	9379835008	
107	FAN MOTOR ASSY	9602784004	9602784004	9602703012	
108	MOTOR STEP (RED)	9900384029	9900384029	9900384029	
109	MOTOR STEP (GREEN)	9900384036	9900384036	9900384036	
110	MOTOR STEP (BLUE)	9900139063	9900139063	9900139063	
111	GEAR A	9309994003	9309994003	9309994003	
112	TERMINAL	9900588007	9900588007	9900588007	
113	INDICATOR PCB ASSY	9707210040	9707210040	9707210040	
114	SWITCH PCB	9707732016	9707732016	9707732016	
115	SWITCH BOX	9379833004	9379833004	9379833004	
116	SWITCH BOX COVER	9379945004	9379945004	9379945004	
117	SHIELD A	9379836005	9379836005	9379836005	
118	SHIELD B	9379837002	9379837002	9379837002	
119	SHIELD C	9379838009	9379838009	9379838009	
120	THERMISTOR CONNECTION WIRE	9707854022	9707854022	9707854022	
-	FUSE 250V 3.15A	0600376062	0600376062	0600376062	
-	FUSE HOLDER	0500158072	0500158072	0500158072	