

2. Indoor unit parts list

2-1. Models: ASYH30KMTB and ASYH36KMTB

■ Exterior parts

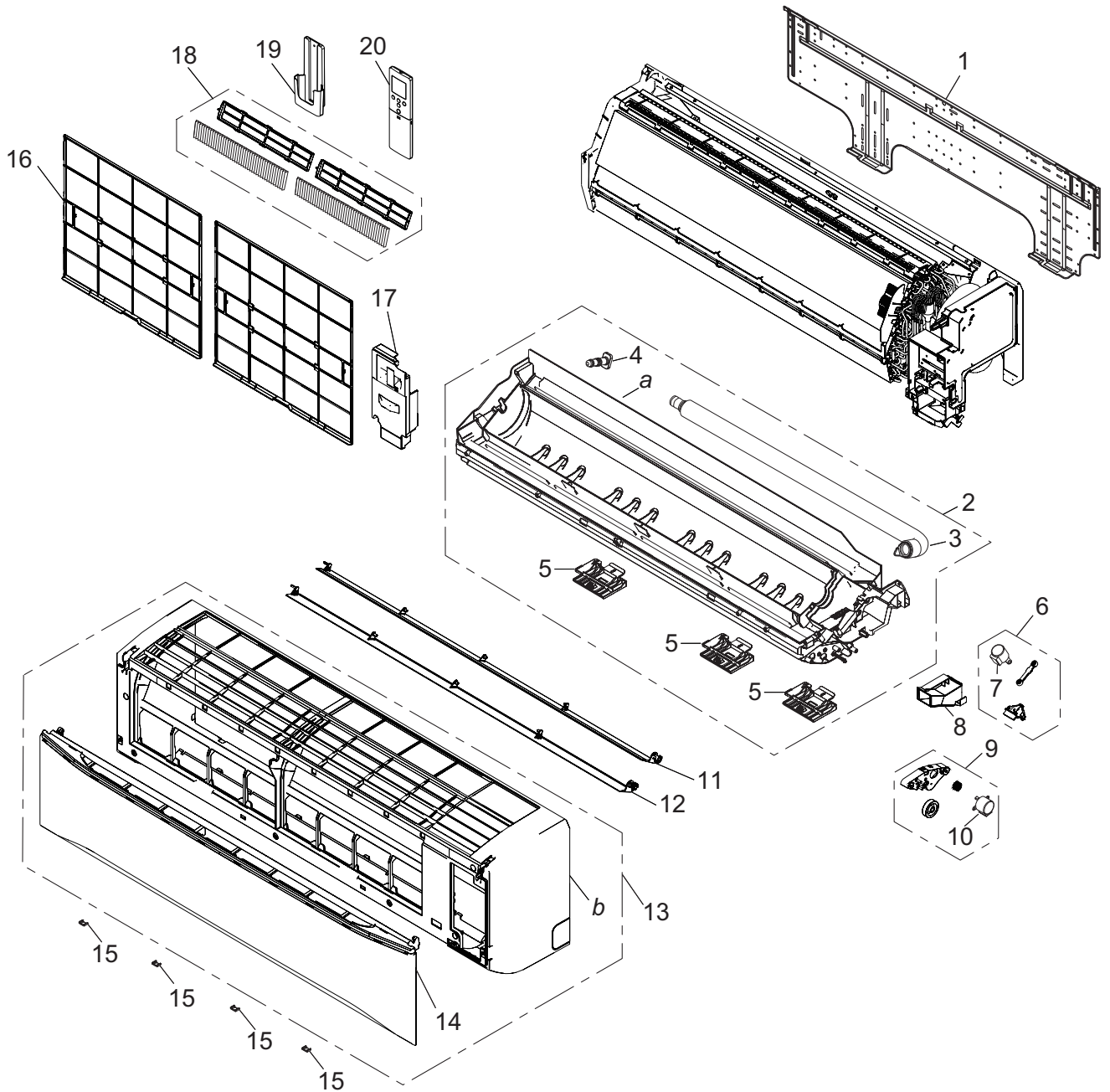

Item no.	Part no.	Part name	Service part
1	9386990004	Bracket panel	◆
2	9387060065	Casing assy	◆
3	9388540009	Drain hose assy	◆
4	9316177017	Drain cap	◆
5	9318743012	Pipe bracket	◆
6	9387063004	Link holder assy	◆
7	9900139186	Step motor	◆
8	9386997003	Cable guide	◆
9	9387062007	Gear cover assy	◆
10	9900384234	Step motor	◆
11	9386958011	Louver U	◆
12	9386959018	Louver Z	◆
13	9387072181	Front panel total assy	◆
14	9382114008	Intake grille assy	◆
15	9386986007	Screw cover	◆
16	9386960007	Air filter	◆
17	9387074017	Wire cover assy	◆
18	9315212016	Air clean filter assy	◆
19	9318912005	Remote controller holder	◆
20	9332438628	Remote controller assy	◆
<i>a</i>	—	Casing	—
<i>b</i>	—	Front panel	—

Evaporator and control

TECHNICAL DATA
AND PARTS LIST

TECHNICAL DATA
AND PARTS LIST

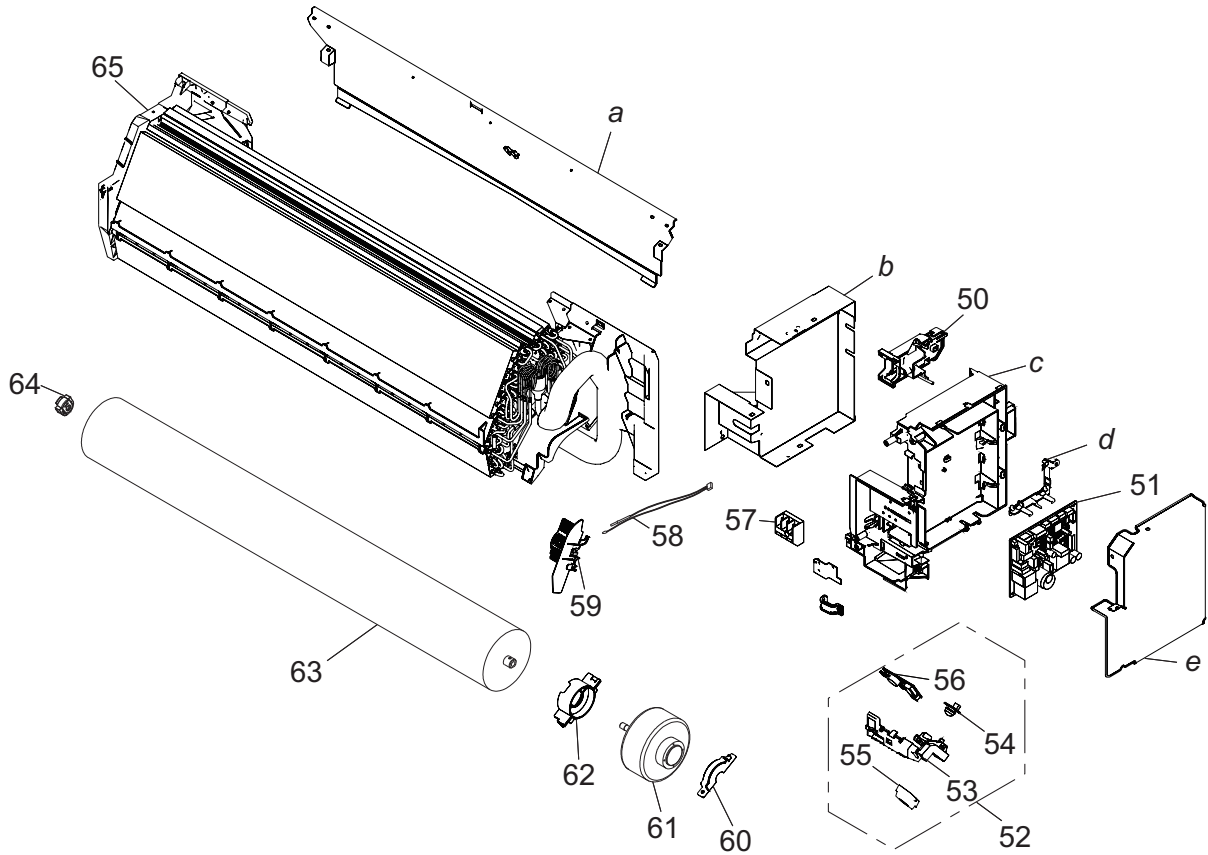

Item no.	Part no.	Part name	Service part
50	9383765063	WLAN adapter holder assy	◆
51	9711732439	Main PCB (For 30 model)	◆
	9711732446	Main PCB (For 36 model)	◆
52	9711146045	Display assy	◆
53	9387249019	Display case assy	◆
54	9317755061	Pyroelectric sensor	◆
55	9382134006	Front panel cover B assy	◆
56	9711147035	Indicator PCB	◆
57	9901013010	Terminal	◆
58	9900627027	Thermistor assy	◆
59	9386988001	Room thermistor holder	◆
60	9316568006	Motor cover	◆
61	9603839017	DC fan motor	◆
62	9316601000	Motor cover	◆
63	9387055009	Crossflow fan assy	◆
64	9306628017	Bearing C assy	◆
65	9387064070	Evaporator total assy	◆
66	9901010071	Wire with connector (USB adapter connection)	◆
67	9709626023	Wire with connector (CN10 on Main PCB—Pyroelectric sensor)	◆
<i>a</i>	—	Rear panel	—
<i>b</i>	—	Box shield assy	—
<i>c</i>	—	Control box	—
<i>d</i>	—	PCB holder A	—
<i>e</i>	—	Control cover	—