

AUXB004GLEH
AUXB007GLEH
AUXB009GLEH
AUXB012GLEH
AUXB014GLEH
AUXB018GLEH
AUXB024GLEH

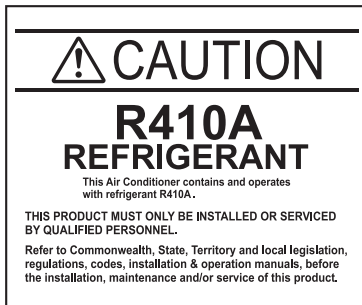

Refer to the rating label for the serial number, manufactured year and month.

FUJITSU GENERAL LIMITED

INSTALLATION MANUAL

INDOOR UNIT (Cassette Type)

For authorized service personnel only.

English

INSTALLATIONSANLEITUNG

INNENGERÄT (Kassettyp)

Nur für autorisiertes Fachpersonal.

Deutsch

MANUEL D'INSTALLATION

UNITÉ INTÉRIEURE (type cassette)

Pour le personnel agréé uniquement.

Français

MANUAL DE INSTALACIÓN

UNIDAD INTERIOR (Tipo casete)

Únicamente para personal de servicio autorizado.

Español

MANUALE DI INSTALLAZIONE

UNITÀ INTERNA (tipo a cassetta)

A uso esclusivo del personale tecnico autorizzato.

Italiano

ΕΓΧΕΙΡΙΔΙΟ ΕΓΚΑΤΑΣΤΑΣΗΣ

ΕΣΩΤΕΡΙΚΗ ΜΟΝΑΔΑ (Τύπος Κασέτας)

Μόνο για εξουσιοδοτημένο τεχνικό προσωπικό.

Ελληνικά

MANUAL DE INSTALAÇÃO

UNIDADE INTERIOR (Tipo Cassete)

Apenas para técnicos autorizados.

Português

РУКОВОДСТВО ПО УСТАНОВКЕ

ВНУТРЕННИЙ МОДУЛЬ (кассетного типа)

Только для авторизованного обслуживающего персонала.

Русский

MONTAJ KILAVUZU

İÇ ÜNİTE (Kaset Tipi)

Yalnızca yetkili servis personeli için.

Türkçe

MADE IN P.R.C.



[Original instructions]

PART No. 9371022635

INSTALLATION MANUAL

PART No. 9371022635
VRF system indoor unit (Cassette type)

Contents

1. SAFETY PRECAUTIONS.....	1
2. ABOUT THIS PRODUCT.....	1
2.1. Precautions for using the R410A refrigerant.....	1
2.2. Special tool for R410A.....	1
2.3. Accessories.....	1
2.4. Optional parts.....	2
3. INSTALLATION WORK.....	2
3.1. Selecting an installation location.....	2
3.2. Installation dimensions.....	2
3.3. Discharge direction setting.....	3
3.4. Installing the unit.....	3
4. PIPE INSTALLATION.....	3
4.1. Selecting the pipe material.....	3
4.2. Pipe requirement.....	4
4.3. Flare connection (pipe connection).....	4
4.4. Installing heat insulation.....	4
5. INSTALLING DRAIN PIPES.....	4
6. ELECTRICAL WIRING.....	5
6.1. Electrical requirement.....	5
6.2. Wiring method.....	6
6.3. Unit wiring.....	6
6.4. Connection of wiring.....	7
6.5. Optional parts wiring.....	7
6.6. External input and external output (Optional parts).....	8
7. FIELD SETTING.....	9
7.1. Setting the address.....	9
7.2. Custom code setting.....	10
7.3. Function setting.....	10
8. CASSETTE GRILLE INSTALLATION.....	11
8.1. Remove the intake grille.....	11
8.2. Install cassette grille to indoor unit.....	11
8.3. Attach the intake grille.....	12
9. TEST RUN.....	12
9.1. Test run using Outdoor unit (PCB).....	12
9.2. Test run using Remote Controller.....	12
10. CHECK LIST.....	12
11. ERROR CODES.....	12

1. SAFETY PRECAUTIONS

- Be sure to read this Manual thoroughly before installation.
- The warnings and precautions indicated in this Manual contain important information pertaining to your safety. Be sure to observe them.
- Hand this Manual, together with the Operating Manual to the customer.
- Request the customer to keep them on hand for future use, such as for relocating or repairing the unit.

 WARNING	This mark indicates procedures which, if improperly performed, might lead to the death or serious injury of the user.
Request your dealer or a professional installer to install the unit in accordance with this Manual. An improperly installed unit can cause serious accidents such as water leakage, electric shock, or fire. If the unit is installed in disregard of the instructions in the Installation Manual, it will void the manufacturer's warranty.	
Do not turn ON the power until all work has been completed. Turning ON the power before the work is completed can cause serious accidents such as electric shock or fire.	
If refrigerant leaks while work is being carried out, ventilate the area. If the refrigerant comes in contact with a flame, it produces a toxic gas.	
Installation work must be performed in accordance with national wiring standards by authorized personnel only.	
Except for EMERGENCY, never turn off main as well as sub breaker of the indoor units during operation. It will cause compressor failure as well as water leakage. First, stop the indoor unit by operating the control unit, converter or external input device and then cut the breaker. Make sure to operate through the control unit, converter or external input device. When the breaker is designed, locate it at a place where the users cannot start and stop in the daily work.	

 CAUTION	This mark indicates procedures which, if improperly performed, might possibly result in personal harm to the user, or damage to property.
Read carefully all security information before use or install the air conditioner.	
Do not attempt to install the air conditioner or a part of the air conditioner by yourself.	
This unit must be installed by qualified personnel with a capacity certificate for handling refrigerant fluids. Refer to regulation and laws in use on installation place.	
The installation must be carried out in compliance with regulations in force in the place of installation and the installation instructions of the manufacturer.	
This unit is part of a set constituting an air conditioner. It must not be installed alone or with non-authorized by the manufacturer.	
Always use a separate power supply line protected by a circuit breaker operating on all wires with a distance between contact of 3mm for this unit.	
The unit must be correctly earthed (grounded) and the supply line must be equipped with a differential breaker in order to protect the persons.	
The units are not explosion proof and therefore should not be installed in explosive atmosphere.	
Never touch electrical components immediately after the power supply has been turned off. Electric shock may occur. After turning off the power, always wait 5 minutes before touching electrical components.	
This unit contains no user-serviceable parts. Always consult authorized service personnel to repairs.	
When moving, consult authorized service personnel for disconnection and installation of the unit.	

2. ABOUT THIS PRODUCT

2.1. Precautions for using the R410A refrigerant

 WARNING	Do not introduce any substance other than the prescribed refrigerant into the refrigeration cycle. If air enters the refrigeration cycle, the pressure in the refrigeration cycle will become abnormally high and cause the piping to rupture.
If there is a refrigerant leakage, make sure that it does not exceed the concentration limit. If a refrigerant leakage exceeds the concentration limit, it can lead to accidents such as oxygen starvation.	
Do not touch refrigerant that has leaked from the refrigerant pipe connections or other area. Touching the refrigerant directly can cause frostbite.	
If a refrigerant leakage occurs during operation, immediately vacate the premises and thoroughly ventilate the area. If the refrigerant comes in contact with a flame, it produces a toxic gas.	

2.2. Special tool for R410A









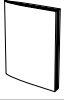

 WARNING	To install a unit that uses the R410A refrigerant, use dedicated tools and piping materials that have been manufactured specifically for R410A use. Because the pressure of the R410A refrigerant is approximately 1.6 times higher than the R22, failure to use dedicated piping material or improper installation can cause rupture or injury. Furthermore, it can cause serious accidents such as water leakage, electric shock, or fire.
--	--

Tool name	Contents of change
Gauge manifold	Pressure is huge and cannot be measured with a conventional (R22) gauge. To prevent erroneous mixing of other refrigerants, the diameter of each port has been changed. It is recommended to use a gauge manifold with a high pressure display range -0.1 to 5.3 MPa and a low pressure display range -0.1 to 3.8 MPa.
Charging hose	To increase pressure resistance, the hose material and base size were changed.
Vacuum pump	A conventional (R22) vacuum pump can be used by installing a vacuum pump adapter. Be sure that the pump oil does not backflow into the system. Use one capable for vacuum suction of -100.7 kPa (5 Torr, -755 mmHg).
Gas leakage detector	Special gas leakage detector for HFC refrigerant R410A.

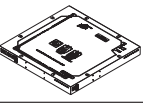
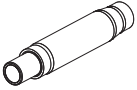

2.3. Accessories

 WARNING	For installation purposes, be sure to use the parts supplied by the manufacturer or other prescribed parts. The use of non-prescribed parts can cause serious accidents such as the unit to fall, water leakage, electric shock, or fire.
The following installation parts are furnished. Use them as required.	
Keep the Installation Manual in a safe place and do not discard any other accessories until the installation work has been completed.	

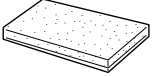
Do not discard any accessories needed for installation until the installation work has been completed.

Name and Shape	Q'ty	Application
Operating manual 	1	
Installation manual 	1	(This book)
Operating Manual (CD-ROM) 	1	
Cable tie (Large) 	4	For fixing the connection pipe (Large and Small)
Cable tie (Medium) 	2	For transmission and remote controller cable binding.
Coupler heat insulation (Small) 	1	For indoor side pipe joint (Small)
Coupler heat insulation (Large) 	1	For indoor side pipe joint (Large)
Special nut A (Large flange) 	4	For installing indoor unit
Special nut B (Small flange) 	4	For installing indoor unit
Template (Carton top) 	1	For ceiling openings cutting Also used as packing
Drain hose 	1	For installing drain pipe VP25 (O.D.32, I.D.25)
Hose band 	1	For installing drain hose
Drain hose insulation 	1	For installing drain hose

Cassette grille accessories

Name and Shape	Q'ty	Application
Connector cover 	1	For covering connector
Tapping screw (M5 × 12mm) 	4	For mounting cassette grille
Tapping screw (M4 × 12mm) 	1	For mounting connector cover

2.4. Optional parts

Description	Model	Application
External connect kit	UTY-XWZXZC	For output function (Output terminal / CNB01)
	UTY-XWZXZB	For control input function (Apply voltage terminal / CNA01)
	UTY-XWZXZD	For control input function (Dry contact terminal / CNA02)
	UTY-XWZXZ7	For forced thermostat off function (Apply voltage terminal / CNA03)
	UTY-XWZXZE	For forced thermostat off function (Dry contact terminal / CNA04)
Air outlet shutter plate	UTR-YDZB	Install the plate at outlet when carrying out 3-way direction operation.
Insulation kit for high humidity	UTZ-KXGC	Install when the condition under the roof is over 80% in humidity and over 30°C in temperature.

Description	Model	Application
Fresh air intake kit	UTZ-VXAA	To take fresh air.
Wireless LAN adapter	UTY-TFSXZ*	For wireless LAN control.
External power supply unit	UTZ-GXXA	Supply power to the indoor unit PCB when the indoor unit is turned off to prevent errors.

3. INSTALLATION WORK

Correct initial installation location is important because it is difficult to move unit after it is installed.

3.1. Selecting an installation location

⚠ WARNING

Select installation locations that can properly support the weight of the indoor. Install the units securely so that they do not topple or fall.

⚠ CAUTION

Do not install the unit in the following areas:

- Area with high salt content, such as at the seaside.
- It will deteriorate metal parts, causing the parts to fail or the unit to leak water.
- Area filled with mineral oil or containing a large amount of splashed oil or steam, such as a kitchen.
- It will deteriorate plastic parts, causing the parts to fail or the unit to leak water.
- Area that generates substances that adversely affect the equipment, such as sulfuric gas, chlorine gas, acid, or alkali.
- It will cause the copper pipes and brazed joints to corrode, which can cause refrigerant leakage.
- Area that can cause combustible gas to leak, contains suspended carbon fibers or flammable dust, or volatile inflammables such as paint thinner or gasoline.
- If gas leaks and settles around the unit, it can cause a fire.
- Area where animals may urinate on the unit or ammonia may be generated.

Do not use the unit for special purposes, such as storing food, raising animals, growing plants, or preserving precision devices or art objects. It can degrade the quality of the preserved or stored objects.

Do not install where there is the danger of combustible gas leakage.

Do not install the unit near a source of heat, steam, or flammable gas.

Install the unit where drainage does not cause any trouble.

Install the indoor unit, power supply cable, transmission cable, and remote controller cable at least 1 m away from a television or radio receivers. The purpose of this is to prevent TV reception interference or radio noise. (Even if they are installed more than 1 m apart, you could still receive noise under some signal conditions.)

If children under 10 years old may approach the unit, take preventive measures so that they cannot reach the unit.

Use the "Insulation kit for high humidity" (option), when the condition under the roof is over 80% in humidity and over 30°C in temperature. Otherwise, there is a risk of condensation on the ceiling.

Decide the mounting position with the customer as follows:

- (1) Install the indoor unit on a place having a sufficient strength so that it withstands against the weight of the indoor unit.
- (2) The inlet and outlet ports should not be obstructed; the air should be able to blow all over the room.
- (3) Leave the space required to service the air conditioner.
- (4) A place from where the air can be distributed evenly throughout the room by the unit.
- (5) Install the unit where connection to the outdoor unit (or RB unit) is easy.
- (6) Install the unit where the connection pipe can be easily installed.
- (7) Install the unit where the drain pipe can be easily installed.
- (8) Install the unit where noise and vibrations are not amplified.
- (9) Take servicing, etc., into consideration and leave the spaces. Also install the unit where the filter can be removed.

3.2. Installation dimensions

- Leave the space specified in Fig. A so that the air from the blower will cover the entire room.
- Install the indoor unit on a place having a sufficient strength so that it withstands against the weight of the indoor unit.
- A place from where drainage can be extracted outdoors easily.

⚠ WARNING

Never install in a room where there is the potential of leaking flammable gas. A spark could ignite the gas and cause an explosion or fire.

Avoid installing in a location with high temperature.

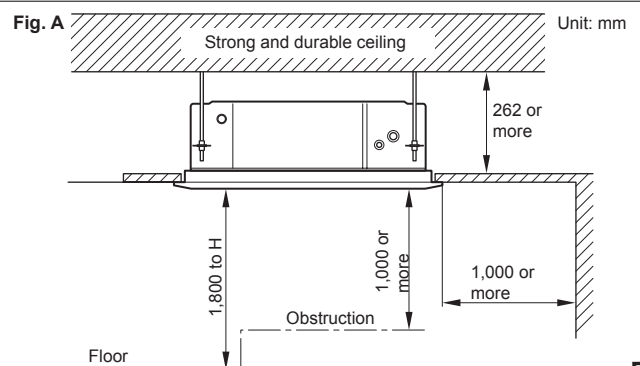

4.2. Pipe requirement

⚠ CAUTION

Refer to the installation manual for the outdoor unit for description of allowable pipe length and height difference.

Use pipe with water-resistant heat insulation.

⚠ CAUTION

Install heat insulation around both the gas and liquid pipes. Failure to do so may cause water leaks.

Use heat insulation with heat resistance above 120 °C. (Reverse cycle model only)
In addition, if the humidity level at the installation location of the refrigerant piping is expected to exceed 70 %, install heat insulation around the refrigerant piping. If the expected humidity level is 70 to 80 %, use heat insulation that is 15 mm or thicker and if the expected humidity exceeds 80 %, use heat insulation that is 20 mm or thicker. If heat insulation is used that is not as thick as specified, condensation may form on the surface of the insulation. In addition, use heat insulation with heat conductivity of 0.045 W/(m·K) or less (at 20 °C).

4.3. Flare connection (pipe connection)

⚠ WARNING

Tighten the flare nuts with a torque wrench using the specified tightening method. Otherwise, the flare nuts could break after a prolonged period, causing refrigerant to leak and generate hazardous gas if the refrigerant comes into contact with a flame.

4.3.1. Flaring

Use special flare tool exclusive for R410A.

- Cut the connection pipe to the necessary length with a pipe cutter.
- Hold the pipe downward so that cuttings will not enter the pipe and remove any burrs.
- Insert the flare nut (always use the flare nut attached to the indoor and outdoor units (or RB unit) respectively) onto the pipe and perform the flare processing with a flare tool. Use the special R410A flare tool. Leakage of refrigerant may result if other flare nuts are used.
- Protect the pipes by pinching them or with tape to prevent dust, dirt, or water from entering the pipes.

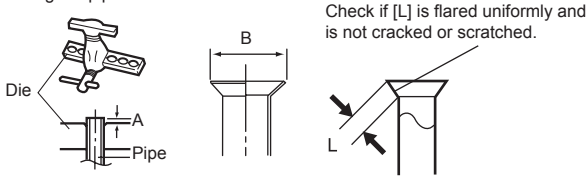

Pipe outside diameter [mm (in)]	Dimension A [mm]	Dimension B _{0.4} [mm]
	Flare tool for R410A, clutch type	
6.35 (1/4)	0 to 0.5	9.1
9.52 (3/8)		13.2
12.70 (1/2)		16.6
15.88 (5/8)		19.7
19.05 (3/4)		24.0

When using conventional (R22) flare tools to flare R410A pipes, the dimension A should be approximately 0.5 mm more than indicated in the table (for flaring with R410A flare tools) to achieve the specified flaring. Use a thickness gauge to measure the dimension A. It is recommended that a R410A flaring tool is used.

Width across flats	Pipe outside diameter [mm (in)]	Width across flats of Flare nut [mm]
	6.35 (1/4)	17
	9.52 (3/8)	22
	12.70 (1/2)	26
	15.88 (5/8)	29
	19.05 (3/4)	36

4.3.2. Bending pipes

- If pipes are shaped by hand, be careful not to collapse them.
- Do not bend the pipes in an angle more than 90°.
- When pipes are repeatedly bent or stretched, the material will harden, making it difficult to bend or stretch them anymore.
- Do not bend or stretch the pipes more than 3 times.

⚠ CAUTION

To prevent breaking of the pipe, avoid sharp bends.

If the pipe is bent repeatedly at the same place, it will break.

4.3.3. Pipe connection

When the flare nut is tightened properly by your hand, hold the body side coupling with a separate spanner, then tighten with a torque wrench. (See the table below for the flare nut tightening torques.)

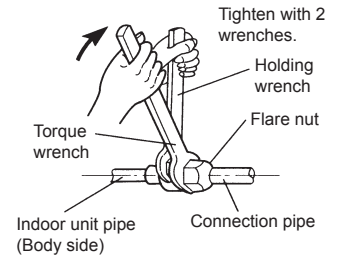

⚠ CAUTION

Hold the torque wrench at its grip, keeping it at a right angle with the pipe, in order to tighten the flare nut correctly.

Flare nut [mm (in)]	Tightening torque [N·m (kgf·cm)]
6.35 (1/4) dia.	16 to 18 (160 to 180)
9.52 (3/8) dia.	32 to 42 (320 to 420)
12.70 (1/2) dia.	49 to 61 (490 to 610)
15.88 (5/8) dia.	63 to 75 (630 to 750)
19.05 (3/4) dia.	90 to 110 (900 to 1,100)

4.4. Installing heat insulation

Install the heat insulation material after performing a refrigerant leak check (see the Installation Manual for the outdoor unit for details).

Coupler heat insulation

- Insulate by the coupler heat insulation (Accessories) around the gas pipe and liquid pipe of indoor side.
- After installing the coupler heat insulation, wrap both end with vinyl tape so that there is no gap.
- After affixing the coupler heat insulation, secure it with 2 cable ties (large), one on each end of the insulation.
- Make sure that the cable ties overlap the heat insulation pipe.

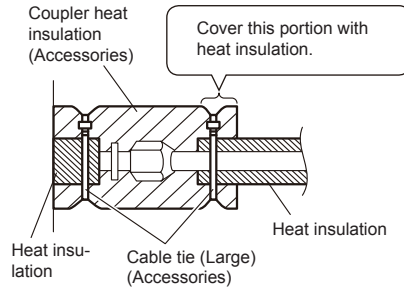

⚠ CAUTION

After checking for gas leaks (refer to the Installation Manual of the outdoor unit), perform this section.

Install heat insulation around both the large (gas) and small (liquid) pipes. Failure to do so may cause water leaks.

5. INSTALLING DRAIN PIPES

⚠ WARNING

Do not insert the drain piping into the sewer where sulfurous gas occurs. (Heat exchange erosion may occur)

Insulate the parts properly so that water will not drip from the connection parts.

Check for proper drainage after the construction by using the visible portion of transparent drain port and the drain piping final outlet on the body.

⚠ CAUTION

Do not apply adhesive agent on the drain port of the body. (Use the attached drain hose and connect the drain piping)

- Install the drain pipe with downward gradient (1/100 to 1/50) and so there are no rises or traps in the pipe. Unsmooth draining caused by accumulated water flow in the pipe may cause clogged drain.
- Use general hard polyvinyl chloride pipe (VP25) [outside diameter 32 mm].
- When the pipe is long, install supporters.
- Do not perform air bleeding. Drainage may be blown out.
- Always heat insulate the indoor side of the drain pipe.
- If it is impossible to have sufficient gradient of pipe, perform drain lift-up.

Drain pipe size

VP25 (O.D. 32 mm)

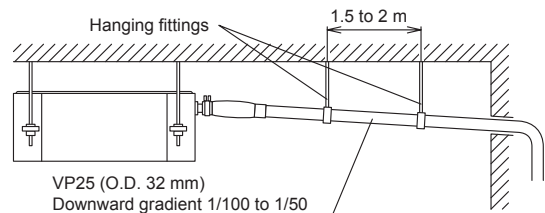

PROHIBITED:

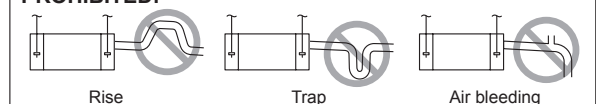

When lifting up drain:

- Height of inclined pipe should be less than 700 mm from the ceiling. A rise dimension over this range will cause leakage.
- Lift up the pipe vertically at the position of 300 mm or less from the unit.

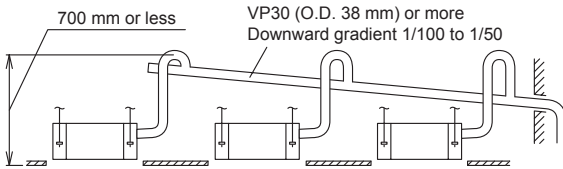
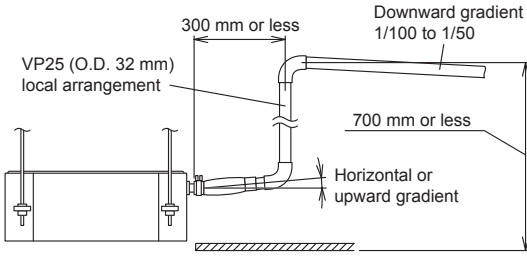

Working procedure

- (1) Install the attached drain hose to the drain port of the body. Install the hose band from the top of the hose within the graphic display area.
- (2) Use vinyl adhesive agent to glue the drain piping (PVC pipe VP25) which is prepared on site or elbow socket.
- (3) (Apply color adhesive agent evenly until the gauge line and seal)
- (4) Check the drainage. (See separate diagram)
- (5) Install the heat insulation.
- (6) Use the attached heat insulation to insulate the drain port and band parts of the body.

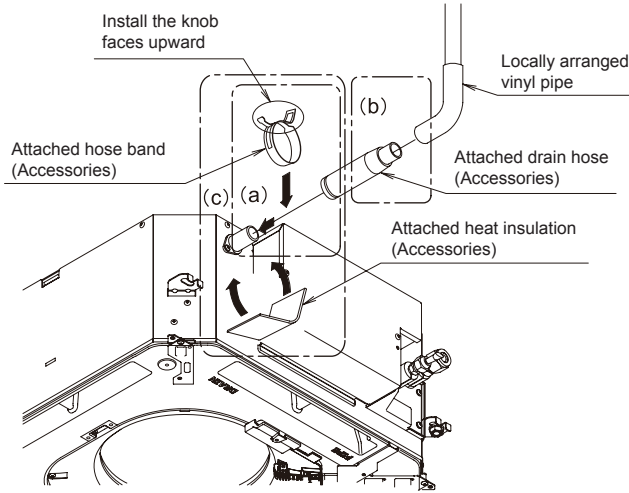

(a) Top view

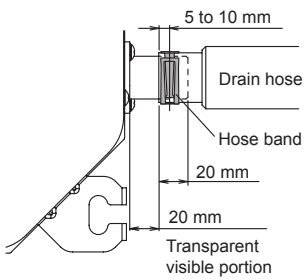

(b) Side view

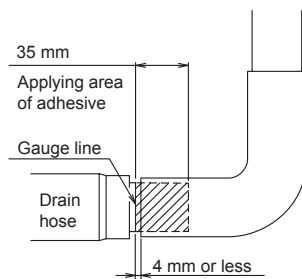

(c) Hose opening view

Wind the attached heat insulation around the hose band

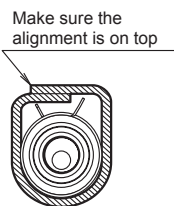

(d) Top view

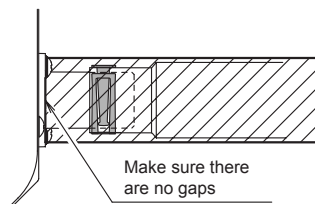

NOTE: Check for drainage

Pour about 1 liter of water from the position shown in the diagram or from the airflow outlet to the dew tray. Check for any abnormalities such as strange noises and whether the drain pump functions normally.

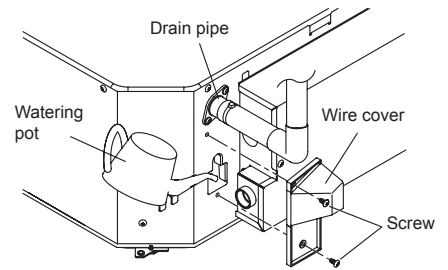

6. ELECTRICAL WIRING

WARNING

Electrical work must be performed in accordance with this Manual by a person certified under the national or regional regulations. Be sure to use a dedicated circuit for the unit. An insufficient power supply circuit or improperly performed electrical work can cause serious accidents such as electric shock or fire.

Before starting work, check that power is not being supplied to the all units.

For wiring, use the prescribed type of cables, connect them securely, making sure that there are no external forces of the cables applied to the terminal connections. Improperly connected or secured cables can cause serious accidents such as overheating the terminals, electric shock, or fire.

Securely install the electrical box cover on the unit. An improperly installed electrical box cover can cause serious accidents such as electric shock or fire through exposure to dust or water.

Install sleeves into any holes made in the walls for wiring. Otherwise, a short circuit could result.

Use the included connection cables and power cables or ones specified by the manufacturer. Improper connections, insufficient insulation, or exceeding the allowable current can cause electric shock or fire.

Do not modify the power cables, use extension cables, or use any branches in the wiring. Improper connections, insufficient insulation, or exceeding the allowable current can cause electric shock or fire.

Match the terminal block numbers and connection cable colors with those of the outdoor unit (or RB unit). Erroneous wiring may cause burning of the electric parts.

Securely connect the connection cables to the terminal board. In addition, secure the cables with wiring holders. Improper connections, either in the wiring or at the ends of the wiring, can cause a malfunction, electric shock, or fire.

Always fasten the outside covering of the connection cable with the cable clamp. (If the insulator is chafed, electric discharge may occur.)

Install an earth leakage breaker. In addition, install the earth leakage breaker so that the entire AC main power supply is cut off at the same time. Otherwise, electric shock or fire could result.

Always connect the earth (ground) cable. Improper earthing (grounding) work can cause electric shocks.

Install the remote controller cables so as not to be direct touched with your hand.

Perform wiring work in accordance with standards so that the air conditioner can be operated safely and positively.

Connect the connection cable firmly to the terminal board. Imperfect installation may cause a fire.

If the supply cable is damaged, it must be replaced by the manufacturer, its service agent or similarly qualified persons in order to avoid a hazard.

CAUTION

Earth (Ground) the unit. Do not connect the earth (ground) cable to a gas pipe, water pipe, lightning rod, or a telephone earth (ground) cable. Improper earthing (grounding) may cause electric shock.

Do not connect power supply cables to the transmission or remote controller terminals, as this will damage the product.

Never bundle the power supply cable and transmission cable, remote control cable together. Separate these cable by 50 mm or more. Bundling these cables together will cause miss operation or breakdown.

When handling PCB, static electricity charged in the body may cause malfunction of the PCB. Follow the cautions below:

- Establish an earth (ground) for the indoor and outdoor units and peripheral devices.
- Cut power (breaker) off.
- Touch metal part of the indoor units for more than 10 seconds to discharge static electricity charged in the body.
- Do not touch terminals of parts and patterns implemented on PCB.

6.1. Electrical requirement

- Select the power cable type and size in accordance with relevant local and national regulations.

Voltage rating	230 V
Operating range	198 to 264 V (50 Hz) 198 to 253 V (60 Hz)

- Specifications for local wiring power cord and branch wiring are in compliance with local code.
- Max. wire length: Set a length so that the voltage drop is less than 2%. Increase the wire diameter when the wire length is long.

Breaker should be installed at every refrigerant system. Do not use a breaker in a different refrigerant system.

Refer to the table for the breaker specifications of each installation condition. Perform the power crossover wiring within the range of the same refrigerant system. When the crossover wiring is done, make a connection for indoor units to satisfy conditions A and B below.

A. Current breaker requirements

Model	MCA	MFA
AUXB004GLEH	0.20 A	20 A
AUXB007GLEH	0.20 A	
AUXB009GLEH	0.20 A	
AUXB012GLEH	0.24 A	
AUXB014GLEH	0.29 A	
AUXB018GLEH	0.30 A	
AUXB024GLEH	0.75 A	

MCA: Minimum Circuit Ampacity
MFA: Maximum Fuse Ampacity
When the power crossover wiring is done, make it so that the total of the MCA of the connected RB units and indoor units does not exceed the 15 A. For RB unit MCA, refer to the RB unit installation manual.
If the capacity of connected RB units and indoor units exceeds the upper limit, either add breakers or use a breaker with a greater capacity.

B. Ground Fault Equipment Breaker requirements

Breaker capacity	* Maximum connectable "indoor units" or "indoor units + RB units"
30 mA, 0.1 sec or less	44 or less
100 mA, 0.1 sec or less	45 to 148 **

* Heat pump type: indoor units, Heat recovery type: indoor units and RB units.

** If the 100 mA capacity breaker is not provided, split the quantity of the indoor units into small groups of 44 units or less and provide a breaker with capacity of 30 mA for each group.

6.1.1. Cable specifications

	Recommended cable size (mm ²)	Cable type	Remark
Power supply cable	2.5	Type60245 IEC57 or equivalent	2 Cable + earth (ground)
Transmission cable	0.33	LONWORKS compatible cable	22 AWG LEVEL 4 (NEMA) non-polar 2 core, twisted pair solid core diameter 0.65 mm
Remote controller cable (2-wire type)	0.33 to 1.25	Sheathed PVC cable*	Non-polar 2 core, twisted pair

*: Use shielded cable in accordance with local rules for remote controller cable.

6.2. Wiring method

Example

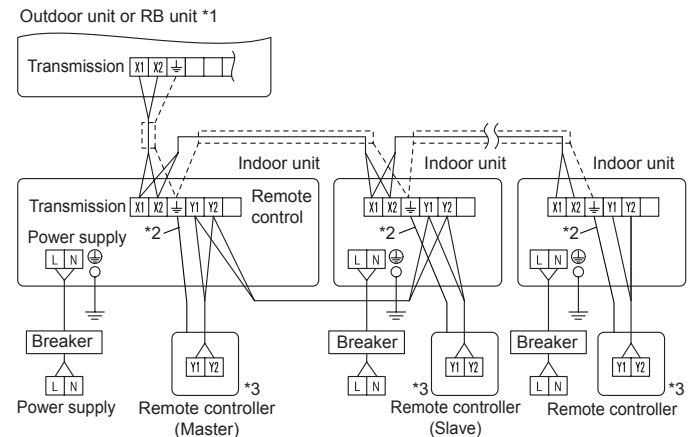

*1: When connecting to the Heat Recovery System, refer to the installation manual of the RB unit.

*2: Earth (Ground) the remote controller if it has an earth (ground) cable.

*3: The 3-wire type remote controller is not used.

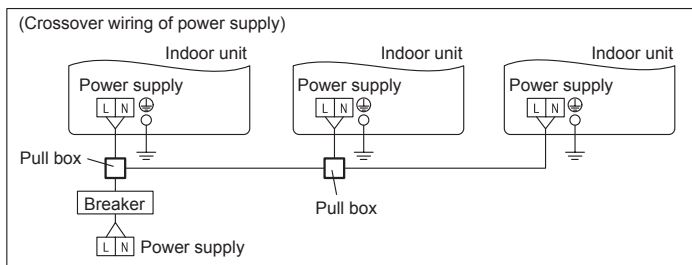

6.3. Unit wiring

Before attaching the cable to terminal block.

6.3.1. Power supply cable

Adjust the length of power supply cable to avoid excessive tension with referring the figure.

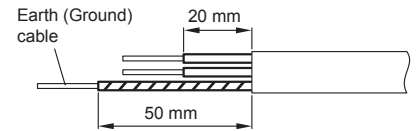

A. For solid core wiring

- To connect the electrical terminal, follow the below diagram and connect after looping it around the end of the cable.
- Use the specified cables, connect them securely, and fasten them so that there is no stress placed on the terminals.
- Use an appropriate screwdriver to tighten the terminal screws. Do not use a screwdriver that is too small, otherwise, the screw heads may be damaged and prevent the screws from being properly tightened.
- Do not tighten the terminal screws too much, otherwise, the screws may break.
- See the table for the terminal screw tightening torques.
- Please do not fix 2 power supply cables with 1 screw.

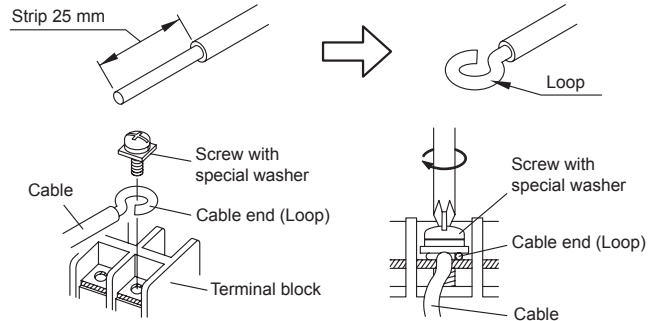

WARNING

When using solid core cables, do not use the ring terminal. If you use the solid core cables with the ring terminal, the ring terminal's pressure bonding may malfunction and cause the cables to abnormally heat up.

B. For strand wiring

- Use ring terminals with insulating sleeves as shown in the figure below to connect to the terminal block.
- Securely clamp the ring terminals to the cables using an appropriate tool so that the cables do not come loose.
- Use the specified cables, connect them securely, and fasten them so that there is no stress placed on the terminals.
- Use an appropriate screwdriver to tighten the terminal screws. Do not use a screwdriver that is too small, otherwise, the screw heads may be damaged and prevent the screws from being properly tightened.
- Do not tighten the terminal screws too much, otherwise, the screws may break.
- See the table for the terminal screw tightening torques.
- Please do not fix 2 power supply cables with 1 screw.

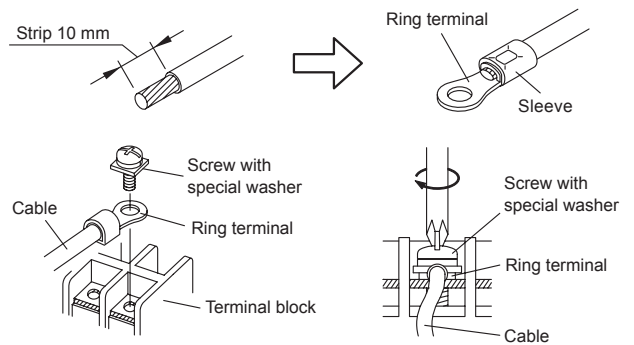

WARNING

Use ring terminals and tighten the terminal screws to the specified torques, otherwise, abnormal overheating may be produced and possibly cause heavy damage inside the unit.

Tightening torque

M4 screw (Power supply /L, N, GND)	1.2 to 1.8 N·m (12 to 18 kgf·cm)
------------------------------------	----------------------------------

6.3.2. Transmission and Remote controller cable

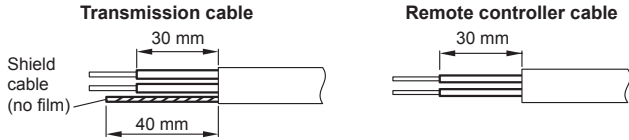

• Connect remote controller and transmission cables as shown in the figure below.

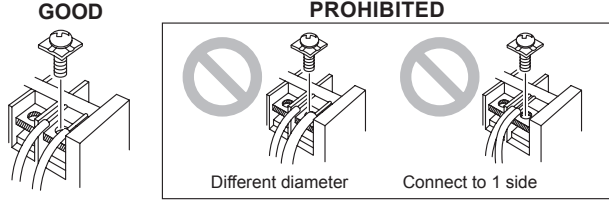

⚠ WARNING

Tighten the terminal screws to the specified torques, otherwise, abnormal overheating may be produced and possibly cause heavy damage inside the unit.

Tightening torque

M3 screw (Transmission /X1, X2) (Remote controller /Y1, Y2)	0.5 to 0.6 N·m (5 to 6 kgf·cm)
--	--------------------------------

⚠ CAUTION

To peel the film from the lead cable, use a dedicated tool that will not damage the conductor cable.

When installing a screw on the terminal block, do not cut the wire by overtightening the screw. On the other hand, an undertightened screw can cause faulty contact, which will lead to a communication failure.

6.4. Connection of wiring

(1) Remove the control box cover and install each connection cable.

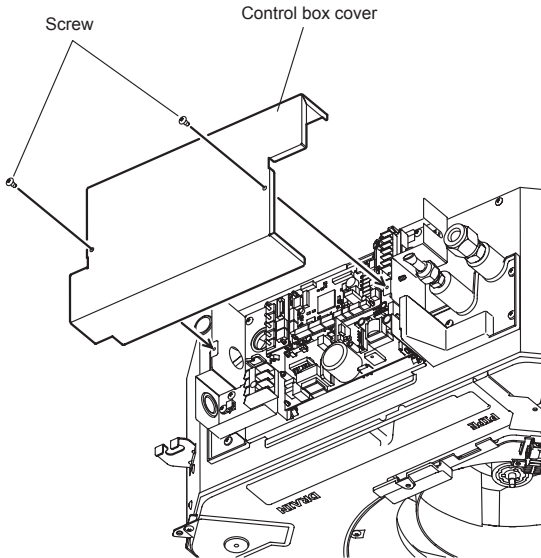

(2) Connect the connection cable, with the cable tie.

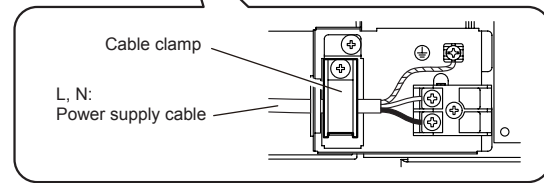
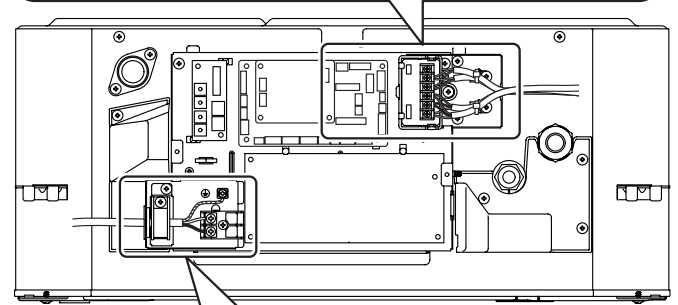
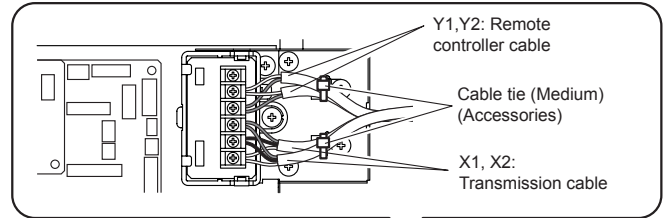

(3) Install control box cover.

⚠ CAUTION

Do not bundle the remote controller cable, or wire the remote controller cable in parallel, with the indoor unit connection cable (to the outdoor unit) and the power supply cable. It may cause erroneous operation.

6.5. Optional parts wiring

6.5.1. Layout of the indoor unit PCB

⚠ CAUTION

Do not operate any switches other than prescribed, as it can cause the unit to operate improperly or malfunction.

Use an insulated screwdriver to set the DIP switches.

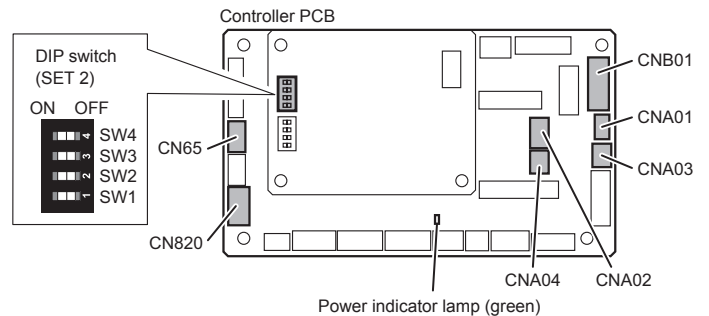

Name	Application	
CNA01	Apply voltage terminal	For external input
CNA03	Dry contact terminal	
CNA02		
CNA04		
DIP switch SET 2 (SW2)	Input signal type switching	
CNB01	Output terminal	For external output
CN65	For one of the following. • MODBUS® convertor (*1) • Wireless LAN adapter (*1)	
CN820	For External power supply unit (*1)	

*1: For details, refer to each installation manual.

6.5.2. Power indicator lamp status

Power indicator lamp (Green)	Status contents
○ Lit	Lit when the power is turned on.
● Fast flashing (every 0.1 second)	There is a fault with the communication board or the main board.
● Blinking (repeat 3 seconds ON and 1 second OFF)	The indoor unit is turned off and power is supplied from the External power supply unit (optional) to the indoor unit PCB.

6.5.3. Connection methods

Wire modification for External input/output wire

- Remove insulation from wire attached to wire kit connector.
- Remove insulation from field supplied cable. Use crimp type insulated butt connector to join field cable and wire kit wire.
- Connect the wire with connecting wire with solder.

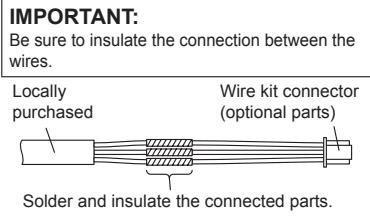

Wiring arrangement

In following figure, all the possible connectors are connected for description. In actual installation, you cannot connect all the connectors at once.

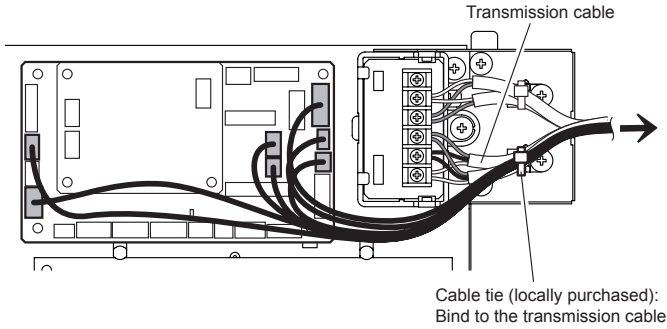

6.6. External input and external output (Optional parts)

(1) External input

- Indoor unit can be Operation/Stop, Emergency stop or Forced stop by using indoor unit PCB CNA01 or CNA02.
- "Operation/Stop" mode, "Emergency stop" mode or "Forced stop" mode can be selected with function setting of indoor unit.
- Indoor unit can be Forced thermostat off by using indoor unit PCB CNA03 or CNA04.
- A twisted pair cable (22 AWG) should be used. Maximum length of cable is 150 m.
- Use an external input and output cable with appropriate external dimension, depending on the number of cables to be installed.
- The wire connection should be separate from the power cable line.

Input select

Use either one of these types of terminal according to the application. (Both types of terminals cannot be used simultaneously.)

• Apply voltage terminal ([CNA01], [CNA03])

When a power supply must be provided at the input device you want to connect, use the Apply voltage terminal ([CNA01], [CNA03]).

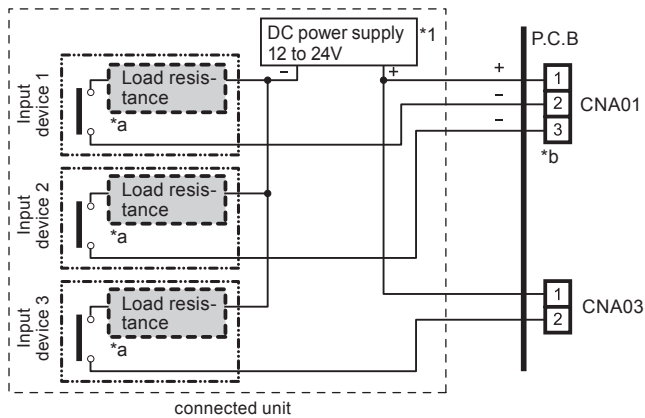

*1 Make the power supply DC12 to 24V. Select a power supply capacity with an ample surplus for the connected load.
Do not impress a voltage exceeding 24V across pins 1-2, and 1-3.

*a The allowable current is DC 5mA to 10mA. (Recommended: DC5mA)
Provide a load resistance such that the current becomes DC10mA or less.
Select very low current use contacts (usable at DC12V, DC1mA or less).

*b The polarity is [+] for pin 1 and [-] for pin 2 and 3. Connect correctly.

When connected to Apply voltage terminals of multiple indoor units with a connected unit, be sure to make a branch outside the indoor unit using a pull box, etc. as shown on below example.

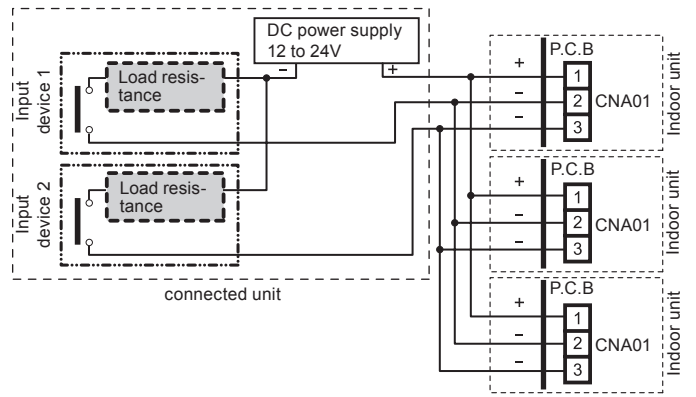

• Dry contact terminal ([CNA02], [CNA04])

When a power supply is unnecessary at the input device you want to connect, use the Dry contact terminal ([CNA02], [CNA04]).

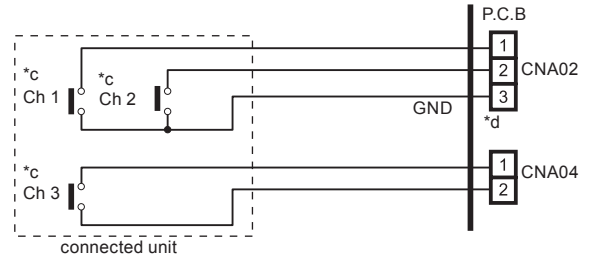

*c Select very low current use contacts (usable at DC12V, DC1mA or less).

*d The wiring is different from Apply voltage terminals. Be sufficiently careful when wiring.

When connected to Dry contact terminals of multiple indoor units with a connected unit, insulate each indoor unit with relay, etc. as shown on below example.

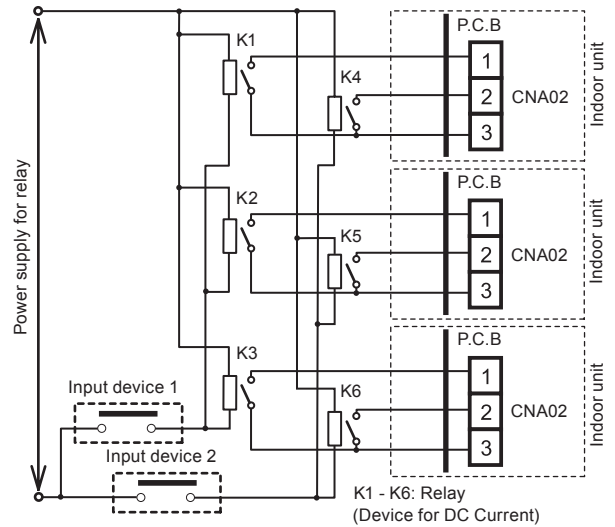

NOTE :

When connected to multiple indoor units directly, it will cause breakdown.

Operation behavior

• Input signal type

The input signal type can be selected.

It is switched by DIP switch on the indoor unit PCB.

DIP switch [Set 2 SW2]	Input signal type
OFF (Factory setting)	Edge
ON	Pulse

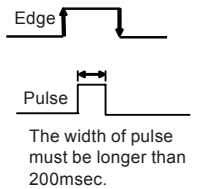

• When function setting is "Operation/Stop" mode.

[In the case of "Edge" input]

Connector	Input signal	Command
Ch1 of CNA01 or CNA02	OFF → ON	Operation
	ON → OFF	Stop

[In the case of "Pulse" input]

Connector	Input signal	Command	
CNA01 or CNA02	Ch1	OFF → ON	Operation
	Ch2	OFF → ON	Stop

* The last command has priority.

* The indoor units within the same remote controller group operates in the same mode.

- When function setting is “Emergency stop” mode.
[In the case of “Edge” input]

Connector	Input signal	Command
Ch1 of CNA01 or CNA02	OFF → ON	Emergency stop
	ON → OFF	Normal

[In the case of “Pulse” input]

Connector	Input signal	Command	
CNA01 or CNA02	Ch1	OFF → ON	Emergency stop
	Ch2	OFF → ON	Normal

* All indoor units of same refrigerant system stops when Emergency stop operates.

- When function setting is “Forced stop” mode.
[In the case of “Edge” input]

Connector	Input signal	Command
Ch1 of CNA01 or CNA02	OFF → ON	Forced stop
	ON → OFF	Normal

[In the case of “Pulse” input]

Connector	Input signal	Command	
CNA01 or CNA02	Ch1	OFF → ON	Forced stop
	Ch2	OFF → ON	Normal

* When the forced stop is triggered, indoor unit stops and Operation/Stop operation by a remote controller is restricted.

* When forced stop function is used with forming a remote controller group, connect the same equipment to each indoor unit within the group.

• Selection method of functions
“Operation/Stop” mode or “Emergency stop” mode, “Forced stop” mode can be selected with function setting of indoor unit.

- Forced thermostat off function
[“Edge” input only]

Function setting	Connector	Input signal	Command
60-00	Ch3 of CNA03 or CNA04	OFF → ON	Thermostat off
		ON → OFF	Normal

- Refrigerant leak detection function (only for J-III L series)
[“Edge” input only]

Function setting	Connector	Input signal	Command
60-09	Ch3 of CNA03 or CNA04	OFF → ON	No command
		ON → OFF	Refrigerant leak

(2) External output

- A twisted pair cable (22AWG) should be used. Maximum length of cable is 25m.
- Use an external input and output cable with appropriate external dimension, depending on the number of cables to be installed.
- Output voltage: Hi DC12V±2V, Lo 0V.
- Permissible current: 50mA

Output select

- When indicator etc. are connected directly

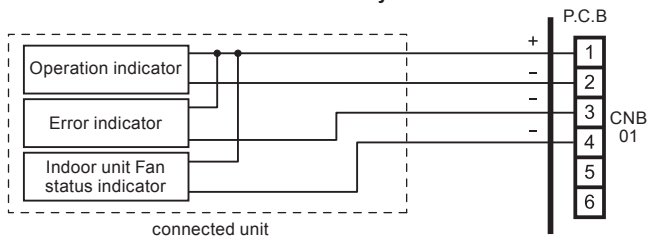

- When connecting with unit equipped with a power supply

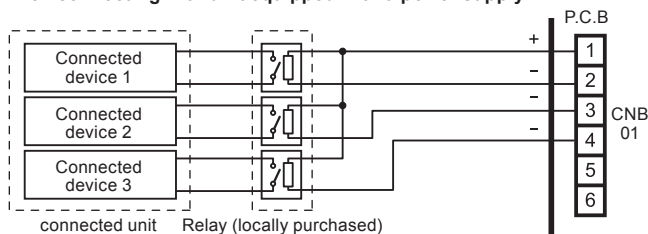

Operation behavior

Connector	Output voltage	Status	
CNB01	External output1 Pins 1-2	0V	Stop
		DC 12 V	Operation
	External output2 Pins 1-3	0V	Normal
		DC 12 V	Error
	External output3 Pins 1-4	0V	Indoor unit fan stop
		DC 12 V	Indoor unit fan operation

7. FIELD SETTING

There are 3 methods for address setting by FIELD SETTING as follows.

Set by either of the methods.

Each setting method is described (1) to (3) below.

- (1) IU AD, REF AD SW settings: This section (7.1. Setting the address)
- (2) Remote controller settings: Refer to the wired or wireless remote controller manual for detailed setting information. (Set IU AD, REF AD SW to 0)
- (3) Automatic address settings: Refer to the outdoor unit manual for detailed setting information. (Set IU AD, REF AD SW to 0)

CAUTION

Be sure to turn OFF the power before performing the field setting.

Do not operate any switches other than prescribed, as it can cause the unit to operate improperly or malfunction.

Use an insulated screwdriver to set the DIP switches.





7.1. Setting the address

Manual address setting method

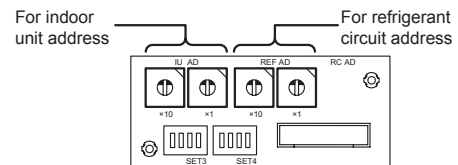
CAUTION

Use an insulated screwdriver to set the dip switches.



Setting	Setting range	Type of switch
Indoor unit address	0 to 63	Setting example 2  IU AD×10  IU AD×1
Refrigerant circuit address	0 to 99	Setting example 63  REF AD×10  REF AD×1

(1) Indoor unit address

Rotary switch (IU AD ×1)...Factory setting “0”

Rotary switch (IU AD ×10)...Factory setting “0”

When connecting multiple indoor units to 1 refrigerant system, set the address at IU AD SW as shown in the Table A.

(2) Refrigerant circuit address

Rotary switch (REF AD ×1)...Factory setting “0”

Rotary switch (REF AD ×10)...Factory setting “0”

In the case of multiple refrigerant systems, set REF AD SW as shown in the Table A for each refrigerant system.

Set to the same refrigerant circuit address as the outdoor unit.

- If working in an environment where the wireless remote controller can be used, the addresses can also be set using the remote controller.
- If setting the addresses using the wireless remote controller, set the indoor unit address and refrigerant circuit address to “00”. (For information on setting using the wireless remote controller.)

Table A

Refrigerant circuit	Rotary switch setting		Address	Rotary switch setting	
	REF AD SW × 10	× 1		Indoor unit × 10	× 1
0	0	0	0	0	0
1	0	1	1	0	1
2	0	2	2	0	2
3	0	3	3	0	3
4	0	4	4	0	4
5	0	5	5	0	5
⋮	⋮	⋮	⋮	⋮	⋮
10	1	0	10	1	0
11	1	1	11	1	1
⋮	⋮	⋮	⋮	⋮	⋮
99	9	9	63	6	3

* Do not set the indoor unit address (IU AD SW) at 64 to 99. It may result in failure.

7.2. Custom code setting

- Selecting the custom code prevents the indoor unit mix-up. (figure below) (Up to 4 codes can be set.)
- Perform the setting for both the indoor unit and the remote controller.

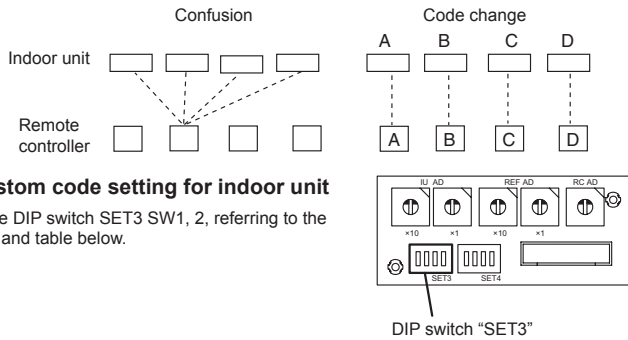

• Custom code setting for indoor unit

Set the DIP switch SET3 SW1, 2, referring to the figure and table below.

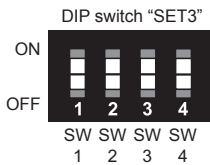

DIP switch SET3	Custom code			
	A (Factory setting)	B	C	D
SW1	OFF	ON	OFF	ON
SW2	OFF	OFF	ON	ON

⚠ CAUTION

Do not operate any switches other than prescribed, as it can cause the unit to operate improperly or malfunction.

7.3. Function setting

- FUNCTION SETTING can be performed with the wired or wireless remote controller. (The remote controller is optional equipment)
- Refer to the wired or wireless remote controller manual for detailed setting information.
- Refer to "7.1. Setting the address" for indoor unit address and refrigerant circuit address settings.
- Turn the power of the indoor unit ON before starting the setting.
- * Turning on the power to the indoor units initializes EEV, so make sure the piping air tight test and vacuuming have been conducted before turning on the power.
- * Also check again to make sure no wiring mistakes were made before turning on the power.

Function details

Function	Function number	Setting number	Default	Details
Filter indicator interval	11	00 Standard	○	Adjust the filter cleaning interval notification. If the notification is too early, change to setting 01. If the notification is too late, change to setting 02.
		01 Longer		
		02 Shorter		
Filter indicator action	13	00 Enable	○	Enable or disable the filter indicator. Setting 02 is for use with a central remote controller.
		01 Disable		
		02 Display only on central remote controller		
Ceiling airflow	20	00 Standard	○	Regulate the airflow according to the needs of the installation location. When set to 01, the airflow will be stronger. (Cassette type only)
		01 High Ceiling		
Vertical airflow direction	23	00 Standard	○	Adjust the vertical airflow direction. All airflow direction louvers are adjusted together. (Cassette type only)
		01 Raise		
(Forbidden)	24		○	
(Forbidden)	26		○	
(Forbidden)	27		○	
Cool air temperature trigger	30	00 Standard	○	Adjust the cool air trigger temperature. To lower the trigger temperature, use setting 01. To raise the trigger temperature, use setting 02.
		01 Adjust (1)		
		02 Adjust (2)		
Heat air temperature trigger	31	00 Standard	○	Adjust the heat air trigger temperature. To lower the trigger temperature by 6 degrees C, use setting 01. To lower the trigger temperature by 4 degrees C, use setting 02. To raise the trigger temperature, use setting 03.
		01 Adjust (1)		
		02 Adjust (2)		
Auto restart	40	00 Enable		Enable or disable automatic system restart after a power outage.
		01 Disable	○	
Cool Air Prevention	43	00 Super low	○	Restrain the cold airflow with making the airflow lower when starting heating operation. To correspond to the ventilation, set to 01.
		01 Follow the setting on the remote controller		

Function	Function number	Setting number	Default	Details
External control	46	00 Start/Stop	○	Allow an external controller to start or stop the system, or to perform an emergency stop. * If an emergency stop is performed from an external controller, all refrigerant systems will be disabled. * If forced stop is set, indoor unit stops by the input to the external input terminals, and Start/Stop by a remote controller is restricted.
		01 Emergency stop		
		02 Forced stop		
Error report target	47	00 All	○	Change the target for reporting errors. Errors can either be reported in all locations, or only on the central remote controller.
Fan setting when cooling thermostat OFF	49	00 Follow the setting on the remote controller	○	When set to 01, the fan stops when the thermostat is OFF in cooling operation. Connection of the wired remote controller (2-wire type or 3-wire type) and switching its thermostat are necessary.
		01 Stop		
Switching function for external inputs	60	00 Forced thermostat off	○	Setting is required when connecting a refrigerant-leak detecting device. (only for J-III series)
		01 (Forbidden)		
		02 (Forbidden)		
		03 (Forbidden)		
		04 (Forbidden)		
		05 (Forbidden)		
		06 (Forbidden)		
		07 (Forbidden)		
		08 (Forbidden)		
		09 Refrigerant leak detection		
(Forbidden)	61	00	○	
(Forbidden)	62	00	○	
Auto mode type	68	00 Single setpoint auto mode (traditional)	○	Switch the setting method of auto mode to single or dual (cooling/heating). For heat pump systems, it is necessary to set the master indoor unit (by wired remote controller).
		01 Dual setpoint auto mode		
Deadband value	69	00 0°C	○	Choose the minimum temperature between cooling and heating settings (deadband) for Dual setpoint auto mode (set in No. 68).
		01 0.5°C		
		02 1.0°C		
		03 1.5°C		
		04 2.0°C		
		05 2.5°C		
		06 3.0°C		
		07 3.5°C		
		08 4.0°C		
09 4.5°C				
(Forbidden)	70	00	○	
(Forbidden)	72	00	○	
(Forbidden)	73	00	○	
(Forbidden)	74	00	○	
(Forbidden)	75	00	○	

7.3.1. Button name and function

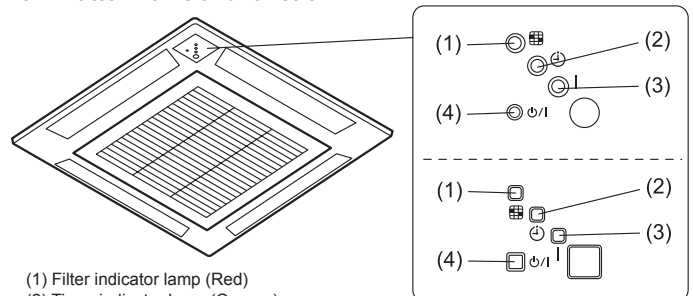

- (1) Filter indicator lamp (Red)
- (2) Timer indicator lamp (Orange)
- (3) Operation indicator lamp (Green)
- (4) Manual auto button

7.3.2. Checking the function settings

Press and hold the "MANUAL AUTO" button on the indoor unit for 3 seconds to check the function settings. It is necessary to disconnect the power in order to return to normal operation mode.

(1) Indoor unit and refrigerant address indication

Indication pattern

Indicator lamp name	Indication pattern	
	Indoor unit address	Refrigerant address
OPERATION (Green)	ON	Flash (1.0s ON/1.0s OFF)
TIMER (Orange)	Address: tens place (0.5s ON/0.5s OFF)	
FILTER (Red)	Address: ones place (0.5s ON/0.5s OFF)	

• Indoor unit address example

(Example) ADDRESS : 24

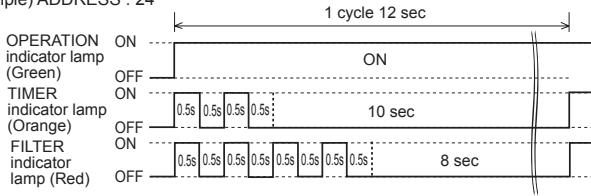

• Refrigerant address example

(Example) ADDRESS : 30

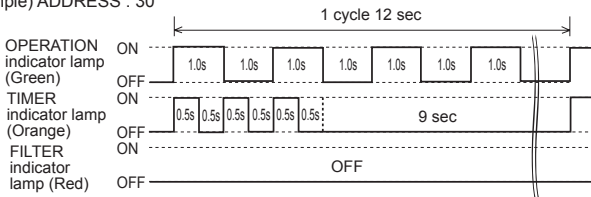

• Setting details

Function number	Item	Setting number
01	Indoor unit address	00 to 63
02	Refrigeration address	00 to 99

For use with a remote controller, set all rotary switches to 0, and refer to "7.1. Setting the address" for details.

All switches are set to 0 at the factory.

(2) Others

Indication pattern

Indicator lamp	Indication pattern
OPERATION (Green)	Function number; tens place (0.5s ON/0.5s OFF)
TIMER (Orange)	Function number; ones place (0.5s ON/0.5s OFF)
FILTER (Red)	Setting number: (0 to 9) (0.5s ON/0.5s OFF)

(Example) Function : 31, Setting number : 2

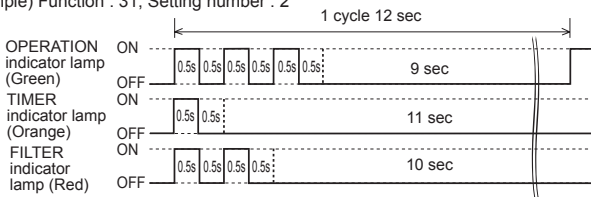

8. CASSETTE GRILLE INSTALLATION

8.1. Remove the intake grille

- Slide the 2 grille hook

Standard type

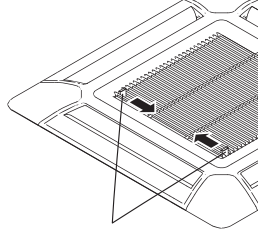

Grille hook

Grid type

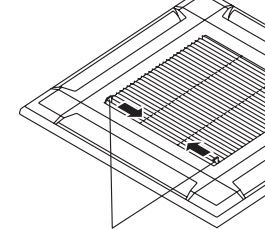

Grille hook

- Open the intake grille and remove.

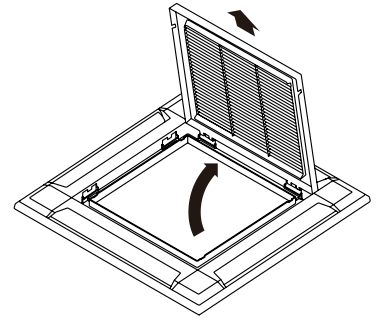

8.2. Install cassette grille to indoor unit

- Install the cassette grille on the indoor unit.

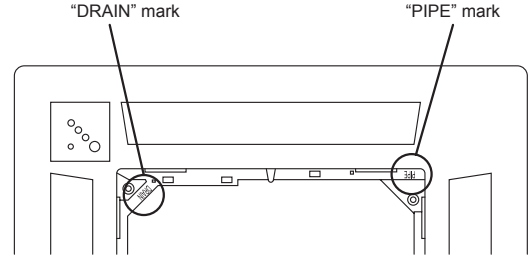

- * Align the stamped marks on the cassette grille against the pipe and the drain of the indoor unit.

CAUTION

Use only the supplied screws to install the cassette grille.

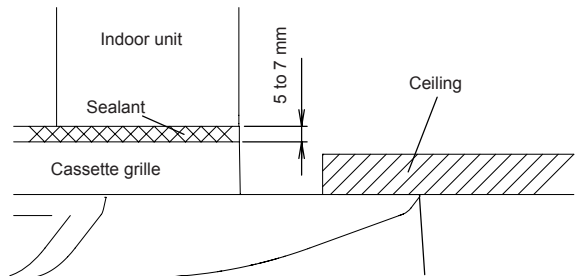

No gap between ceiling and cassette grille around entire periphery

- Connect the connector.

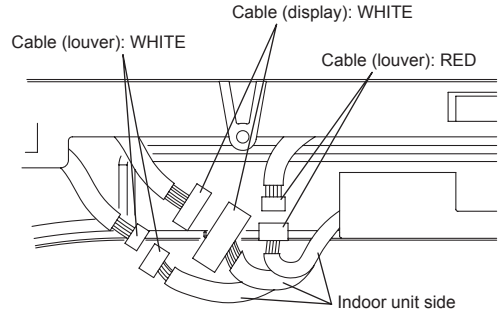

- Arrange the cables as illustrated below.

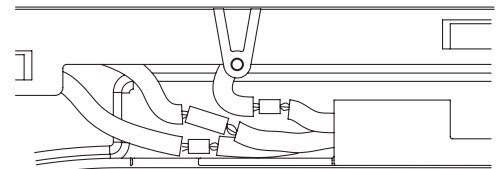

- Attach the connector cover.

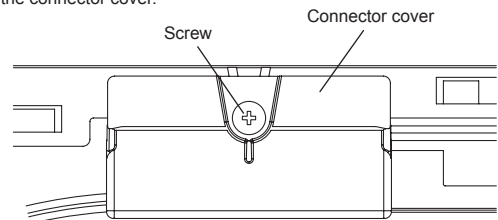

8.3. Attach the intake grille

The installation is the reverse of "REMOVING THE INTAKE GRILLE".
The intake grille can be rotated and installed 4 ways to suit the user's preference.

 CAUTION
The louver angle cannot be changed if the power is not on, (If moved by hand, it may be damaged.)
The grille assembly is directional relative to the air conditioner body.
Install so that there is no gap between the grille assembly and the air conditioner body.

9. TEST RUN

9.1. Test run using Outdoor unit (PCB)

- Refer to the Installation Manual for the outdoor unit if the PCB for the outdoor unit is to be used for the test run.

9.2. Test run using Remote Controller

- Refer to the Installation Manual for the remote controller to perform the test run using the remote controller.
- When the air conditioner is being test run, the OPERATION and TIMER indicator lamps flash slowly at the same time.

10. CHECK LIST

Pay special attention to the check items below when installing the indoor unit(s). After installation is complete, be sure to check the following check items again.

CHECK ITEMS	If not performed correctly	CHECK BOX
Has the indoor unit been installed correctly?	Vibration, noise, indoor unit may drop	
Has there been a check for gas leaks (refrigerant pipes)?	No cooling, No heating	
Has heat insulation work been completed?	Water leakage	
Does water drain easily from the indoor units?	Water leakage	
Is the voltage of the power source the same as that indicated on the label on the indoor unit?	No operation, heat or burn damage	
Are the wires and pipes all connected completely?	No operation, heat or burn damage	
Is the indoor unit earthed (grounded)?	Short circuit	
Is the connection cable the specified thickness?	No operation, heat or burn damage	
Are the inlets and outlets free of any obstacles?	No cooling, No heating	
Does start and stop air conditioner operation by remote control unit or external device?	No operation	
After installation is completed, has the proper operation and handling been explained to the user?		

11. ERROR CODES

If you use a wired type remote controller, error codes will appear on the remote controller display. If you use a wireless remote controller, the lamp on the photodetector unit will output error codes by way of blinking patterns. See the lamp blinking patterns and error codes in the table below.

Error indications			Wired remote controller error code	Error contents
OPERATION lamp (green)	TIMER lamp (orange)	FILTER lamp (red)		
● (1)	● (2)	◇	12	Remote controller communication error
● (1)	● (4)	◇	14	Network communication error
● (1)	● (6)	◇	16	Peripheral unit communication error
● (2)	● (6)	◇	26	Indoor unit address setting error
● (2)	● (9)	◇	29	Connection unit number error in wired remote controller system
● (3)	● (1)	◇	31	Indoor unit power supply abnormal
● (3)	● (2)	◇	32	Indoor unit main PCB error
● (3)	● (10)	◇	3A	Indoor unit communication circuit (wired remote controller) error
● (4)	● (1)	◇	41	Indoor unit room temp. thermistor error
● (4)	● (2)	◇	42	Indoor unit heat ex. temp. thermistor error
● (5)	● (1)	◇	51	Indoor unit fan motor 1 error
● (5)	● (2)	◇	52	Indoor unit coil (expansion valve) error
● (5)	● (3)	◇	53	Indoor unit water drain abnormal
● (9)	● (15)	◇	9U	Outdoor unit miscellaneous error
● (10)	● (8)	◇	AB	Poor refrigerant circulation
● (13)	● (1)	◇	J1	RB unit error

Display mode ● : 0.5 s ON / 0.5 s OFF

◇ : 0.1 s ON / 0.1 s OFF

() : Number of flashing

Wired remote controller display

UTY-RNR*Z* (2-wire type)

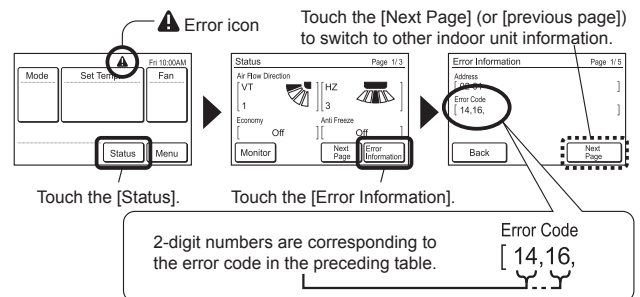

For more information, refer to the installation manual of the remote controller.

UTY-RLR* (2-wire type)

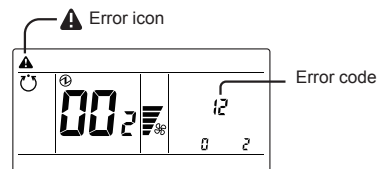

For more information, refer to the installation manual of the remote controller.