

• **Model: AUXB012GLEH**

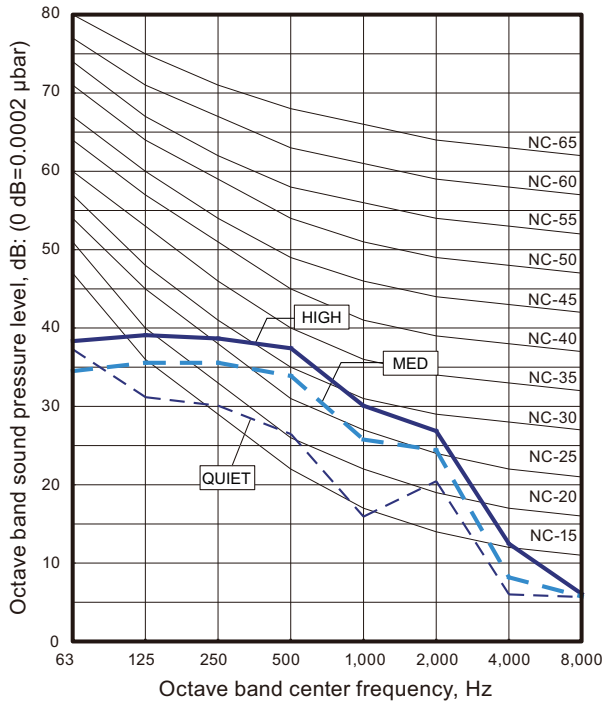

• **Model: AUXB014GLEH**

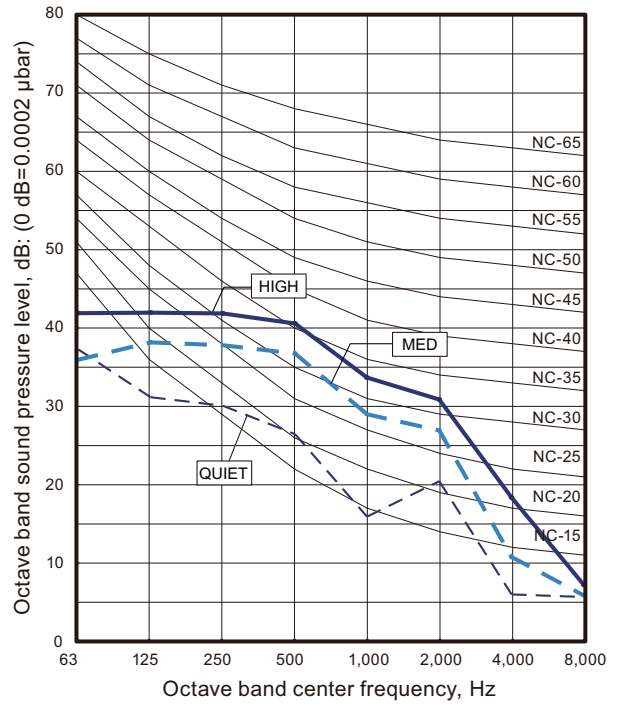

• **Model: AUXB018GLEH**

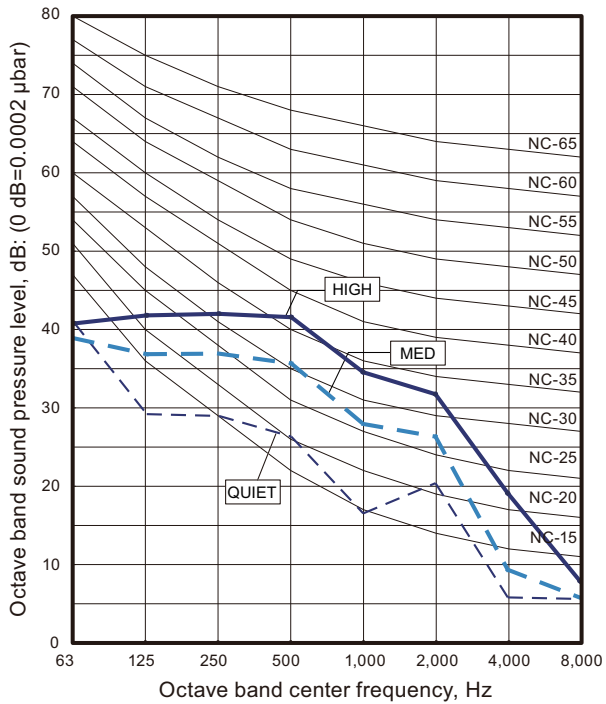

• **Model: AUXB024GLEH**

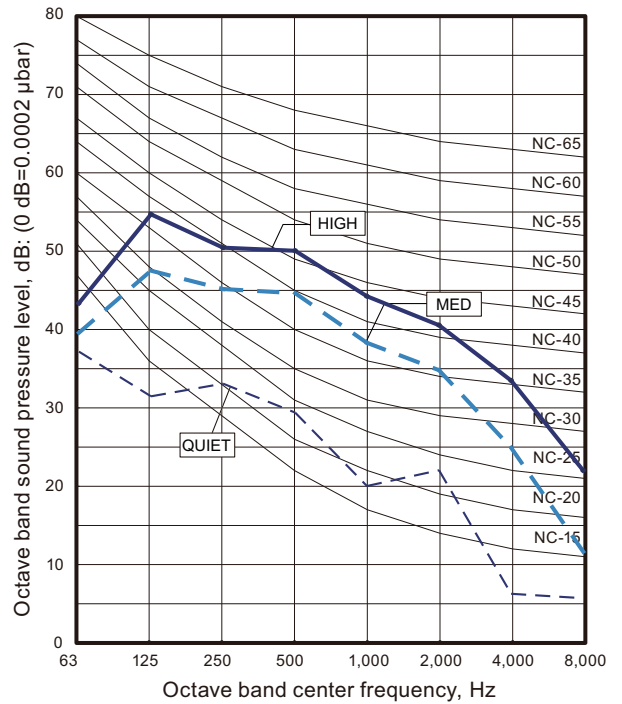

INDOOR
UNITS

INDOOR
UNITS

9-17. Sound level check point

- Compact cassette type
- Circular flow cassette type
- Cassette type

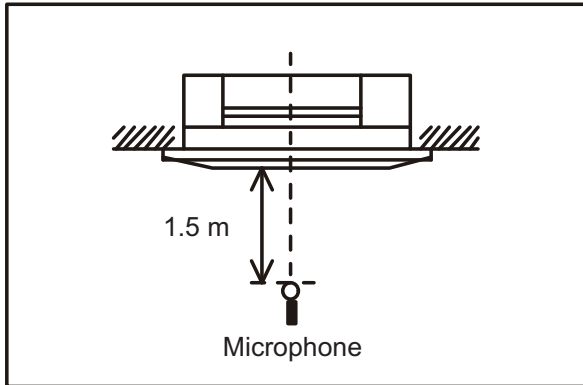

- Low static pressure duct (Mini duct) type
- Low static pressure duct (Slim duct) type
- Medium static pressure duct type
- High static pressure duct type

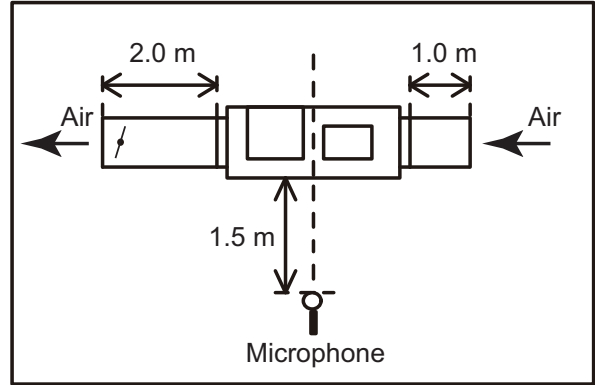

- Compact floor type

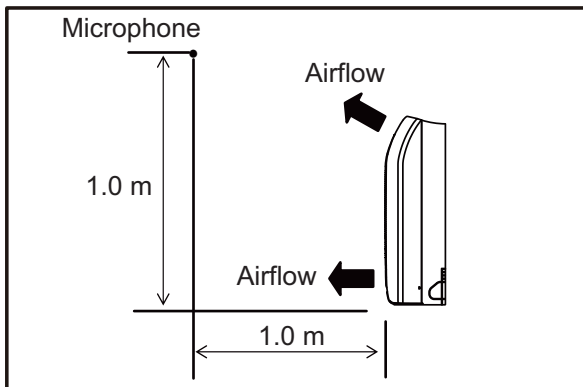

- 3D flow cassette type

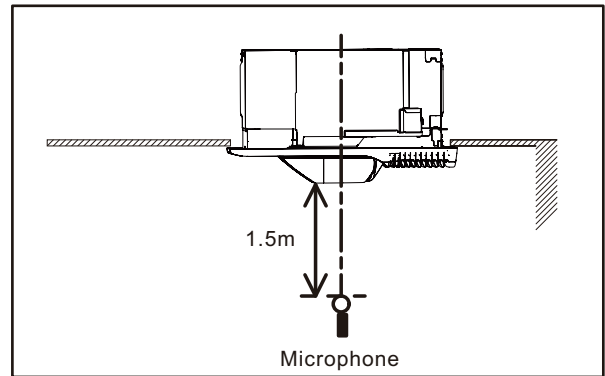

- Floor/Ceiling type
- Ceiling type

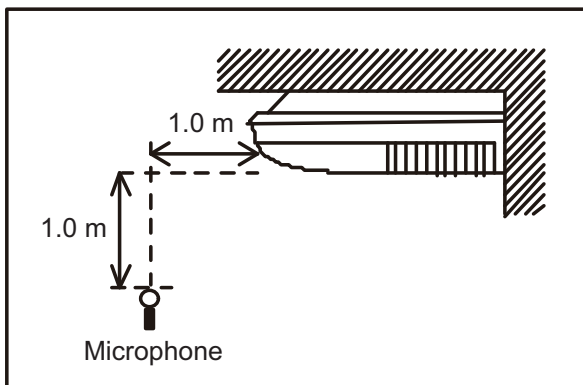

- Wall mounted type

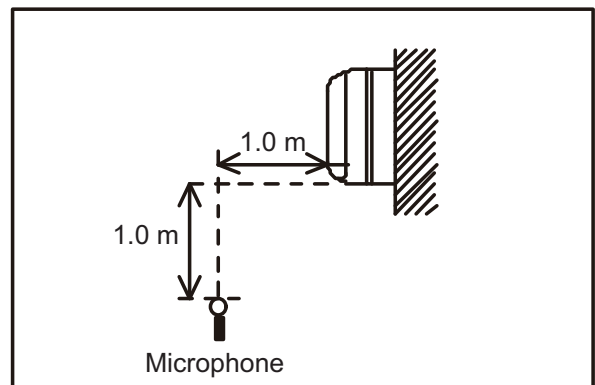

INDOOR
UNITS

INDOOR
UNITS