

9-3. Circular flow cassette type

- Model: AUXM018GLEH

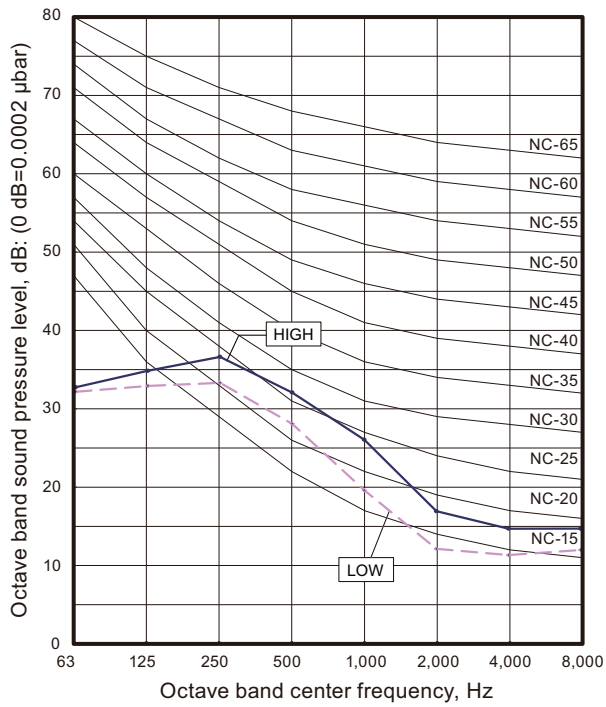

- Model: AUXM024GLEH

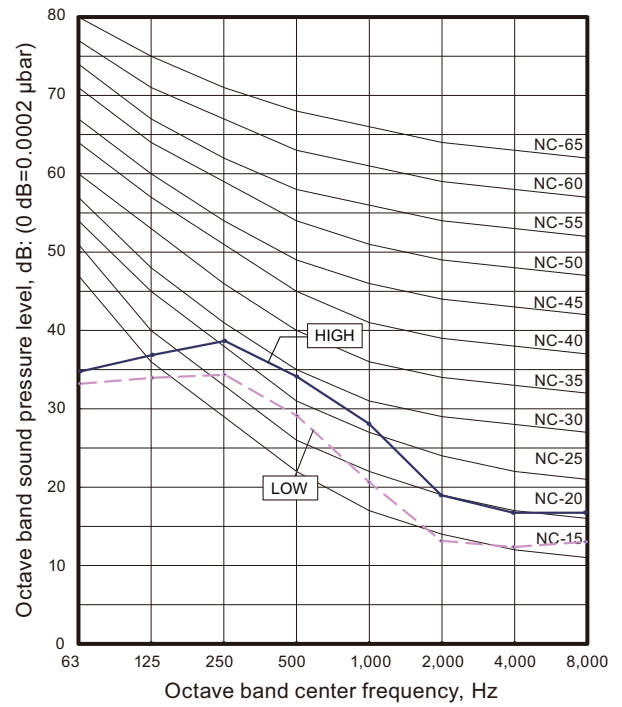

- Model: AUXM030GLEH

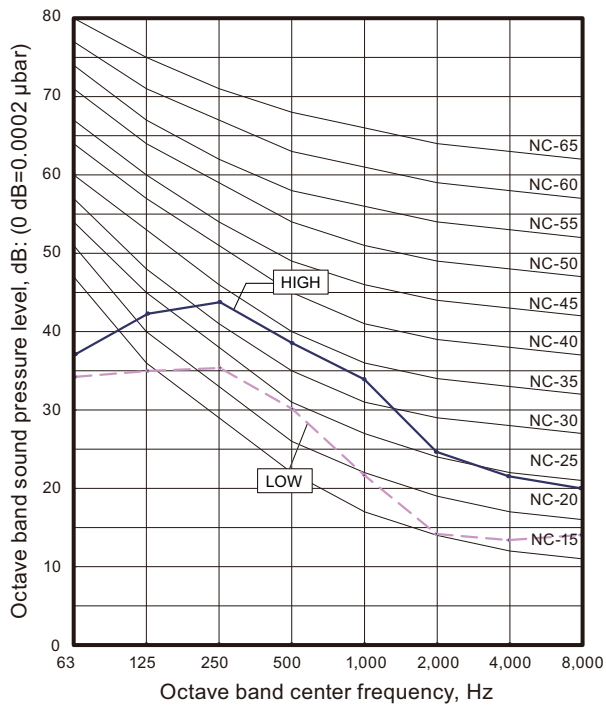

- Models: AUXK018GLEH and AUXK024GLEH

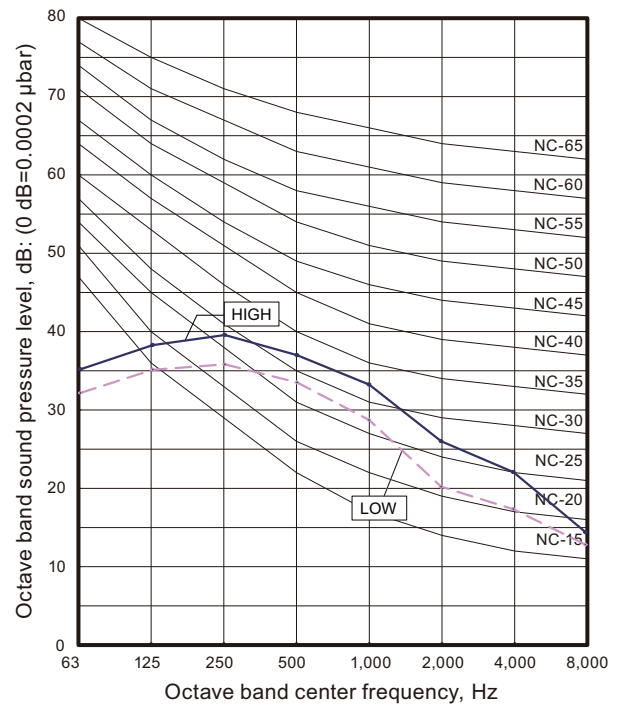

INDOOR
UNITS

INDOOR
UNITS

9-17. Sound level check point

- Compact cassette type
- Circular flow cassette type
- Cassette type

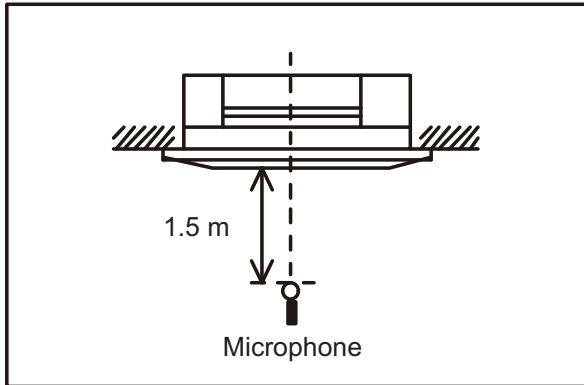

- Low static pressure duct (Mini duct) type
- Low static pressure duct (Slim duct) type
- Medium static pressure duct type
- High static pressure duct type

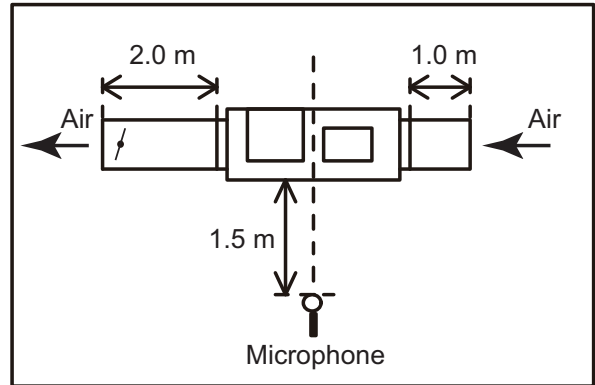

- Compact floor type

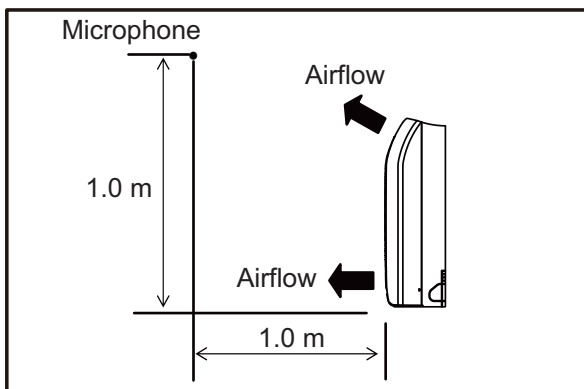

- 3D flow cassette type

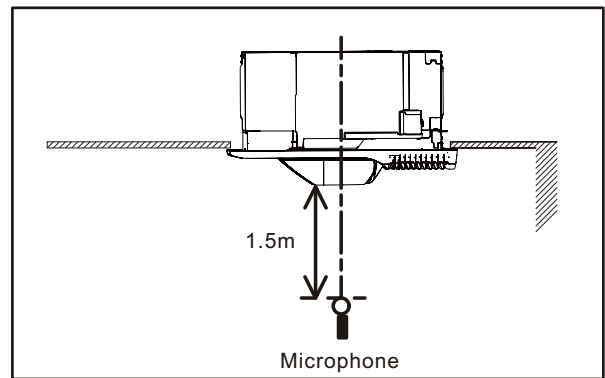

- Floor/Ceiling type
- Ceiling type

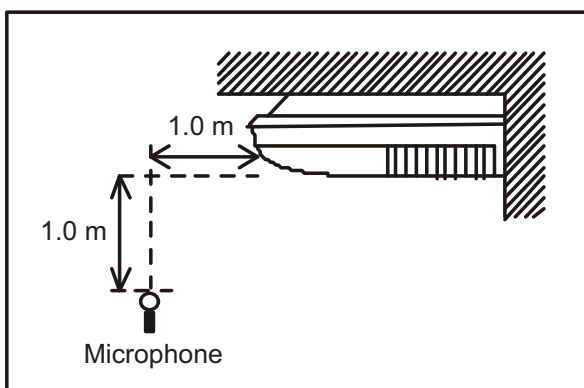

- Wall mounted type

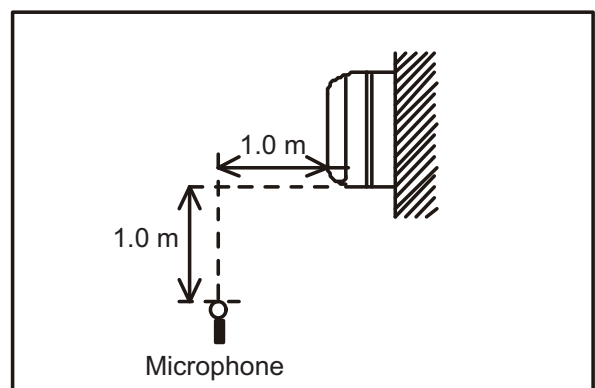

INDOOR
UNITS

INDOOR
UNITS