

AUXV004GLEH
AUXV007GLEH
AUXV009GLEH
AUXV012GLEH
AUXV014GLEH
AUXV018GLEH
AUXV024GLEH

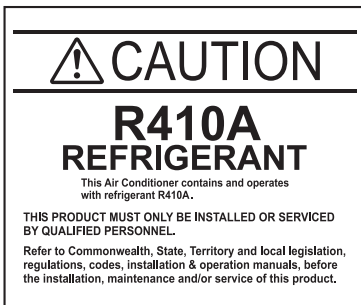

Refer to the rating label for the serial number,
manufactured year and month.

FUJITSU GENERAL LIMITED

INSTALLATION MANUAL

INDOOR UNIT (1-way flow cassette type)

For authorized service personnel only.

English

INSTALLATIONSANLEITUNG

INNENGERÄT (1-Weg-Fluss-Kassettentyp)

Nur für autorisiertes Fachpersonal.

Deutsch

MANUEL D'INSTALLATION

UNITÉ INTÉRIEURE (Type cassette à flux 1 voie)

Pour le personnel agréé uniquement.

Français

MANUAL DE INSTALACIÓN

UNIDAD INTERIOR (Tipo casete de flujo de 1 dirección)

Únicamente para personal de servicio autorizado.

Español

MANUALE DI INSTALLAZIONE

UNITÀ INTERNA (tipo a cassetta flusso a 1 via)

A uso esclusivo del personale tecnico autorizzato.

Italiano

ΕΓΧΕΙΡΙΔΙΟ ΕΓΚΑΤΑΣΤΑΣΗΣ

ΕΣΩΤΕΡΙΚΗ ΜΟΝΑΔΑ (Τύπος κασέτας ροής 1 δρόμου)

Μόνο για εξουσιοδοτημένο τεχνικό προσωπικό.

Ελληνικά

MANUAL DE INSTALAÇÃO

UNIDADE INTERIOR (tipo de casete de fluxo 1 via)

Apenas para técnicos autorizados.

Português

РУКОВОДСТВО ПО УСТАНОВКЕ

ВНУТРЕННИЙ МОДУЛЬ (1-сторонний кассетного типа с воздушным потоком)

Только для авторизованного обслуживающего персонала.

Русский

MONTAJ KILAVUZU

İÇ ÜNİTE (1 yönlü akış kaset tipi)

Yalnızca yetkili servis personeli için.

Türkçe

MADE IN P.R.C.



PART No. 9384723017

INSTALLATION MANUAL

PART No. 9384723017

VRF system indoor unit (1-way flow cassette type)

[Original instructions]

Contents

1. SAFETY PRECAUTIONS.....	1
2. ABOUT THIS PRODUCT.....	1
2.1. Precautions for using the R410A refrigerant.....	1
2.2. Special tool for R410A.....	1
2.3. Accessories.....	2
2.4. Optional parts.....	2
3. INSTALLATION WORK.....	2
3.1. Selecting an installation location.....	2
3.2. Preparation before installation.....	2
3.3. Installation dimensions.....	3
3.4. Installing the unit.....	3
4. PIPE INSTALLATION.....	4
4.1. Selecting the pipe material.....	4
4.2. Pipe requirement.....	4
4.3. Flare connection (pipe connection).....	4
4.4. Installing heat insulation.....	5
5. INSTALLING DRAIN PIPES.....	5
5.1. Drain piping.....	5
5.2. Install the drain pipe.....	5
6. ELECTRICAL WIRING.....	6
6.1. Electrical requirement.....	6
6.2. Wiring method.....	7
6.3. Unit wiring.....	7
6.4. Connection of wiring.....	7
6.5. Optional parts wiring.....	8
6.6. External input and external output (optional parts).....	9
6.7. IR receiver unit (optional parts).....	10
7. FIELD SETTING.....	10
7.1. Setting the address.....	10
7.2. Custom code setting.....	11
7.3. Function setting.....	11
8. FRESH AIR INTAKE.....	11
9. CASSETTE GRILLE INSTALLATION.....	12
10. TEST RUN.....	12
10.1. Test run using the outdoor unit (PCB).....	12
10.2. Test run using the remote controller.....	12
11. CHECK LIST.....	12
12. ERROR CODES.....	12

1. SAFETY PRECAUTIONS

- Be sure to read this manual thoroughly before installation.
- The warnings and precautions indicated in this manual contain important information pertaining to your safety. Be sure to observe them.
- Hand this manual, together with the operating manual to the customer. Request the customer to keep them on hand for future use, such as for relocating or repairing the unit.

 WARNING	This mark indicates procedures which, if improperly performed, might lead to the death or serious injury of the user.
Request your dealer or a professional installer to install the unit in accordance with this manual. An improperly installed unit can cause serious accidents such as water leakage, electric shock, or fire. If the unit is installed in disregard of the instructions in the installation manual, it will void the manufacturer's warranty.	
Do not turn ON the power until all work has been completed. Turning ON the power before the work is completed can cause serious accidents such as electric shock or fire.	
If refrigerant leaks while work is being carried out, ventilate the area. If the refrigerant comes in contact with a flame, it produces a toxic gas.	
Installation work must be performed in accordance with national wiring standards by authorized personnel only.	
Except for EMERGENCY, never turn off main as well as sub breaker of the indoor units during operation. It will cause compressor failure as well as water leakage. First, stop the indoor unit by operating the control unit, converter or external input device and then cut the breaker. Make sure to operate through the control unit, converter or external input device. When the breaker is designed, locate it at a place where the users cannot start and stop in the daily work.	

CAUTION

This mark indicates procedures which, if improperly performed, might possibly result in personal harm to the user, or damage to property.

Read carefully all security information before use or install the air conditioner.
Do not attempt to install the air conditioner or a part of the air conditioner by yourself.
This unit must be installed by qualified personnel with a capacity certificate for handling refrigerant fluids. Refer to regulation and laws in use on installation place.
The installation must be carried out in compliance with regulations in force in the place of installation and the installation instructions of the manufacturer.
This unit is part of a set constituting an air conditioner. It must not be installed alone or with non-authorized by the manufacturer.
Always use a separate power supply line protected by a circuit breaker operating on all wires with a distance between contact of 3 mm for this unit.
The unit must be correctly grounded and the supply line must be equipped with a differential breaker in order to protect the persons.
The units are not explosion proof and therefore should not be installed in explosive atmosphere.
Never touch electrical components immediately after the power supply has been turned off. Electric shock may occur. After turning off the power, always wait 5 minutes before touching electrical components.
This unit contains no user-serviceable parts. Always consult authorized service personnel to repairs.
When moving, consult authorized service personnel for disconnection and installation of the unit.

2. ABOUT THIS PRODUCT

2.1. Precautions for using the R410A refrigerant

WARNING

Do not introduce any substance other than the prescribed refrigerant into the refrigeration cycle. If air enters the refrigeration cycle, the pressure in the refrigeration cycle will become abnormally high and cause the piping to rupture.
If there is a refrigerant leakage, make sure that it does not exceed the concentration limit. If a refrigerant leakage exceeds the concentration limit, it can lead to accidents such as oxygen starvation.
Do not touch refrigerant that has leaked from the refrigerant pipe connections or other area. Touching the refrigerant directly can cause frostbite.
If a refrigerant leakage occurs during operation, immediately vacate the premises and thoroughly ventilate the area. If the refrigerant comes in contact with a flame, it produces a toxic gas.

2.2. Special tool for R410A

WARNING

To install a unit that uses the R410A refrigerant, use dedicated tools and piping materials that have been manufactured specifically for R410A use. Because the pressure of the R410A refrigerant is approximately 1.6 times higher than the R22, failure to use dedicated piping material or improper installation can cause rupture or injury. Furthermore, it can cause serious accidents such as water leakage, electric shock, or fire.

Tool name	Contents of change for R22 tool
Gauge manifold	Pressure is huge and cannot be measured with a conventional gauge. To prevent erroneous mixing of other refrigerants, the diameter of each port has been changed. It is recommended to use a gauge manifold with a high pressure display range -0.1 to 5.3 MPa and a low pressure display range -0.1 to 3.8 MPa.
Charging hose	To increase pressure resistance, the hose material and base size were changed.
Vacuum pump	A conventional vacuum pump can be used by installing a vacuum pump adapter. • A conventional vacuum pump can be used by installing a vacuum pump adapter. • Be sure that the pump oil does not back flow into the system. Use one capable for vacuum suction of -100.7kPa (5 Ton, -755mmHg).
Gas leakage detector	Special gas leakage detector for HFC refrigerant R410A.

2.3. Accessories

⚠ WARNING









For installation purposes, be sure to use the parts supplied by the manufacturer or other prescribed parts.

The use of non-prescribed parts can cause serious accidents such as the unit to fall, water leakage, electric shock, or fire.

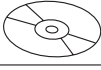
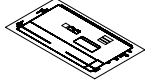
The following installation parts are furnished. Use them as required.

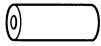
Keep the installation manual in a safe place and do not discard any other accessories until the installation work has been completed.

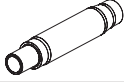
Do not discard any accessories needed for installation until the installation work has been completed.

Name and shape	Q'ty	Application
Operating manual 	1	
Installation manual 	1	(This book)
Operating manual (CD-ROM) 	1	
Template 	1	For ceiling openings cutting, also used as packing
Washer 	8	For installing indoor unit
Coupler heat insulation (large) 	1	For indoor side pipe joint (large pipe)
Coupler heat insulation (small) 	1	For indoor side pipe joint (small pipe)
Cable tie (large) 	4	For fixing the coupler heat insulation.
Cable tie (medium) 	2	For cable binding
Drain hose 	1	For installing drain pipe VP25 (O.D.32, I.D.25)
Hose band 	1	For installing drain hose
Drain hose insulation B 	1	Insulates the drain hose

2.4. Optional parts

Description	Model	Application
Cassette grille	UTG-UN*A-W	For AUXV004/007/009/012
	UTG-UN*B-W	For AUXV014/018/024
External connect kit	UTY-XWZXZC	For output function (Output terminal / CNB01)
	UTY-XWZXZB	For control input function (Apply voltage terminal / CNA01)
	UTY-XWZXZD	For control input function (Dry contact terminal / CNA02)
	UTY-XWZXZ7	For forced thermostat off function (Apply voltage terminal / CNA03)
	UTY-XWZXZE	For forced thermostat off function (Dry contact terminal / CNA04)
IR receiver unit	UTY-TRHX	For the wireless remote controller.
MODBUS® convertor	UTY-VMSX	For connecting to the Modbus network.
Wireless LAN adapter	UTY-TFSXZ*	For wireless LAN control.
External power supply unit	UTZ-GXXA	Supply power to the indoor unit PCB when the indoor unit is turned off to prevent errors.

3. INSTALLATION WORK

3.1. Selecting an installation location

Correct initial installation location is important because it is difficult to move unit after it is installed.

⚠ WARNING

Select installation locations that can properly support the weight of the indoor. Install the units securely so that they do not topple or fall.

⚠ CAUTION

Do not install the unit in the following areas:

- Area with high salt content, such as at the seaside. It will deteriorate metal parts, causing the parts to fail or the unit to leak water.
- Area filled with mineral oil or containing a large amount of splashed oil or steam, such as a kitchen. It will deteriorate plastic parts, causing the parts to fail or the unit to leak water.
- Area that generates substances that adversely affect the equipment, such as sulfuric gas, chlorine gas, acid, or alkali. It will cause the copper pipes and brazed joints to corrode, which can cause refrigerant leakage.
- Area that can cause combustible gas to leak, contains suspended carbon fibers or flammable dust, or volatile flammables such as paint thinner or gasoline. If gas leaks and settles around the unit, it can cause a fire.
- Area where animals may urinate on the unit or ammonia may be generated.

Do not use the unit for special purposes, such as storing food, raising animals, growing plants, or preserving precision devices or art objects. It can degrade the quality of the preserved or stored objects.

Do not install where there is the danger of combustible gas leakage.

Do not install the unit near a source of heat, steam, or flammable gas.

Install the unit where drainage does not cause any trouble.

Install the indoor unit, power supply cable, transmission cable, and remote controller cable at least 1 m away from a television or radio receivers. The purpose of this is to prevent TV reception interference or radio noise. (Even if they are installed more than 1 m apart, you could still receive noise under some signal conditions.)

If children under 10 years old may approach the unit, take preventive measures so that they cannot reach the unit.

Decide the mounting position with the customer as follows:

- (1) Install the indoor unit on a place having a sufficient strength so that it withstands against the weight of the indoor unit.
- (2) The inlet and outlet ports should not be obstructed; the air should be able to blow all over the room.
- (3) Leave the space required to service the air conditioner.
- (4) A place from where the air can be distributed evenly throughout the room by the unit.
- (5) Install the unit where connection to the outdoor unit (or RB unit) is easy.
- (6) Install the unit where the connection pipe can be easily installed.
- (7) Install the unit where the drain pipe can be easily installed.
- (8) Install the unit where noise and vibrations are not amplified.
- (9) Take servicing, etc., into consideration and leave the spaces. Also install the unit where the filter can be removed.

3.2. Preparation before installation

Remove the stays for transportation. Discard the stays and screws that you removed in this step.

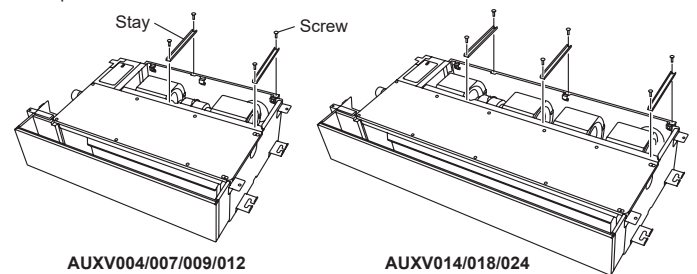

3.3. Installation dimensions

Provide a service access for inspection purposes.
Do not place any wiring or illumination in the service space, as they will impede service.

3.3.1. Installation dimensions

Front view

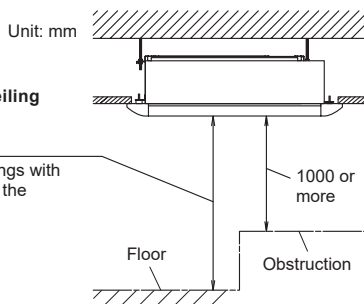
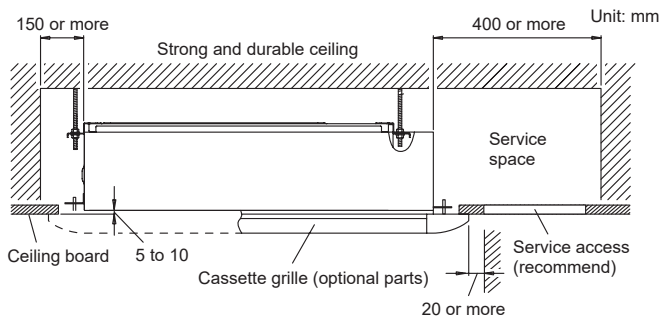

Maximum height from floor to ceiling

- Standard mode: 1800 to 2700
- High Ceiling mode: 1800 to 3200

* Be sure to make the function settings with the remote controller according to the installed ceiling height.

Right side view

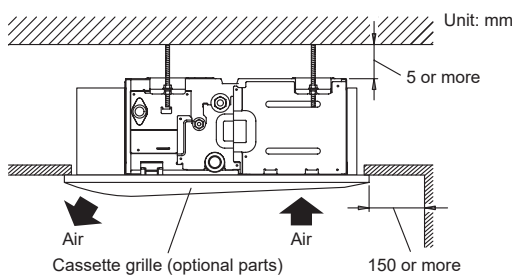

3.4. Installing the unit

WARNING

Install the air conditioner in a location which can withstand a load of at least 5 times the weight of the main unit and which will not amplify sound or vibration. If the installation location is not strong enough, the indoor unit may fall and cause injuries.

If the job is done with the panel frame only, there is a risk that the unit will come loose. Please take care.

- You can use the accessory template to help you install the indoor unit.
- The template helps you determine the appropriate locations for suspension bolts and pipe openings (drain pipe and connection cable).

3.4.1. Indoor unit dimensions

Top view

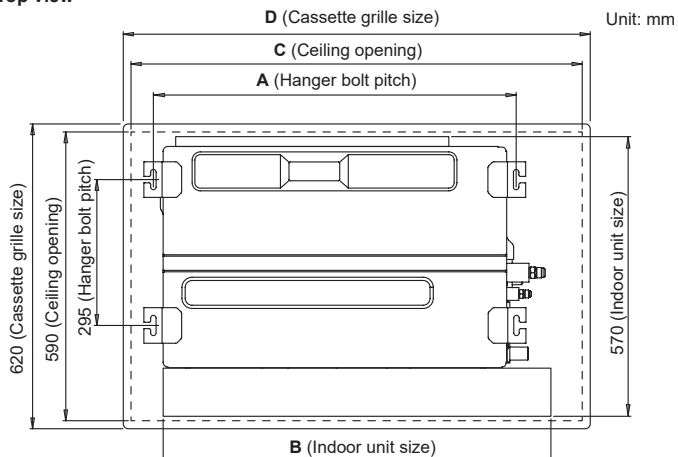

Model	AUXV004/007/009/012	AUXV014/018/024	
Dimensions	A:	752	1152
	B:	785	1190
	C:	920	1330
	D:	950	1360

Right side view

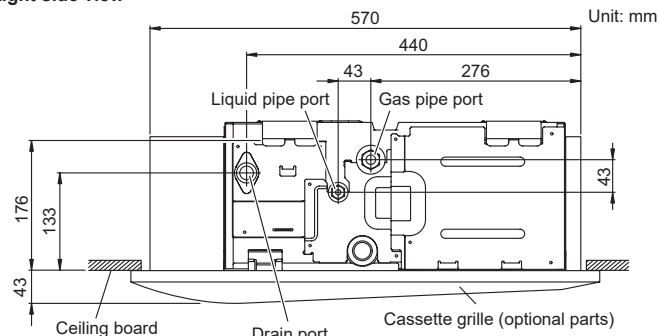

3.4.2. Fix the unit

CAUTION

Fasten the unit securely with nuts A and B.

(1) Hang the unit

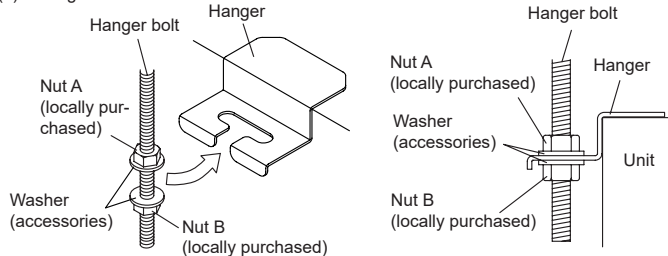

If the length of hanger bolt is over 20 mm, it will be not convenient for following works:

- The opening and closing of control box cover
- Replacement of drain pump

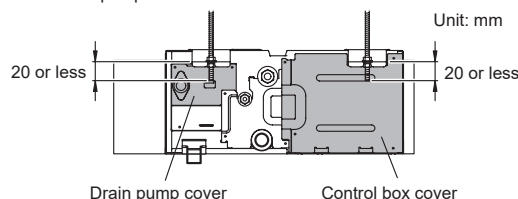

(2) Leveling

Base horizontal direction leveling on top of the unit.

Front view

Give a slight tilt to the drain port side. The tilt should be in the range of 0 mm to 10 mm.

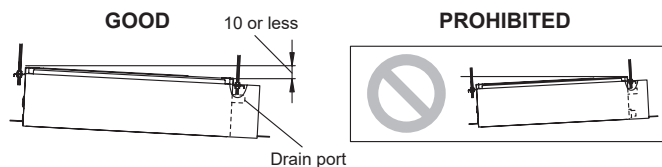
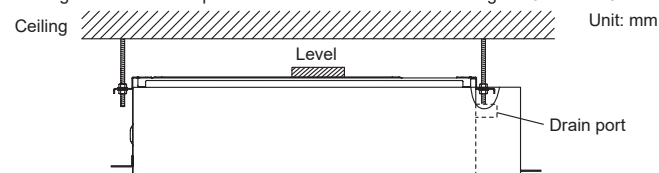

Right side view

Give a slight tilt to the rear side. The tilt should be in the range of 0 mm to 5 mm.

Unit: mm

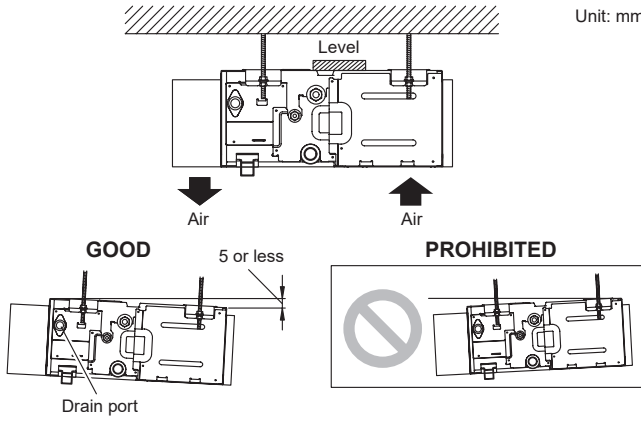

4. PIPE INSTALLATION

CAUTION

Be more careful that foreign matter (oil, water, etc.) does not enter the piping than with refrigerant R410A models. Also, when storing the piping, securely seal the openings by pinching, taping, etc.

While welding the pipes, be sure to blow dry nitrogen gas through them.

4.1. Selecting the pipe material

CAUTION

Do not use existing pipes from another refrigeration system or refrigerant.

Use pipes that have clean external and internal sides without any contamination which may cause trouble during use, such as sulfur, oxide, dust, cutting waste, oil, or water.

It is necessary to use seamless copper pipes.
Material: Phosphor deoxidized seamless copper pipes
It is desirable that the amount of residual oil is less than 40 mg/10 m.

Do not use copper pipes that have a collapsed, deformed, or discolored portion (especially on the interior surface). Otherwise, the expansion valve or capillary tube may become blocked with contaminants.

Improper pipe selection will degrade performance. As an air conditioner using R410A incurs pressure higher than when using conventional (R22) refrigerant, it is necessary to choose adequate materials.

- Thicknesses of copper pipes used with R410A are as shown in the table.
- Never use copper pipes thinner than those indicated in the table even if they are available on the market.

Thicknesses of Annealed Copper Pipes (R410A)

Pipe outside diameter [mm (in)]	Thickness [mm]
6.35 (1/4)	0.80
9.52 (3/8)	0.80
12.70 (1/2)	0.80
15.88 (5/8)	1.00
19.05 (3/4)	1.20

4.2. Pipe requirement

CAUTION

Refer to the installation manual of the outdoor unit for description of the length of connecting pipe or for difference of its elevation.

- Use pipe with water-resistant heat insulation.

CAUTION

Install heat insulation around both the gas and liquid pipes. Failure to do so may cause water leaks.

Use heat insulation with heat resistance above 120 °C. (Reverse cycle model only)
In addition, if the humidity level at the installation location of the refrigerant piping is expected to exceed 70 %, install heat insulation around the refrigerant piping. If the expected humidity level is 70 to 80 %, use heat insulation that is 15 mm or thicker and if the expected humidity exceeds 80 %, use heat insulation that is 20 mm or thicker. If heat insulation is used that is not as thick as specified, condensation may form on the surface of the insulation. In addition, use heat insulation with heat conductivity of 0.045 W/(m·K) or less (at 20 °C).

4.3. Flare connection (pipe connection)

WARNING

Tighten the flare nuts with a torque wrench using the specified tightening method. Otherwise, the flare nuts could break after a prolonged period, causing refrigerant to leak and generate hazardous gas if the refrigerant comes into contact with a flame.

4.3.1. Flaring

Use special flare tool exclusive for R410A.

- (1) Cut the connection pipe to the necessary length with a pipe cutter.
- (2) Hold the pipe downward so that cuttings will not enter the pipe and remove any burrs.
- (3) Insert the flare nut (always use the flare nut attached to the indoor and outdoor units (or RB unit) respectively) onto the pipe and perform the flare processing with a flare tool. Use the special R410A flare tool. Leakage of refrigerant may result if other flare nuts are used.
- (4) Protect the pipes by pinching them or with tape to prevent dust, dirt, or water from entering the pipes.

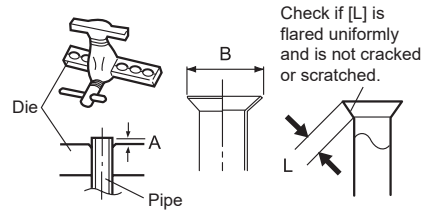

Pipe outside diameter [mm (in)]	Dimension A [mm] (Flare tool for R410A, clutch type)	Dimension B ± 0.4 [mm]
6.35 (1/4)	0 to 0.5	9.1
9.52 (3/8)		13.2
12.70 (1/2)		16.6
15.88 (5/8)		19.7
19.05 (3/4)		24.0

When using conventional (R22) flare tools to flare R410A pipes, the dimension A should be approximately 0.5 mm more than indicated in the table (for flaring with R410A flare tools) to achieve the specified flaring. Use a thickness gauge to measure the dimension A. It is recommended that a R410A flaring tool is used.

Pipe outside diameter [mm (in)]	Width across flats of flare nut [mm]
6.35 (1/4)	17
9.52 (3/8)	22
12.70 (1/2)	26
15.88 (5/8)	29
19.05 (3/4)	36

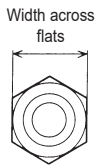

4.3.2. Bending pipes

- If pipes are shaped by hand, be careful not to collapse them.
- Do not bend the pipes in an angle more than 90°.
- When pipes are repeatedly bend or stretched, the material will harden, making it difficult to bend or stretch them anymore.
- Do not bend or stretch the pipes more than 3 times.

CAUTION

To prevent breaking of the pipe, avoid sharp bends.

If the pipe is bent repeatedly at the same place, it will break.

4.3.3. Pipe connection

CAUTION

Be sure to install the pipe against the port on the indoor unit correctly. If the centering is improper, the flare nut cannot tighten smoothly. If the flare nut is forced to turn, the threads will be damaged.

Do not remove the flare nut from the indoor unit pipe until immediately before connecting the connection pipe.

Hold the torque wrench at its grip, keeping it at a right angle with the pipe, in order to tighten the flare nut correctly.

Connect the piping so that the control box cover can easily be removed for servicing when necessary.

In order to prevent water from leaking into the control box, make sure that the piping is well insulated.

When the flare nut is tightened properly by your hand, hold the body side coupling with a separate spanner, then tighten with a torque wrench. (Refer to the following table for the flare nut tightening torques.)

Flare nut [mm (in)]	Tightening torque [N·m (kgf·cm)]
6.35 (1/4) dia.	16 to 18 (160 to 180)
9.52 (3/8) dia.	32 to 42 (320 to 420)
12.70 (1/2) dia.	49 to 61 (490 to 610)
15.88 (5/8) dia.	63 to 75 (630 to 750)
19.05 (3/4) dia.	90 to 110 (900 to 1,100)

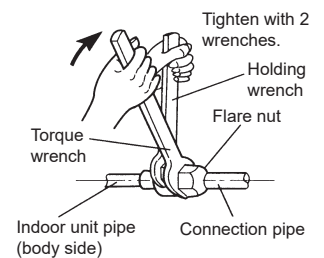

4.4. Installing heat insulation

Install the heat insulation material after performing a refrigerant leak check (refer to the installation manual for the outdoor unit for details).

4.4.1. Coupler heat insulation

- Insulate by the coupler heat insulation (accessories) around the gas pipe and liquid pipe of indoor side.
- After installing the coupler heat insulation, wrap both end with vinyl tape so that there is no gap.
- After affixing the coupler heat insulation, secure it with 2 cable ties (large), one on each end of the insulation.
- Make sure that the cable ties overlap the heat insulation pipe.

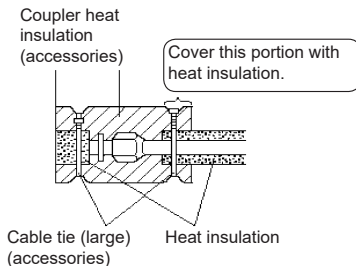

CAUTION

After checking for gas leaks (refer to the Installation Manual of the outdoor unit), perform this section.

Install heat insulation around both the large (gas) and small (liquid) pipes. Failure to do so may cause water leaks.

5. INSTALLING DRAIN PIPES

WARNING

Do not insert the drain piping into the sewer where sulfurous gas occurs. (Heat exchange erosion may occur)

Insulate the parts properly so that water will not drip from the connection parts.

Check for proper drainage after the construction by using the visible portion of transparent drain port and the drain piping final outlet on the body.

CAUTION

Do not apply adhesive agent on the drain port of the body. (Use the attached drain hose and connect the drain piping)

5.1. Drain piping

- Use general hard polyvinyl chloride pipe (VP25) [outside diameter 32 mm].
- Do not perform a rise, trap and air bleeding.
- Provide a downward gradient (1/100 or more).
- Provide supporters when long pipes are installed.
- Use an insulation material as needed, to prevent the pipes from freezing.
- Install the pipes in a way that allows for the removal of the control box.

GOOD

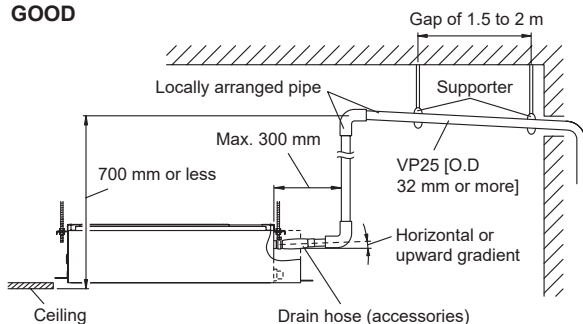

PROHIBITED

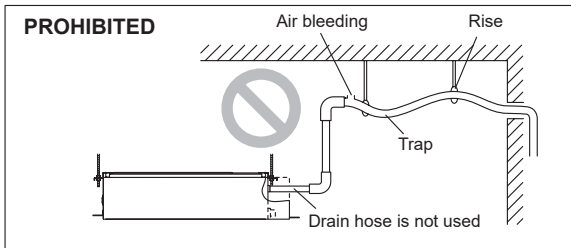

Observe the following procedures to construct centralized drain pipe fittings.

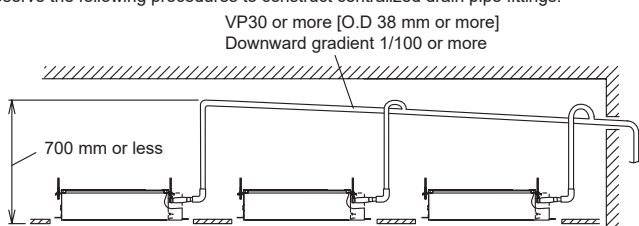

5.2. Install the drain pipe

CAUTION

Be sure to fix the drain hose to the drain port with the hose band. Do not apply glue to the drain port. Otherwise it will cause water leakage.

- (1) Be sure to use supplied drain hose (a) and hose band (b).

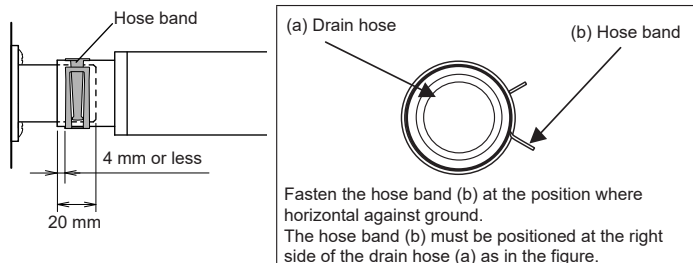
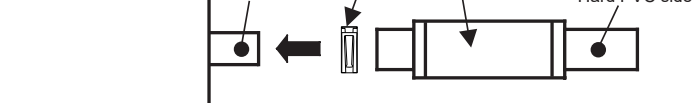

- (2) Be sure to connect Drain pipe with adhesive (polyvinyl chloride) so that there is no leakage.

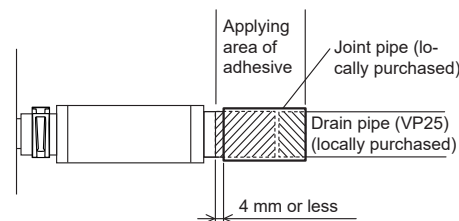

CAUTION

Do not connect to the drain hole with adhesive. Using adhesive may cause damage and water leaks.

- (3) After installing the drain hose (a), check if the drainage is smooth.

CAUTION

To prevent excessive force on drain hose (a), avoid bends or twists. (To bend or twist may cause water leaks.)

- (4) After checking for drainage, attach the drain hose insulation B (c) to insulate, following the instructions as in the figures.

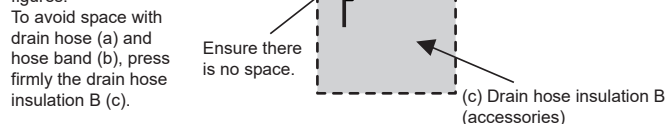

STEP1 - STEP3

Butt the insulation against the unit.

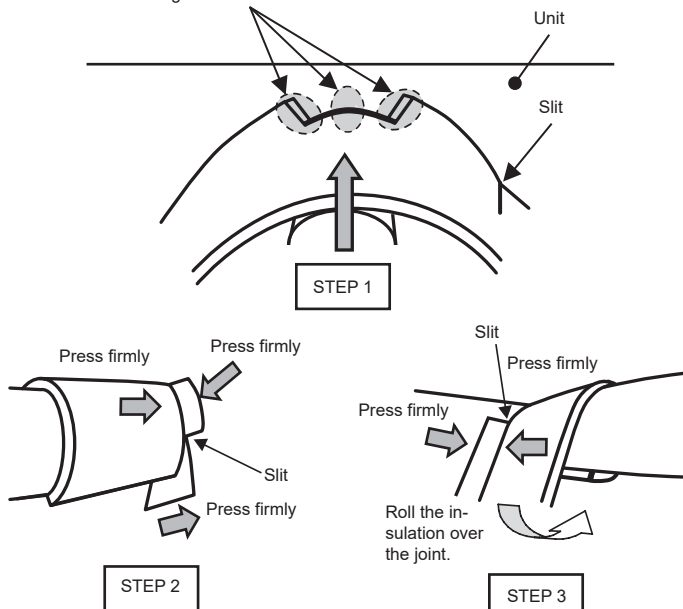

(5) Finish

Check that there is no gap between the unit and the drain hose insulation.

- When drain pump is used.

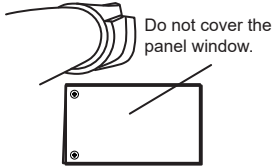

- When drain pump is not used. (Natural drainage)

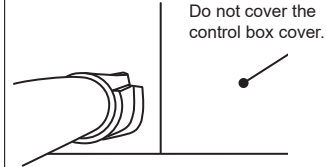

Check for drainage

Pour about 1 liter of water from the position shown in the diagram or from the airflow outlet to the dew tray. Check for any abnormalities such as strange noises and whether the drain pump functions normally.

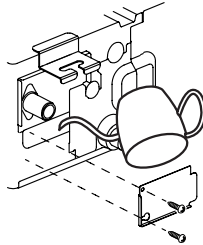

CAUTION

Make sure the drain water is properly drained.

6. ELECTRICAL WIRING

WARNING

Electrical work must be performed in accordance with this manual by a person certified under the national or regional regulations. Be sure to use a dedicated circuit for the unit. An insufficient power supply circuit or improperly performed electrical work can cause serious accidents such as electric shock or fire.

Before starting work, check that power is not being supplied to the all units.

For wiring, use the prescribed type of cables, connect them securely, making sure that there are no external forces of the cables applied to the terminal connections. Improperly connected or secured cables can cause serious accidents such as overheating the terminals, electric shock, or fire.

Securely install the electrical box cover on the unit. An improperly installed electrical box cover can cause serious accidents such as electric shock or fire through exposure to dust or water.

Install sleeves into any holes made in the walls for wiring. Otherwise, a short circuit could result.

Use the included connection cables and power cables or ones specified by the manufacturer. Improper connections, insufficient insulation, or exceeding the allowable current can cause electric shock or fire.

Do not modify the power cables, use extension cables, or use any branches in the wiring. Improper connections, insufficient insulation, or exceeding the allowable current can cause electric shock or fire.

Match the terminal block numbers and connection cable colors with those of the outdoor unit. Erroneous wiring may cause burning of the electric parts.

Securely connect the connection cables to the terminal board. In addition, secure the cables with wiring holders. Improper connections, either in the wiring or at the ends of the wiring, can cause a malfunction, electric shock, or fire.

Always fasten the outside covering of the connection cable with the cable clamp. (If the insulator is chafed, electric discharge may occur.)

Install an earth leakage breaker. In addition, install the earth leakage breaker so that the entire AC main power supply is cut off at the same time. Otherwise, electric shock or fire could result.

Always connect the earth (ground) cable. Improper earthing (grounding) work can cause electric shocks.

Install the remote controller cables so as not to be directly touched with your hand.

Perform wiring work in accordance with standards so that the air conditioner can be operated safely and positively.

Connect the connection cable firmly to the terminal board. Imperfect installation may cause a fire.

If the supply cable is damaged, it must be replaced by the manufacturer, its service agent or similarly qualified persons in order to avoid a hazard.

CAUTION

Earth (Ground) the unit. Do not connect the earth (ground) cable to a gas pipe, water pipe, lightning rod, or a telephone earth (ground) cable. Improper earthing (grounding) may cause electric shock.

Do not connect power supply cables to the transmission or remote controller terminals, as this will damage the product.

Never bundle the power supply cable and transmission cable, remote controller cable together. Separate these cables by 50 mm or more. Bundling these cables together will cause miss operation or breakdown.

When handling PCB, static electricity charged in the body may cause malfunction of the PCB. Follow the cautions below:

- Establish an earth (ground) for the indoor and outdoor units and peripheral devices.
- Cut power (breaker) off.
- Touch metal part of the indoor unit for more than 10 seconds to discharge static electricity charged in the body.
- Do not touch terminals of parts and patterns implemented on PCB.

6.1. Electrical requirement

- Select the power cable type and size in accordance with relevant local and national regulations.
- Specifications for local wiring power cord and branch wiring are in compliance with local code
- Max. wire length: Set a length so that the voltage drop is less than 2%. Increase the wire diameter when the wire length is long.

Voltage rating	230 V
Operating range	198 to 264 V (50 Hz) 198 to 253 V (60 Hz)

Breaker should be installed at every refrigerant system. Do not use a breaker in a different refrigerant system.

Refer to the table for the breaker specifications of each installation condition. Perform the power crossover wiring within the range of the same refrigerant system. When the crossover wiring is done, make a connection for indoor units to satisfy conditions A and B below.

A. Current breaker requirements

Model	MCA	MFA
AUXV004GLEH	0.34 A	20 A
AUXV007GLEH	0.38 A	
AUXV009GLEH	0.38 A	
AUXV012GLEH	0.56 A	
AUXV014GLEH	0.36 A	
AUXV018GLEH	0.51 A	
AUXV024GLEH	0.93 A	

MCA: Minimum Circuit Ampacity
MFA: Main Fuse Ampacity

When the power crossover wiring is done, make it so that the total of the MCA of the connected RB units and indoor units does not exceed the 15 A. For RB unit MCA, refer to the RB unit installation manual. If the capacity of connected RB units and indoor units exceeds the upper limit, either add breakers or use a breaker with a greater capacity.

B. Earth leakage breaker requirements

- 2 indoor units (including RB unit) = 1 All-direction airflow embedded type unit

Breaker capacity	Maximum connectable "indoor units" or "indoor units + RB units" (*1)
30 mA, 0.1 sec or less	44 or less
100 mA, 0.1 sec or less	45 to 148 (*2)

- *1: Heat pump type: indoor units, Heat recovery type: indoor units and RB units.
- *2: If the 100 mA capacity breaker is not provided, split the quantity of the indoor units into small groups of 9 units or less and provide a breaker with capacity of 30 mA for each group.

6.1.1. Cable specifications

Follow the specifications below for the power supply, transmission and remote controller cable.

	Recommended cable size (mm ²)	Cable type	Remark
Power supply cable	2.5	Type 60245 IEC57 or equivalent	2 Cable + earth (ground)
Transmission cable	0.33	LONWORKS® compatible cable	22 AWG LEVEL 4 (NEMA) non-polar 2 core, twisted pair solid core diameter 0.65 mm
Remote controller cable (2-wire type)	0.33 to 1.25	Sheathed PVC cable (*1)	Non-polar 2 core, twisted pair

*1: Use shielded cable in accordance with local rules for remote controller cable.

6.2. Wiring method

Example

Outdoor unit or RB unit *1

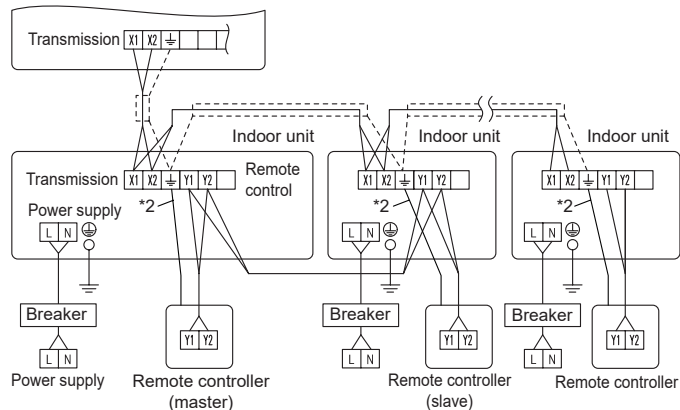

*1: When connecting to the Heat Recovery System, refer to the installation manual of the RB unit.

*2: Earth (Ground) the remote controller if it has an earth (ground) cable.

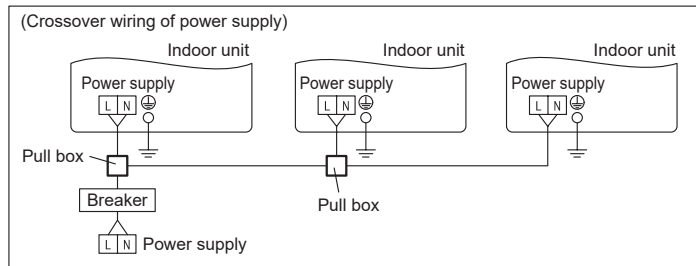

6.3. Unit wiring

Before attaching the cable to terminal block.

6.3.1. Cable specifications

Adjust the length of power supply cable to avoid excessive tension with referring figure below.

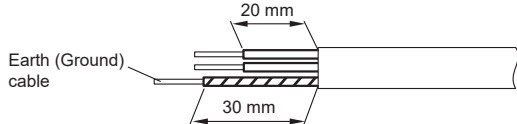

A. For solid core wiring

- To connect the electrical terminal, follow the below diagram and connect after looping it around the end of the cable.
- Use the specified cables, connect them securely, and fasten them so that there is no stress placed on the terminals.
- Use an appropriate screwdriver to tighten the terminal screws. Do not use a screwdriver that is too small, otherwise, the screw heads may be damaged and prevent the screws from being properly tightened.
- Do not tighten the terminal screws too much, otherwise, the screws may break.
- Refer to the table for the terminal screw tightening torques.
- Please do not fix 2 power supply cables with 1 screw.

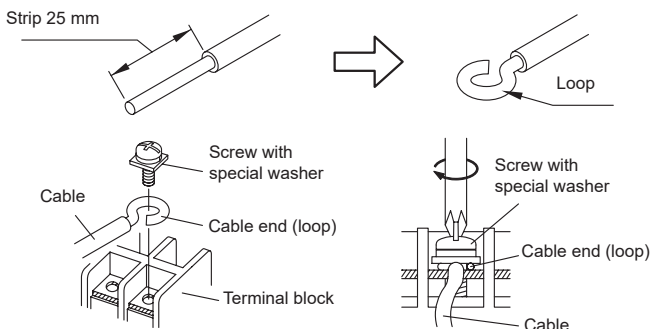

Do not apply branch wiring. It may result electric shock or fire.

WARNING

When using solid core cables, do not use the ring terminal. If you use the solid core cables with the ring terminal, the ring terminal's pressure bonding may malfunction and cause the cables to abnormally heat up.

B. For strand wiring

- Use ring terminals with insulating sleeves as shown in the figure below to connect to the terminal block.
- Securely clamp the ring terminals to the cables using an appropriate tool so that the cables do not come loose.
- Use the specified cables, connect them securely, and fasten them so that there is no stress placed on the terminals.
- Use an appropriate screwdriver to tighten the terminal screws. Do not use a screwdriver that is too small, otherwise, the screw heads may be damaged and prevent the screws from being properly tightened.
- Do not tighten the terminal screws too much, otherwise, the screws may break.
- Refer to the table for the terminal screw tightening torques.
- Please do not fix 2 power supply cables with 1 screw.

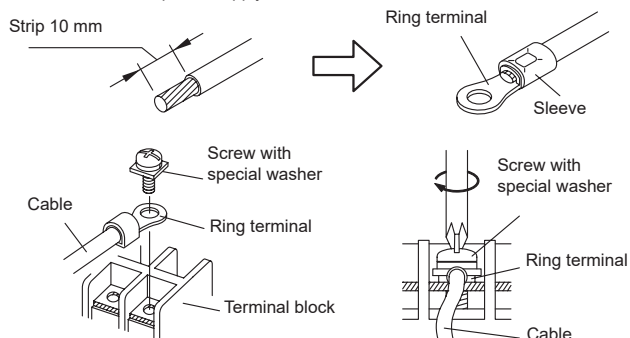

WARNING

Use ring terminals and tighten the terminal screws to the specified torques, otherwise, abnormal overheating may be produced and possibly cause heavy damage inside the unit.

Tightening torque

M4 screw (Power supply/L, N, GND)	1.2 to 1.8 N·m (12 to 18 kgf·cm)
-----------------------------------	----------------------------------

6.3.2. Transmission and Remote controller cable

Transmission cable

Remote controller cable

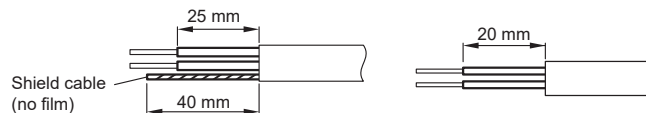

- Connect remote controller and transmission cables as shown in following figure.

GOOD

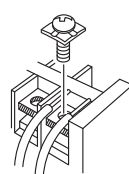

PROHIBITED

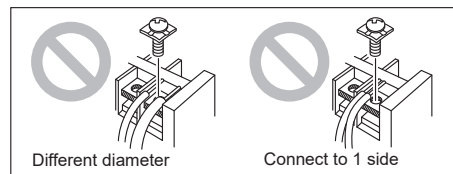

WARNING

Tighten the terminal screws to the specified torques, otherwise, abnormal overheating may be produced and possibly cause heavy damage inside the unit.

Terminal number

Tightening torque

M3 screw (Transmission/X1, X2) (Remote controller/ Y1, Y2)	0.5 to 0.6 N·m (5 to 6 kgf·cm)
---	-----------------------------------

CAUTION

To peel the film from the lead cable, use a dedicated tool that will not damage the conductor cable.

When installing a screw on the terminal block, do not cut the cable by overtightening the screw. On the other hand, an undertightened screw can cause faulty contact, which will lead to a communication failure.

6.4. Connection of wiring

- Remove the control box cover.

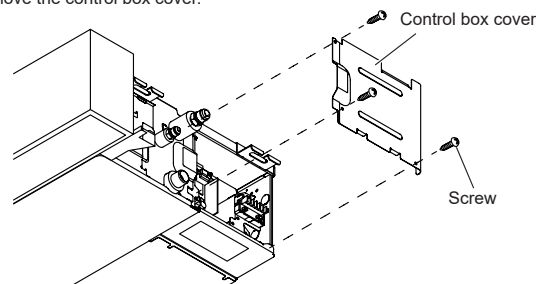

(2) Connect the connection cable.

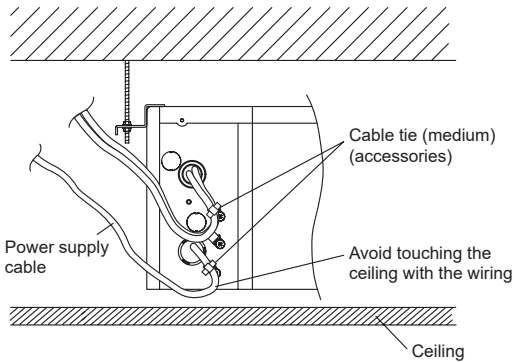
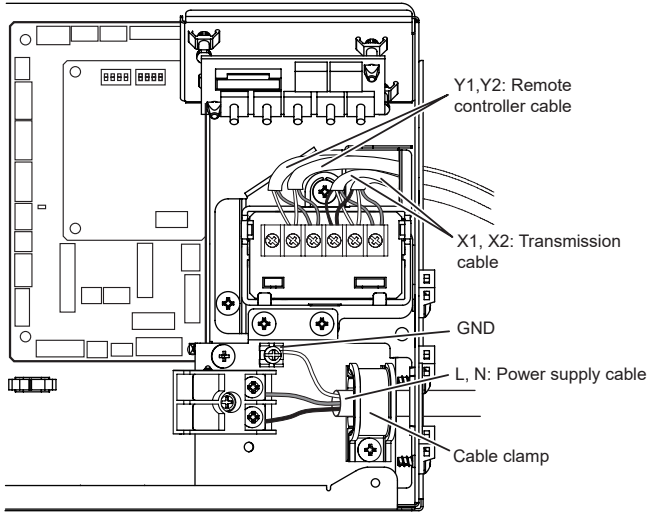

Do not bind the power supply cable and other cables together.

6.5. Optional parts wiring

6.5.1. Layout of the indoor unit PCB

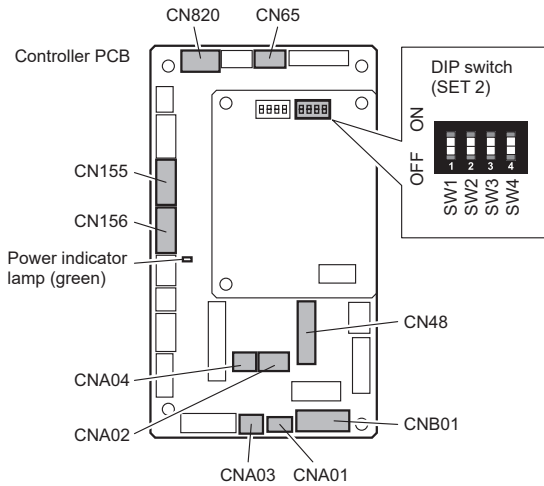

Name	Application	
Power indicator lamp (green)	Indicates the state of the power supply. Refer to "Power indicator lamp status" following.	
CNA01	Apply voltage terminal	For external input
CNA03		
CNA02	Dry contact terminal	
CNA04		
DIP switch SET 2 (SW2)	Input signal type switching	
CNB01	Output terminal	For external output
CN48	For IR receiver unit (*1)	
CN65	For one of the following. • MODBUS® convertor (*1) • Wireless LAN adapter (*1)	
CN155	For Cassette grille (*1)	
CN156		
CN820	For External power supply unit (*1)	

*1: For details, refer to each installation manual.

6.5.2. Power indicator lamp status

Power indicator lamp (Green)	Status contents
○ Lit	Lit when the power is turned on.
● Fast flashing (every 0.1 second)	There is a fault with the communication board or the main board.
● Blinking (repeat 3 seconds ON and 1 second OFF)	The indoor unit is turned off and power is supplied from the External power supply unit (optional) to the indoor unit PCB.

6.5.3. Connection methods

Wire modification for External input/output wire

- Remove insulation from wire attached to wire kit connector.
- Remove insulation from field supplied cable. Use crimp type insulated butt connector to join field cable and wire kit wire.
- Connect the wire with connecting wire with solder.

IMPORTANT:

Be sure to insulate the connection between the wires.

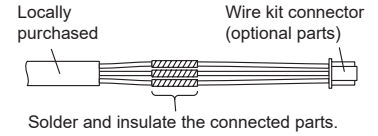

Wiring arrangement

In following figure, all the possible connectors are connected for description. In actual installation, you cannot connect all the connectors at once.

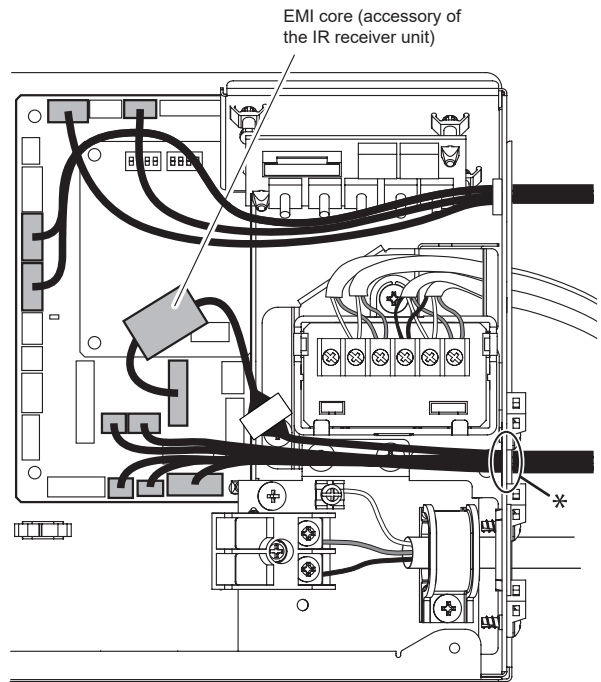

* CAUTION

To protect the cable insulation after opening a knockout hole, remove any burrs from the edge of the hole.

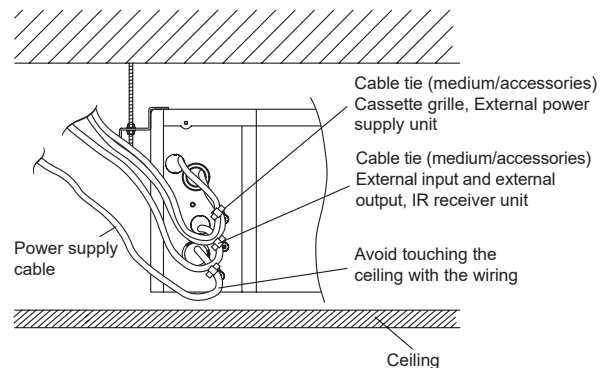

Do not bind the power supply cable and other cables together.

6.6. External input and external output (optional parts)

6.6.1. External input

- Indoor unit can be operation/stop, emergency stop or forced stop by using indoor unit PCB CNA01 or CNA02.
- “Operation/Stop” mode, “Emergency stop” mode or “Forced stop” mode can be selected with function setting of indoor unit.
- Indoor unit can be forced thermostat off by using indoor unit PCB CNA03 or CNA04.
- A twisted pair cable (22 AWG) should be used. Maximum length of cable is 150 m.
- Use an external input and output cable with appropriate external dimension, depending on the number of cables to be installed.
- The wire connection should be separate from the power cable line.

Input select

Use either one of these types of terminal according to the application. (Both types of terminals cannot be used simultaneously.)

• Apply voltage terminal ([CNA01], [CNA03])

When a power supply must be provided at the input device you want to connect, use the apply voltage terminal ([CNA01], [CNA03]).

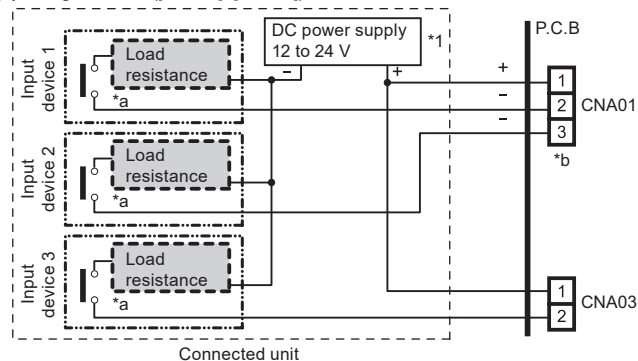

- *1: Make the power supply DC 12 to 24 V. Select a power supply capacity with an ample surplus for the connected load. Do not impress a voltage exceeding 24 V across pins 1-2, and 1-3.
- *a: The allowable current is DC 5 mA to 10 mA. (Recommended: DC 5 mA) Provide a low resistance such that the current becomes DC 10 mA or less. Select very low current use contacts (usable at DC 12 V, DC 1 mA or less).
- *b: The polarity is [+] for pin 1 and [-] for pin 2 and 3. Connect correctly.

When connected to apply voltage terminals of multiple indoor units with a connected unit, be sure to make a branch outside the indoor unit using a pull box, etc. as shown on below example.

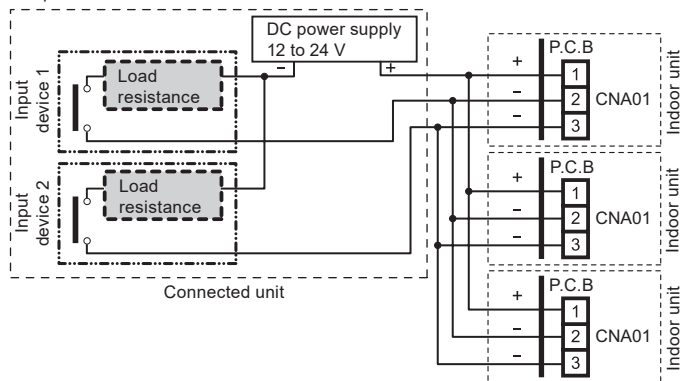

• Dry contact terminal ([CNA02], [CNA04])

When a power supply is unnecessary at the input device you want to connect, use the dry contact terminal ([CNA02], [CNA04]).

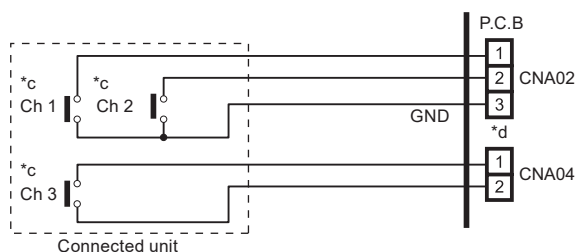

- *c: Select very low current use contacts (usable at DC 12 V, DC 1 mA or less).
- *d: The wiring is different from apply voltage terminals. Be sufficiently careful when wiring.

When connected to dry contact terminals of multiple indoor units with a connected unit, insulate each indoor unit with relay, etc. as shown on below example.

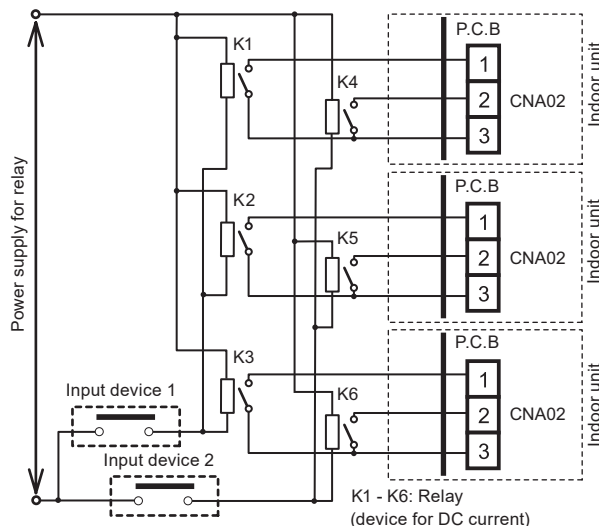

NOTE:

When connected to multiple indoor units directly, it will cause breakdown.

Operation behavior

• Input signal type

The input signal type can be selected. It is switched by DIP switch on the indoor unit PCB.

DIP switch [Set 2 SW2]	Input signal type
OFF (factory setting)	Edge
ON	Pulse

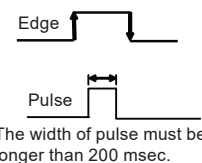

• When function setting is “Operation/Stop” mode.

Input signal type	Connector	Input signal	Command
Edge	Ch1 of CNA01 or CNA02	OFF → ON	Operation
		ON → OFF	Stop
Pulse	CNA01 or CNA02	Ch1: OFF → ON	Operation
		Ch2: OFF → ON	Stop

* The last command has priority.

* The indoor units within the same remote controller group operates in the same mode.

• When function setting is “Emergency stop” mode.

Input signal type	Connector	Input signal	Command
Edge	Ch1 of CNA01 or CNA02	OFF → ON	Emergency stop
		ON → OFF	Normal
Pulse	CNA01 or CNA02	Ch1: OFF → ON	Emergency stop
		Ch2: OFF → ON	Normal

* All indoor units of same refrigerant system stops when emergency stop operates.

• When function setting is “Forced stop” mode.

Input signal type	Connector	Input signal	Command
Edge	Ch1 of CNA01 or CNA02	OFF → ON	Forced stop
		ON → OFF	Normal
Pulse	CNA01 or CNA02	Ch1: OFF → ON	Forced stop
		Ch2: OFF → ON	Normal

* When the forced stop is triggered, indoor unit stops and operation/stop operation by a remote controller is restricted.

* When forced stop function is used with forming a remote controller group, connect the same equipment to each indoor unit within the group.

• Selection method of functions

“Operation/Stop” mode or “Emergency stop” mode, “Forced stop” mode can be selected with function setting of indoor unit.

• Forced thermostat off function

[“Edge” input only]

Function setting	Connector	Input signal	Command
60-00	Ch3 of CNA03 or CNA04	OFF → ON	Thermostat off
		ON → OFF	Normal

• Refrigerant leak detection function (only for J-III series)

[“Edge” input only]

Function setting	Connector	Input signal	Command
60-09	Ch3 of CNA03 or CNA04	OFF → ON	No command
		ON → OFF	Refrigerant leak

6.6.2. External output

- A twisted pair cable (22AWG) should be used. Maximum length of cable is 25 m.
- Use an external input and output cable with appropriate external dimension, depending on the number of cables to be installed.
- Output voltage: Hi DC 12 V \pm 2 V, Lo 0 V.
- Permissible current: 50 mA

Output select

- When indicator etc. are connected directly

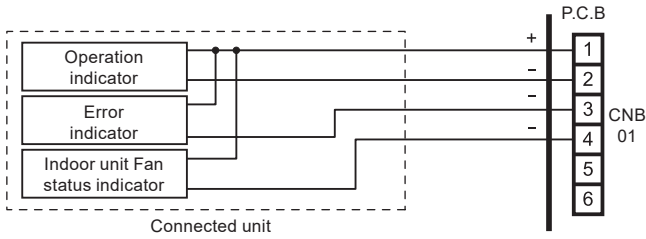

- When connecting with unit equipped with a power supply

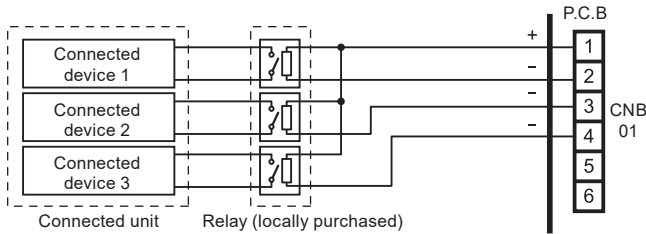

Operation behavior

Connector		Output voltage	Status
CNB01	External output 1 Pins 1-2	0 V	Stop
		DC 12 V	Operation
	External output 2 Pins 1-3	0 V	Normal
		DC 12 V	Error
	External output 3 Pins 1-4	0 V	Indoor unit fan stop
		DC 12 V	Indoor unit fan operation

6.7. IR receiver unit (optional parts)

Connection method

- For the installation method, please refer to the installation manual of IR receiver unit.
- (1) Use 9 pins for receiver unit cable.
 - (2) At first, connect the receiver unit cable to the controller PCB.
 - (3) Attach the core that comes between controller PCB and the clamp.
 - (4) Use conduit hole when external output cable is used.

7. FIELD SETTING

There are 3 methods for address setting by field setting as follows. Set by either of the methods.

Each setting method is described (1) to (3) below.

(1) IU AD, REF AD SW settings	This section ("7.1. Setting the address")
(2) Remote controller settings	Refer to the wired or wireless remote controller manual for detailed setting information. (Set IU AD, REF AD SW to 0)
(3) Automatic address settings	Refer to the outdoor unit manual for detailed setting information. (Set IU AD, REF AD SW to 0)

CAUTION

Be sure to turn OFF the power before performing the field setting.

7.1. Setting the address

7.1.1. Manual address setting method

- If the receiver unit is attached, the indoor unit address and the refrigerant circuit address can also be set up through the wireless remote controller.

CAUTION

Use an insulated screwdriver to set the DIP switches.

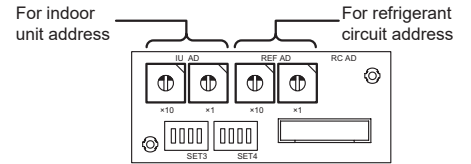

Indoor unit address	<ul style="list-style-type: none"> • Rotary switch (IU AD \times 1)...Factory setting "0" • Rotary switch (IU AD \times 10)...Factory setting "0" <p>When connecting multiple indoor units to 1 refrigerant system, set the address at IU AD SW as shown in the table A.</p>
Refrigerant circuit address	<ul style="list-style-type: none"> • Rotary switch (REF AD \times 1)...Factory setting "0" • Rotary switch (REF AD \times 10)...Factory setting "0" <p>In the case of multiple refrigerant systems, set REF AD SW as shown in the table A for each refrigerant system. Set to the same refrigerant circuit address as the outdoor unit.</p>





- If working in an environment where the wireless remote controller can be used, the addresses can also be set using the remote controller.
- If setting the addresses using the wireless remote controller, set the indoor unit address and refrigerant circuit address to "00". (For information on setting using the wireless remote controller.)

- * Do not set the indoor unit address (IU AD SW) at 64 to 99. It may result in failure.

Table A

Refrigerant circuit	Rotary switch setting		Address	Rotary switch setting	
	REF AD SW \times 10	\times 1		Indoor unit	IU AD SW \times 10
0	0	0	0	0	0
1	0	1	1	0	1
2	0	2	2	0	2
3	0	3	3	0	3
4	0	4	4	0	4
5	0	5	5	0	5
...
10	1	0	10	1	0
11	1	1	11	1	1
...
99	9	9	63	6	3

Setting example

Setting	Setting range	Type of switch
Indoor unit address	0 to 63	Setting example 2  IU AD \times 10  IU AD \times 1
Refrigerant circuit address	0 to 99	Setting example 63  REF AD \times 10  REF AD \times 1

7.2. Custom code setting

Selecting the custom code prevents the indoor unit mix-up.
(Up to 4 codes can be set.)

Perform the setting for both the indoor unit and the remote controller.

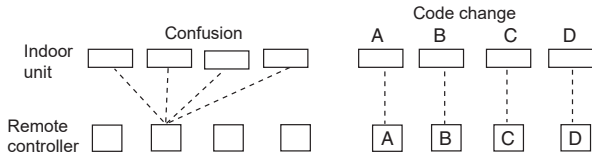

Setting method

Set the DIP switch SET 3 SW1, SW2, referring to the following table.

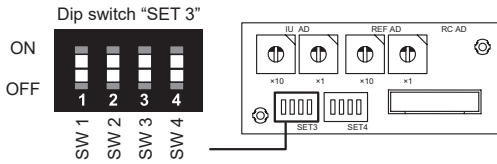

	Custom code			
	A (factory setting)	B	C	D
DIP switch SET3 SW1	OFF	ON	OFF	ON
DIP switch SET3 SW2	OFF	OFF	ON	ON

7.3. Function setting

- Function setting can be performed with the wired or wireless remote controller. (The remote controller is optional equipment)
- Refer to the wired or wireless remote controller manual for detailed setting information.
- Refer to "7.1. Setting the address" for indoor unit address and refrigerant circuit address settings.
- Turn the power of the indoor unit ON before starting the setting.
- * Turning on the power to the indoor units initializes EEV, so make sure the piping air tight test and vacuuming have been conducted before turning on the power.
- * Also check again to make sure no wiring mistakes were made before turning on the power.

Function details

Function	Function number	Setting number	Default	Details
Filter indicator interval	11	00 Standard	○	Adjust the filter cleaning interval notification. If the notification is too early, change to setting 01. If the notification is too late, change to setting 02.
		01 Longer		
		02 Shorter		
Filter indicator action	13	00 Enable	○	Enable or disable the filter indicator. Setting 02 is for use with a central remote controller.
		01 Disable		
		02 Display only on central remote controller		
Ceiling airflow	20	00 Standard	○	Regulate the airflow according to the needs of the installation location. When set to 01, the airflow will be stronger.
		01 High ceiling		
(Forbidden)	23	00	○	
(Forbidden)	24	00	○	
(Forbidden)	26	00	○	
(Forbidden)	27	00	○	
Cool air temperature trigger	30	00 Standard	○	Adjust the cool air trigger temperature. To lower the trigger temperature, use setting 01. To raise the trigger temperature, use setting 02.
		01 Adjust (1)		
		02 Adjust (2)		
Heat air temperature trigger	31	00 Standard	○	Adjust the heat air trigger temperature. To lower the trigger temperature by 6 degrees C, use setting 01. To lower the trigger temperature by 4 degrees C, use setting 02. To raise the trigger temperature, use setting 03.
		01 Adjust (1)		
		02 Adjust (2)		
Auto restart	40	00 Enable	○	Enable or disable automatic system restart after a power outage.
		01 Disable		
		02 Super low	○	
Cool Air Prevention	43	00 Follow the setting on the remote controller		Restraining the cold airflow with making the airflow lower when starting heating operation. To correspond to the ventilation, set to 01.
		01		
External control	46	00 Start/Stop	○	Allow an external controller to start or stop the system, or to perform an emergency stop. * If an emergency stop is performed from an external controller, all refrigerant systems will be disabled. * If forced stop is set, indoor unit stops by the input to the external input terminals, and Start/Stop by a remote controller is restricted.
		01 Emergency stop		
		02 Forced stop		
Error report target	47	00 All	○	Change the target for reporting errors. Errors can either be reported in all locations, or only on the central remote controller.
		01 Display only on central remote controller		

Function	Function number	Setting number	Default	Details
Fan setting when cooling thermostat OFF	49	00 Follow the setting on the remote controller	○	When set to 01, the fan stops when the thermostat is OFF in cooling operation. Connection of the wired remote controller (2-wire type or 3-wire type) and switching its thermostat are necessary.
		01 Stop		
Switching function for external inputs	60	00 Forced thermostat off	○	Setting is required when connecting a refrigerant-leak detecting device. (only for J-III series)
		01		
		02		
		03		
		04 (Forbidden)		
		05		
		06		
		07		
		08		
(Forbidden)	61	00	○	
(Forbidden)	62	00	○	
Auto mode type	68	00 Single setpoint auto mode (traditional)	○	Switch the setting method of auto mode to single or dual (cooling/heating). For heat pump systems, it is necessary to set the master indoor unit (by wired remote controller).
		01 Dual setpoint auto mode		
Deadband value	69	00 0°C	○	Choose the minimum temperature between cooling and heating settings (deadband) for Dual setpoint auto mode (set in No. 68).
		01 0.5°C		
		02 1.0°C		
		03 1.5°C		
		04 2.0°C		
		05 2.5°C		
		06 3.0°C		
		07 3.5°C		
		08 4.0°C		
09 4.5°C				
(Forbidden)	70	00	○	
(Forbidden)	72	00	○	
(Forbidden)	73	00	○	
(Forbidden)	74	00	○	
(Forbidden)	75	00	○	

8. FRESH AIR INTAKE

- Open the fresh air intake port.
- Fasten the round flange (locally purchased) to the fresh air intake port.

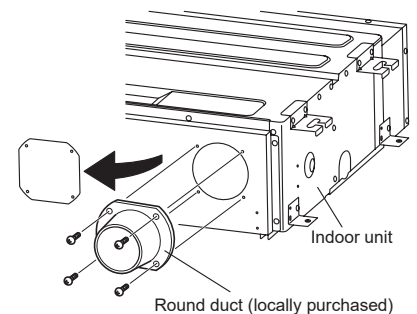

[After completing "3.4. Installing the unit"...]

- Connect the duct to the round flange.
- Seal with a band and vinyl tape, etc. so that air does not leak from the connection.

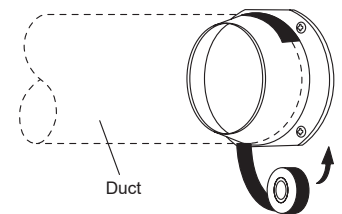

9. CASSETTE GRILLE INSTALLATION

- Operate according to the installation manual of the Cassette grille.
- Be sure to confirm there is no gap between the Cassette grille and main unit after installing the Cassette grille.

10. TEST RUN

10.1. Test run using the outdoor unit (PCB)

- Refer to the installation manual for the outdoor unit if the PCB for the outdoor unit is to be used for the test run.

10.2. Test run using the remote controller

- Refer to the installation manual for the remote controller to perform the test run using the wireless remote controller.
- When the air conditioner is being test run, the OPERATION and TIMER indicators flash slowly at the same time.

11. CHECK LIST

Pay special attention to the check items below when installing the indoor unit(s). After installation is complete, be sure to check the following check items again.

CHECK ITEMS	If not performed correctly	CHECK BOX
Has the indoor unit been installed correctly?	Vibration, noise, indoor unit may drop	
Has there been a check for gas leaks (refrigerant pipes)?	No cooling, No heating	
Has heat insulation work been completed?	Water leakage	
Does water drain easily from the indoor units?	Water leakage	
Is the voltage of the power source the same as that indicated on the label on the indoor unit?	No operation, heat or burn damage	
Are the wires and pipes all connected completely?	No operation, heat or burn damage	
Is the indoor unit earthed (grounded)?	Short circuit	
Is the connection cable the specified thickness?	No operation, heat or burn damage	
Are the inlets and outlets free of any obstacles?	No cooling, No heating	
Does start and stop air conditioner operation by remote controller or external device?	No operation	
After installation is completed, has the proper operation and handling been explained to the user?		

12. ERROR CODES

If you use a wired type remote controller, error codes will appear on the remote controller display. If you use a wireless remote controller, the lamp on the photodetector unit will output error codes by way of blinking patterns. Refer to the following table for lamp blinking patterns and error codes.

Error indications			Wired remote controller error code	Error contents
OPERATION lamp (green)	TIMER lamp (orange)	FILTER lamp (red)		
● (1)	● (2)	◇	12	Remote controller communication error
● (1)	● (4)	◇	14	Network communication error
● (1)	● (6)	◇	16	Peripheral unit communication error
● (2)	● (6)	◇	26	Indoor unit address setting error
● (2)	● (9)	◇	29	Connection unit number error in wired remote controller system
● (3)	● (1)	◇	31	Indoor unit power supply abnormal
● (3)	● (2)	◇	32	Indoor unit main PCB error
● (3)	● (10)	◇	3A	Indoor unit communication circuit (wired remote controller) error
● (4)	● (1)	◇	41	Indoor unit room temp. thermistor error
● (4)	● (2)	◇	42	Indoor unit heat ex. temp. thermistor error
● (5)	● (1)	◇	51	Indoor unit fan motor 1 error
● (5)	● (2)	◇	52	Indoor unit coil (expansion valve) error
● (5)	● (3)	◇	53	Indoor unit water drain abnormal
● (9)	● (15)	◇	9U	Outdoor unit miscellaneous error
● (10)	● (8)	◇	AB	Poor refrigerant circulation
● (13)	● (1)	◇	J1	RB unit error

Display mode ● : 0.5 s ON / 0.5 s OFF
 ◇ : 0.1 s ON / 0.1 s OFF
 () : Number of flashing

Wired Remote Controller Display

UTY-RNR*Z* (2-wire type)

Touch the [Status]. Touch the [Error Information].

2-digit numbers are corresponding to the error code in the preceding table. Error Code [14, 16]

For more information, refer to the installation manual of the remote controller.

UTY-RLR* (2-wire type)

Error code

For more information, refer to the installation manual of the remote controller.

For details on marking the error codes, please refer to the manual of "IR receiver unit" or "Wired remote controller".