

## 3-4. Refrigerant circuit

### ■ Symbol description

Mark	Description
SV1 (D1)	Solenoid valve (Discharge 1)
SV2 (B2)	Solenoid valve (Bypass 2)
SV3 (B1)	Solenoid valve (Bypass 1)
SV4 (S1)	Solenoid valve (Suction 1)
SV5 (S2)	Solenoid valve (Suction 2)
SV6 (S3)	Solenoid valve (Suction 3)

### ■ Model: UTP-RX01AH

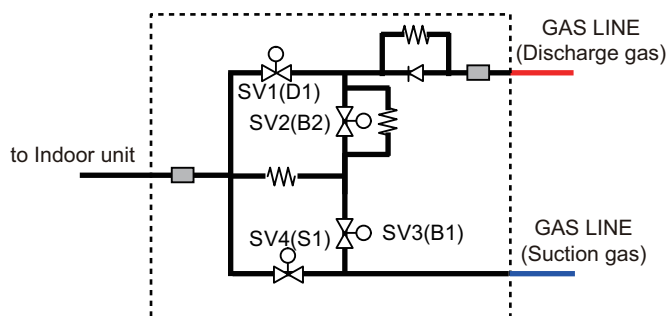

### ■ Model: UTP-RX01BH

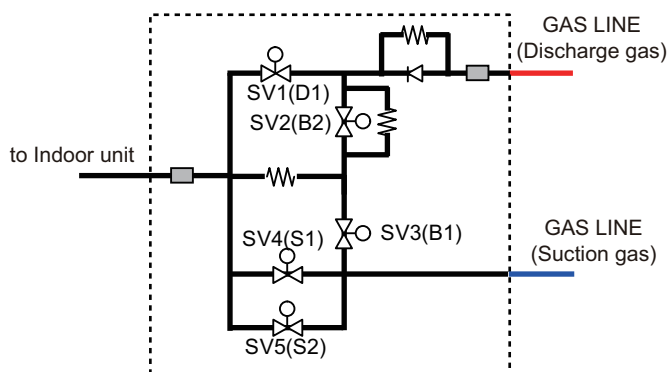

### ■ Model: UTP-RX01CH

