

UTY-DTGYZ1  
UTY-DTGGZ1

富士通将军有限公司  
FUJITSU GENERAL LIMITED

## INSTALLATION MANUAL

TOUCH PANEL CONTROLLER  
For authorized service personnel only.

English

## INSTALLATIONSANLEITUNG

SENSORBILDSCHIRMSTEUERUNG  
Nur für autorisiertes Fachpersonal.

Deutsch

## MANUEL D'INSTALLATION

CONTRÔLEUR DE PANNEAU À CONTACT  
Pour le personnel agréé uniquement.

Français

## MANUAL DE INSTALACIÓN

CONTROLADOR DE PANEL DE CONTACTO  
Únicamente para personal de servicio autorizado.

Español

## MANUALE DI INSTALLAZIONE

DISPOSITIVO DI CONTROLLO DI PANNELLO A CONTATTO  
A uso esclusivo del personale tecnico autorizzato.

Italiano

## ΕΓΧΕΙΡΙΔΙΟ ΕΓΚΑΤΑΣΤΑΣΗΣ

ΘΘΟΝΗ ΑΦΗΣ ΧΕΙΡΙΣΜΟΥ  
Μόνο για εξουσιοδοτημένο τεχνικό προσωπικό.

Ελληνικά

## MANUAL DE INSTALAÇÃO

CONTROLADOR DE PAINEL DE TOQUE  
Apenas para técnicos autorizados.

Português

## РУКОВОДСТВО ПО УСТАНОВКЕ

КОНТРОЛЛЕР С СЕНСОРНОЙ ПАНЕЛЬЮ  
Только для авторизованного обслуживающего персонала.

Русский

## MONTAJ KILAVUZU

DOKUNMATİK PANELLİ KUMANDA  
Yalnızca yetkili servis personeli için.

Türkçe

## 安装说明书

触摸屏控制器  
仅针对授权的专业维修人员。

中文

[Original instructions]



PART NO. 9378850033-03

# INSTALLATION MANUAL

PART NO. 9378850033-03  
TOUCH PANEL CONTROLLER

## Contents

|  |   |
|--|---|
| 1. SAFETY PRECAUTIONS .....                    | 1 |
| 2. MAIN UNIT AND ACCESSORIES .....             | 1 |
| 3. ELECTRICAL REQUIREMENT .....                | 2 |
| 4. SELECTING AN INSTALLATION LOCATION .....    | 2 |
| 4. 1. Dimensions .....                         | 2 |
| 4. 2. Installation restrictions .....          | 2 |
| 5. INSTALLING THE TOUCH PANEL CONTROLLER ..... | 2 |
| 5. 1. Installation preparations .....          | 3 |
| 5. 2. Terminal names .....                     | 3 |
| 5. 3. External input function .....            | 4 |
| 5. 4. Wiring method .....                      | 5 |
| 5. 5. Unit wiring .....                        | 6 |
| 5. 6. Installation method .....                | 7 |
| 6. TURNING ON THE POWER .....                  | 8 |

## 1. SAFETY PRECAUTIONS

- The "SAFETY PRECAUTIONS" indicated in the manual contain important information pertaining to your safety. Be sure to observe them.
- For details of the operation method, refer to the operating manual.
- Request the user to keep the manual on hand for future use, such as for relocating or repairing the unit.







|  |   |
|--|---|
|  <b>WARNING</b>  | This mark indicates procedures which, if improperly performed, might lead to the death or serious injury of the user. |
| Perform electrical work by an authorized service personnel in accordance with the installation manual and the electrical wiring regulations or implementation regulations of the country. Also do not install this unit by yourself. Improper electric work will cause electric shock or a fire.   |   |
| Perform installation work in accordance with the installation manual. Request an authorized service personnel to perform installation work. Do not install this unit by yourself. Improper installation will cause injury, electric shock, fire, etc.  |   |
| In the event of a malfunction (burning smell, etc.), immediately stop operation, turn off the electrical breaker, and consult authorized service personnel.  |   |
| Install a leakage circuit breaker to power supply cable in accordance with the related laws and regulations and electric company standards.  |   |
| Use a power source exclusively for this unit. Never share the power source with indoor unit or other electrical equipment. Doing so will cause fire and electric shock.  |   |
| Do not install the unit in the following areas: <ul style="list-style-type: none"> <li>• Do not install the unit near a source of heat, steam, or flammable gas.</li> <li>• Area filled with mineral oil or containing a large amount of splashed oil or steam, such as a kitchen. It will deteriorate plastic parts, causing the parts to fail or the unit to leak water.</li> <li>• Area that generates substances that adversely affect the equipment, such as sulfuric gas, chlorine gas, acid, or alkali. It will cause the copper pipes and brazed joints to corrode, which can cause refrigerant leakage.</li> <li>• Area containing equipment that generates electromagnetic interference. It will cause the control system to malfunction, and cause erroneous operation.</li> <li>• Area that can cause combustible gas to leak, contains suspended carbon fibers or flammable dust, or volatile inflammables such as paint thinner or gasoline. If gas leaks and settles around the unit, it can cause a fire.</li> </ul> |   |

|  |
|--|
| <ul style="list-style-type: none"> <li>• Do not use the unit for special purposes, such as storing food, raising animals, growing plants, or preserving precision devices or art objects. It can degrade the quality of the preserved or stored objects.</li> <li>• Install the unit in a well-ventilated place avoiding rains and direct sunlight.</li> </ul> |
| Do not operate this unit when your hands are wet. Touching the unit with wet hands will cause an electric shock.   |
| If children may approach the unit, take preventive measures so that they cannot reach the unit.  |
| This device is a CISPR22 Class A product. In a home environment, this unit may generate radio wave interference. In that case, the user must take appropriate countermeasures.   |

|   |   |
|---|---|
|  <b>CAUTION</b>  | This mark indicates procedures which, if improperly performed, might possibly result in personal harm to the user, or damage to property. |
| Pay abundant care when transporting this unit because it is a precision device. Improper transportation will cause trouble.   |   |
| Do not touch the switches with sharp objects. Doing so will cause injury, trouble, or electric shock.   |   |
| Do not expose this unit directly to water. Doing so will cause trouble, electric shock, or heating.   |   |
| Do not set vessels containing a liquid on this unit. Doing so will cause heating, fire, or electric shock.  |   |
| Dispose of the packing materials safely. Tear and dispose of the plastic packing bags so that children cannot play with them. There is the danger of suffocation if children play with the original plastic bags. |   |
| Do not insert articles into the slit parts of this unit. Doing so will cause trouble, heating, or electric shock.   |   |

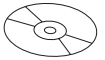
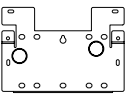
## 2. MAIN UNIT AND ACCESSORIES

The following parts are supplied. Use them as required.

| Name and Shape  | Q'ty | Application  |
|---|------|--|
| Touch panel controller<br> | 1    | Main unit  |
| Installation manual<br>    | 1    | This manual  |
| Operating manual<br>       | 1    | Instruction book for operation   |
| CD-ROM<br>                 | 1    | Include the operating manual for this controller   |
| Installation plate<br>     | 1    | For Touch Panel Controller installation (it is attached to the back of the Touch Panel Controller) |
| Screw (M4 x 20 mm)<br>     | 8    | Screw for touch panel controller installation  |
| Washer<br>                 | 8    | Washer for touch panel controller installation   |
| Cable tie<br>              | 4    | Prevents dropping off of the cable   |

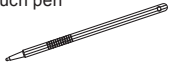
|  |   |  |
|--|---|--|
| Touch pen<br> | 1 | Pen for touch panel controller operation |
|--|---|--|

### 3. ELECTRICAL REQUIREMENT

When connecting the Touch Panel Controller, use the following wiring.

| Use                     | Size                             | Wire type   |
|-------------------------|----------------------------------|---|
| Power supply cable      | Max.1.25 mm <sup>2</sup> (16AWG) | Type 60245 IEC 57 or equivalent   |
|                         | Min.0.5 mm <sup>2</sup> (20AWG)  |   |
| Transmission cable (*1) | 0.33mm <sup>2</sup> (22AWG)      | 22AWG LEVEL 4 (NEMA) non-polar 2 core, twisted pair solid core diameter 0.65mm (0.026 in) |
| External input cable    | 0.33mm <sup>2</sup> (22AWG)      | 2 core, twisted pair (Max. cable length : 25m (82ft))                                     |

| Use                  | Remark   |
|----------------------|--|
| Power supply cable   | 1Φ 50/60Hz 100-240V<br>2 wire + earth (ground)<br>(Always earth (ground) the unit) |
| Transmission cable   | LONWORKS® compatible cable (*2)  |
| External input cable | Use cable in accordance with local rules for cable                                 |

- \*1. Twisted pair with shielded type. Use the shielded wire specified and always ground it both end.
- \*2. LONWORKS® is registered trademark of Echelon Corporation in the United States and other countries.

|               |     |
|---------------|-----|
| Fuse capacity | 5 A |
|---------------|-----|

### 4. SELECTING AN INSTALLATION LOCATION

#### 4.1. Dimensions

- Touch panel controller main unit and installation plate

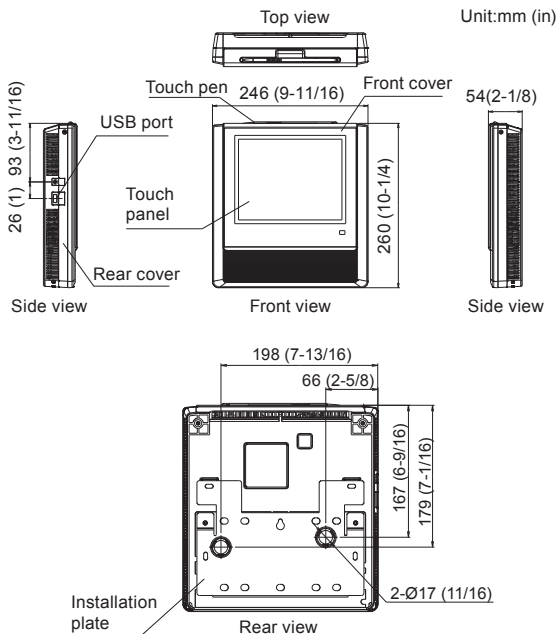

- \* For the screw position dimensions of the installation plate, see page 4.

### 4.2. Installation restrictions

- Surrounding space  
Provide the following space when installing touch panel controllers in a row and also provide the following space from the projecting parts of the surroundings.

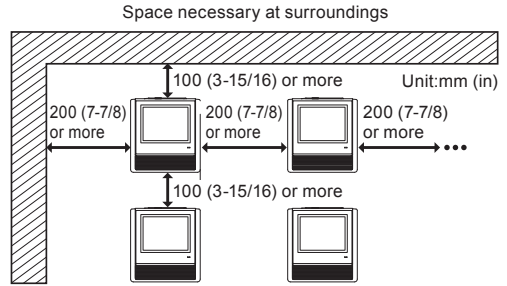

- \* Minimize the horizontal and vertical tilts of the switch box installed at the installation site in advance.
- Installation layout  
When installing the touch panel controller, installation layouts such as these are not allowed.



### 5. INSTALLING THE TOUCH PANEL CONTROLLER

#### ⚠ WARNING

Always use the accessories and specified installation work parts. Check the state of the installation parts. Not using the specified parts will cause fall, water leakage, electric shock, fire, etc.

Install at a place that can withstand the weight of the unit and install positively so that the unit will not topple or fall.

When installing this unit, make sure that there are no children nearby. Otherwise, injury or electric shock could result.

After this unit is installed, perform a test run to verify that the device operates normally. Then describe the operation method of this unit to the customer.

Install a circuit breaker. Not installing a circuit breaker will cause electric shock or fire.

#### ⚠ CAUTION

Before opening the case of this unit, remove all the static electricity accumulated on the human body. It will cause an accident.

When the front cover fixing screws are removed, be careful that the front cover does not fall off. It will cause an injury.

The circuit boards of this unit are at both the front cover and rear cover. When a cover is opened, the circuit boards may be damaged by the screwdriver. This will cause an accident.

The front cover and rear cover are connected by wiring. When disassembling, be sure that the wiring is not stretched.

Do not touch this unit's circuit board and circuit board parts directly with your hands. Doing so may cause electric shock or injury.

Tightening the mounting screws too tight will damage the case of this unit.

When inserting the hooks, do not push them in unreasonably. Doing so may damage or deform the claws.

Do not operate the surface of the touch panel with other than the accessory touch pen or your finger. It will scratch the surface and cause trouble.

## 5.1. Installation preparations

- Make ready the touch panel controller.

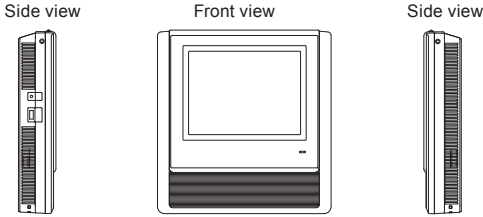

- (1) Remove the ① screw at 2 places at the top of both sides of the touch panel controller. (Fig. 1)
- (2) Separate the front cover part and the rear cover part.
- (3) Hook your finger at the notched part indicated by arrow ② and the rear cover and open in the direction of arrow ③. (Fig. 1)
- (4) Connect the front cover and rear cover and grasp and pull out the connector of the ④ connection cable. (Fig. 1)

Fig. 1

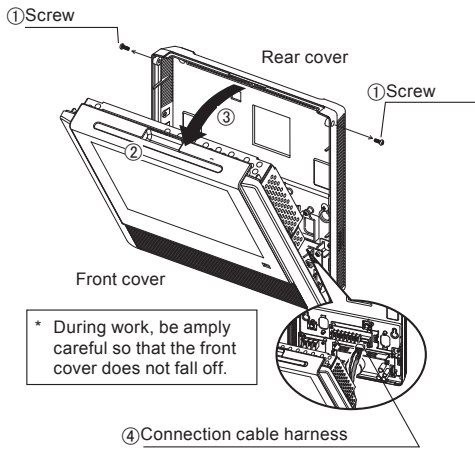

- (5) Remove the installation plate ⑤ fixing screws at 2 places from the inside of the rear cover. (Fig. 2)

Fig. 2

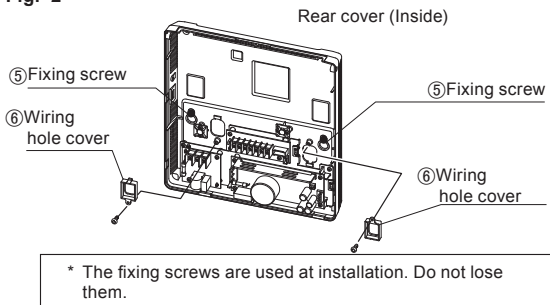

- (6) Installation plate dimensional drawing  
Separate the installation plate from the rear cover. (Fig. 3)  
Remove the screw at 2 places of the ⑥ wiring hole and remove the wiring hole cover. (Fig. 2)

Fig. 3

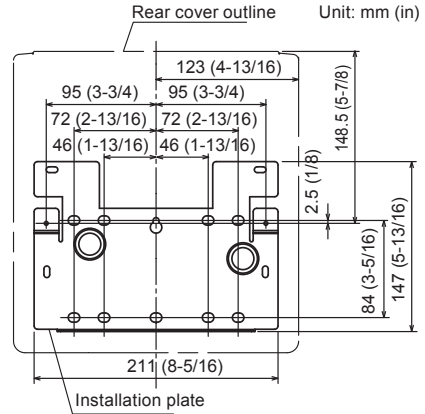
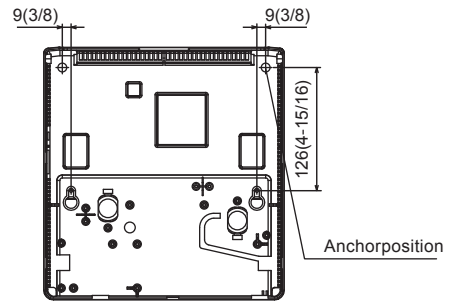

Fig. 4



- \* Refer to the dimensional drawing and verify the consistency of the hole positions of the installation screws of the switch box to be installed in advance. (Fig. 4)

## 5.2. Terminal names

- Terminal names: Names of connection terminals inside the rear cover

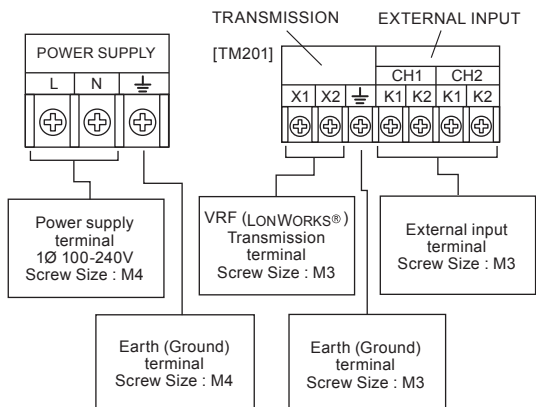
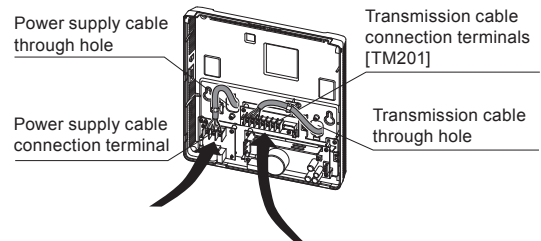

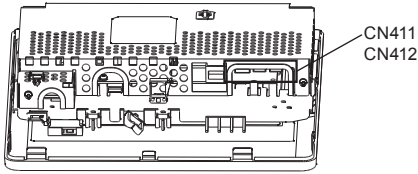

### 5.3. External input function

#### (1) External input terminals

Function which uses external input terminals to perform the "Emergency stop" or "Batch start/batch stop" operation from the outside.

#### (2) External input contact

CH1 and CH2 of TM201 of the rear cover are switched to "dry contact terminal" and "apply voltage terminal" by connecting CN201 on the front cover PCB to CN411 or CN412.

| TM201- CH1, CH2        | Connect with the CN201 |
|------------------------|------------------------|
| Dry contact terminal   | CN411 *                |
| Apply voltage terminal | CN412                  |

\* :Factory setting

#### • Dry contact terminal

When a power supply is unnecessary at the input device you want to connect, connect CN201 and CN411.

Connection example 1:  
When the switch is connected

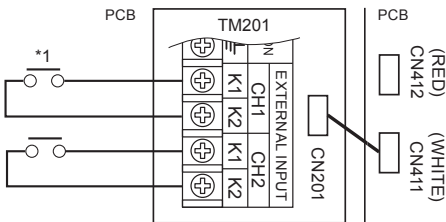

\*3. Short circuit detection resistance (R ON) :  $\leq 500 (\Omega)$ .  
Open circuit detection resistance (R OFF) :  $\geq 100 (k\Omega)$ .

\* A twisted pair cable  $0.33mm^2$  (22AWG) should be used. Maximum length of cable is 25m (82 ft).

Connection example 2:  
When the electricity meter is connected

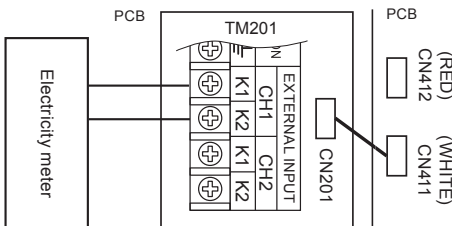

\* Connect the electricity meter to CH1. In this case, the use of CH2 is prohibited.

#### • Apply voltage terminal

When a power supply must be provided at the input device, connect CN201 and CN412.

Connection example 1:  
When the switch is connected

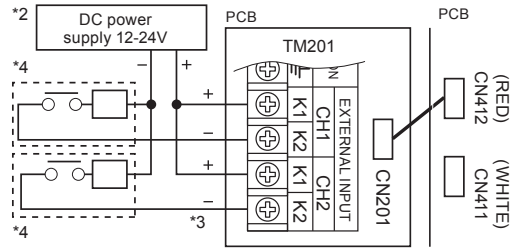

Connection example 2:  
When the electricity meter is connected

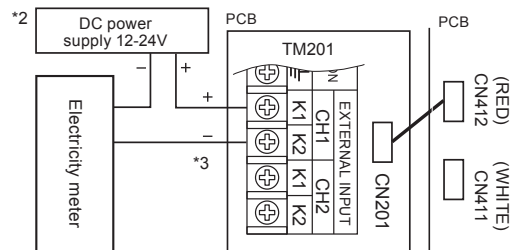

\*4. Make the power supply DC12 to 24V. Select a power supply capacity with an ample surplus for the connected load.

\*5. Do not impress a voltage exceeding 24V across K1-K2.

\*6. The allowable current is DC10mA or less. (Recommended DC5mA)

Provide a load resistance such that the current becomes DC10mA or less.

Select very low current use contacts (usable at DC12V, DC1mA or less).

A twisted pair cable  $0.33mm^2$  (22AWG) should be used. Maximum length of cable is 25m (82 ft).

#### (3) Selecting the function

The function of the external input terminals is disabled at the factory.

Select the function to be used (following table) by installer setting of application.

\* Turn on the power and select by installer setting after starting the application.

|                   |       |
|-------------------|-------|
| Emergency stop    | Edge  |
| Batch start/stop  | Pulse |
| Electricity meter |       |

#### (4) Input signal type

|       |                                    |     |        |  |
|-------|------------------------------------|-----|--------|--|
| Edge  | Emergency stop or batch start      | CH1 | H<br>L |  |
|       | Emergency stop reset or batch stop | CH1 | H<br>L |  |
| Pulse | Emergency stop or batch start      | CH1 | H<br>L |  |
|       | Emergency stop reset or batch stop | CH2 | H<br>L |  |
|       | Electricity meter signal           | CH1 | H<br>L |  |

H: Energized state L: Shutoff state

When Edge was selected, only CH1 can be used. CH2 cannot be used.

## 5. 4. Wiring method

### ⚠ WARNING

Before starting installation work, turn off the power of this unit and the connection destination. Do not turn on the power again until installation is completed. Otherwise, it will cause electric shock or fire.

Use the accessories or specified power supply cable and connection cables. Do not modify power supply cable and connection cables other than those specified, do not use extension cables, and do not use independent branch wiring. The allowable current will be exceeded and cause electric shock or fire.

Install the connection cables securely to the terminal block. Confirm that external force is not applied to the cable. Use connection cables made of the specified cable. If intermediate connection or insertion fixing are imperfect, it will cause trouble, electric shock, fire, etc.

When connecting the power supply cable and transmission cable, layout the wiring so that the cover of this unit is securely fixed. If the cover is imperfectly fixed, it may cause fire or overheating of the terminals.

Perform earth (ground) work positively. Do not connect the earth (ground) cable to a telephone cable, water pipe, or conductor rod. It will cause trouble or fire.

Always fasten the outside covering of the cable with cable tie. If the insulator is chafed by friction, electric leakage may occur.

Perform all wiring works so that the user does not touch the wiring. Otherwise, injury or electric shock could result.

If any cable is damaged, do not repair or modify it yourself. Improper work will cause electric shock or fire.

### ⚠ CAUTION

Do not bind up the power supply cable together with the transmission cable or remote controller cable. It will cause erroneous operation.

When performing wiring work, be careful not to damage the cable or injure yourself. Also, connect the connectors securely. Loose connectors will cause trouble, heating, fire, or electric shock.

Install the indoor and outdoor units, power supply cable, transmission cable and remote controller cable 1m (40in) away from television and radio to avoid distorted images and noise.

Perform wiring so that water does not enter this unit along the external wiring. Always install a trap to the wiring or take other countermeasures. Otherwise it will cause trouble, electric shock, or fire.

Confirm the name of each unit and name of each terminal block of the unit and connect the wiring in accordance with the directions given in the manual so that there is no incorrect wiring. Incorrect wiring will damage the electric parts and cause smoke and fire.

When installing the connection cables near a source of electromagnetic waves, use shielded cable. Otherwise, a breakdown or malfunction could result.

- When wiring between the outdoor unit, indoor unit, and touch panel controller, refer to the indoor unit and outdoor unit installation manuals.
- Always connect both ends of the earth (ground) connection of the transmission cable.
- Install the disconnect switch to the easily accessible location.
- Install the fuse (5A) to the L line of power supply cable.

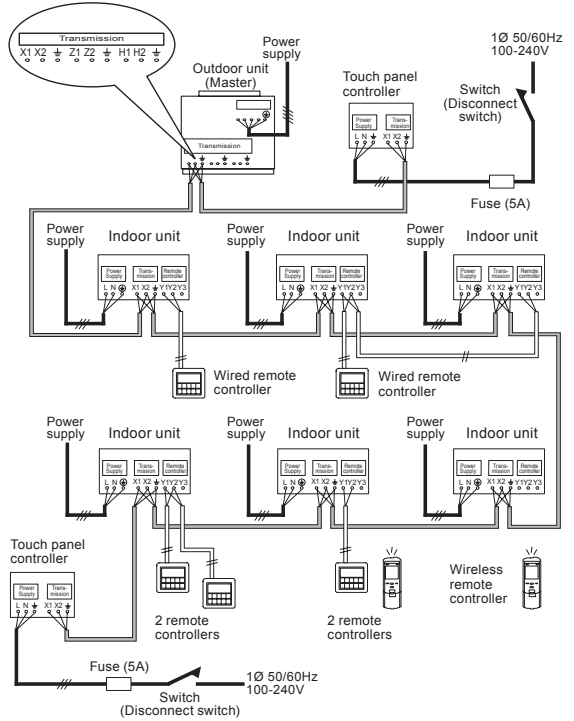

- Wire the transmission cable to any one of the following:

- ① Transmission terminal block inside the indoor unit (Fig. 1)
- ② External terminal block (Locally purchased) (Fig. 2)
- ③ Transmission terminal block inside the outdoor unit (Fig. 3)

Fig. 1

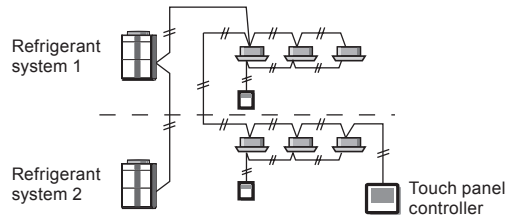

Fig. 2

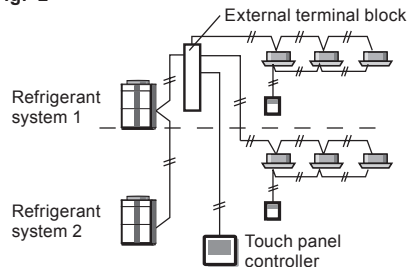
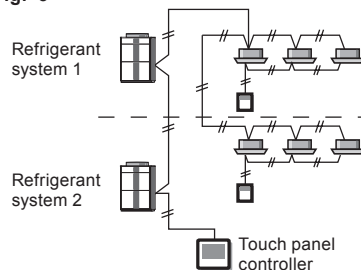

Fig. 3



## 5.5. Unit wiring

### 5.5.1 Power supply cable

Keep the ground cable longer than the other cables.

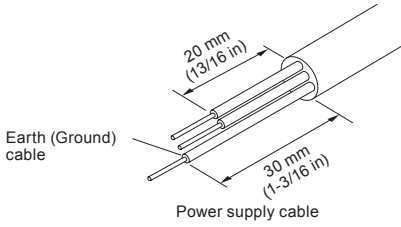

- (1) Use ring terminals with insulating sleeves as shown in the figure below to connect to the terminal block.
- (2) Securely clamp the ring terminals to the cables using an appropriate tool so that the cables do not come loose.
- (3) Use the specified cables, connect them securely, and fasten them so that there is no stress placed on the terminals.
- (4) Use an appropriate screwdriver to tighten the terminal screws. Do not use a screwdriver that is too small, otherwise, the screw heads may be damaged and prevent the screws from being properly tightened.
- (5) Do not tighten the terminal screws too much, otherwise, the screws may break.
- (6) See the table for the terminal screw tightening torques.
- (7) Do not fix 2 or more power supply cables with 1 screw.

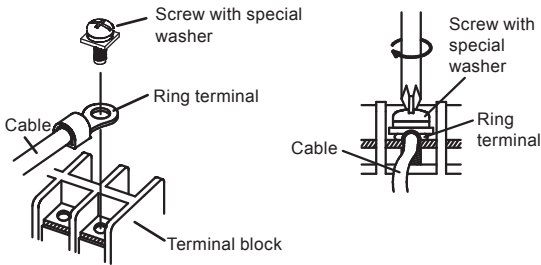

#### ⚠ WARNING

Use ring terminals and tighten the terminal screws to the specified torques, otherwise, abnormal overheating may be occurred and possibly cause heavy damage inside the unit.

#### Tightening torque

|  |  |
|--|--|
| M4 screw<br>(Power supply / L, N, GND) | 1.2 to 1.8 N·m<br>(12 to 18 kgf·cm)<br>(11 to 16 lbf·in) |
|--|--|

### 5.5.2 Transmission cable

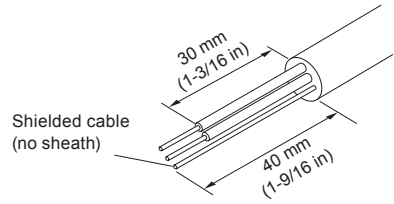

#### GOOD

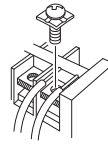

#### PROHIBITED

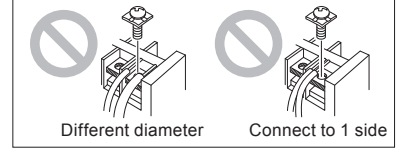

#### ⚠ WARNING

Tighten the terminal screws to the specified torques, otherwise, abnormal overheating may be occurred and possibly cause heavy damage inside the unit.

#### Tightening torque

|                                     |  |
|-------------------------------------|--|
| M3 screw<br>(Transmission / X1, X2) | 0.5 to 0.6 N·m<br>(5 to 6 kgf·cm)<br>(4.4 to 5.3 lbf·in) |
|-------------------------------------|--|

#### ⚠ CAUTION

To peel the sheath from the lead cable, use a dedicated tool that will not damage the conductor cable.

When installing a screw on the terminal block, do not cut the cable by overtightening the screw. On the other hand, an under tightened screw can cause faulty contact, which will lead to a communication failure.

## 5. 6. Installation method

- Install the switch box in advance to the wall to which the touch panel controller is to be installed.

- (1) Installation procedure
  - ① Verify that the power supply cable and transmission cable are wired to the switch box.
  - ② Peel the cable covering.
  - ③ Decide the path the power supply cable and transmission cable are to follow up to the terminals of the touch panel controller.
  - ④ After passing the power supply cable and transmission cable through the specified holes of the installation plate, fix the installation plate to the switch box using screws. Adjust the tilt of the installation plate by installing the accessory washers.
  - ⑤ In addition, pass the power supply cable and transmission cable through the wiring hole of the rear cover and fix the rear cover using the tapping screws (M4 x 8mm, 2 screws) supplied with the installation plate.
  - ⑥ Next, fix the rear cover to the wall using the 2 accessory screws (M4 x 20mm) and accessory washers.
  - ⑦ Fix the cables at 2 places by cable ties.
  - ⑧ Provide a surplus of 5mm or more from the end of the covering of the cable and fix the part which is fixed by the cable ties.
  - ⑨ Fix the power supply cable and transmission cable to their respective terminal so that there is no mistake.
  - ⑩ Fill the cable holes with putty in order to prevent small animals from entering.
  - ⑪ Insert the connector of the connection cable.
  - ⑫ Close the front cover and rear cover. Align the claw of the bottom of the front cover and fit the top to the rear cover.
  - ⑬ Tighten the 2 screws at the side of the main unit.
- When LAN cable is connected, wire as shown in the figure.

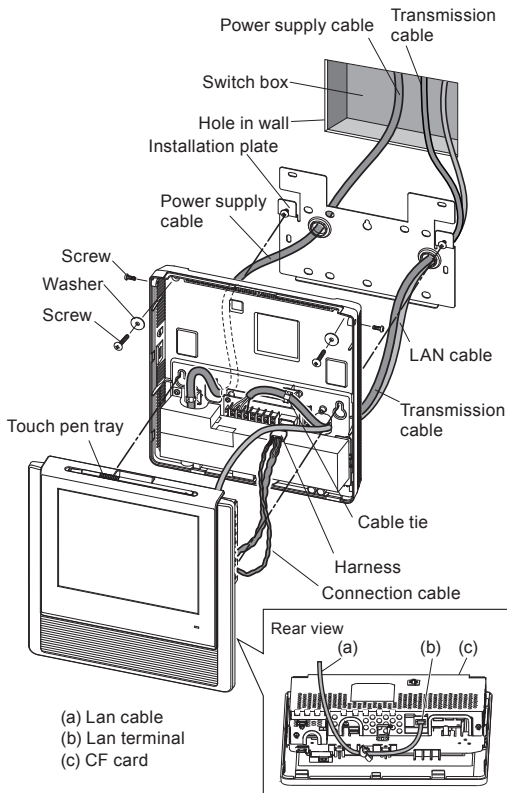

### • Detail description of power supply cable connection

- ① Remove the screw.
- ② Remove the power supply terminal cover.

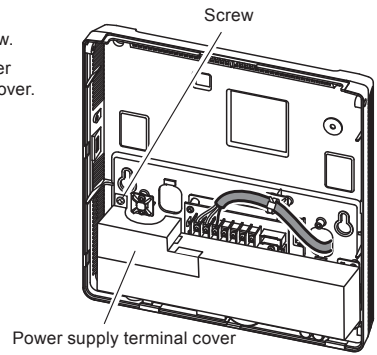

- ③ Connect the power supply cable to the power supply terminal.
- ④ Mount the power supply terminal cover. Then, take care that the power supply cable does not get caught in the edge of power supply terminal cover.
- ⑤ Tighten the screw.

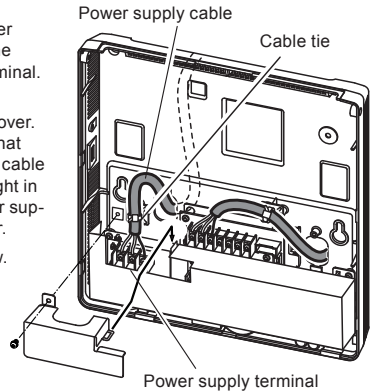

- (2) Installation of touch pen

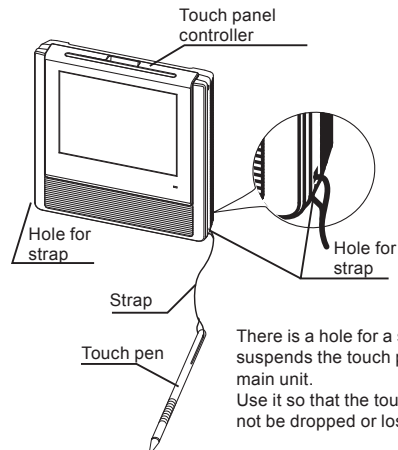

There is a hole for a strap which suspends the touch pen at the main unit. Use it so that the touch pen will not be dropped or lost.

\* There are holes for a strap at both sides of the main unit. Install at the easiest hole to use.



## 6. TURNING ON THE POWER

### CAUTION

Check that the power supply voltage is within the specified range. If a power supply voltage outside the specification is input, it will cause trouble.

Recheck the wiring. Incorrect wiring will cause trouble.

After installation work is completed, check the following contents:

- ① Is touch panel controller power supply cable and transmission cable wiring work complete?
- ② Does the power supply match the rating of the touch panel controller?
- ③ Turn on the touch panel controller main unit power. Since there is no power switch at the main unit, turn on the power by means of the power distribution panel.
- ④ If the following installer setting screen is displayed at the screen of the touch controller panel, installation work is complete.

For setting and operating of the touch panel controller, refer to the separate operating manual.

\* Since there is some kind of a problem when the installer setting screen does not appear, recheck the work contents. Then, check that CF card is inserted firmly.

