

## 3. Adaptor/Converter units

### RELATED LINKS



"Adapter/Converter/Maintenance tool" in Chapter 1. GENERAL INFORMATION

### 3-1. Network converter (UTY-VTGX)

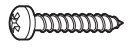

- With this Network converter, single split type and multi system air conditioners can be controlled by System controller, Touch panel controller, Central remote controller in VRF network system or by Wired remote controller connected to the Network converter.
- Start/Stop, operation mode, temperature setting, fan speed, etc. can be done with these controllers.
- One Network converter can be connected and controlled up to 16 indoor units.
- One Wired remote controller is possible for one Network converter by UTY-VTGX.
- Up to 100 Network converter can be connected in one VRF network system. (One Network converter is regarded as one refrigerant system. The total refrigerant system in one VRF network system must be within 100.)

#### ■ Accessory

Name and shape	Q'ty	Application
 Cable tie	7	For mounting the remote controller cable and transmission cable
 Screw (M4 × 16 mm)	4	For mounting the Network converter
 Installation manual	1	

# System diagram

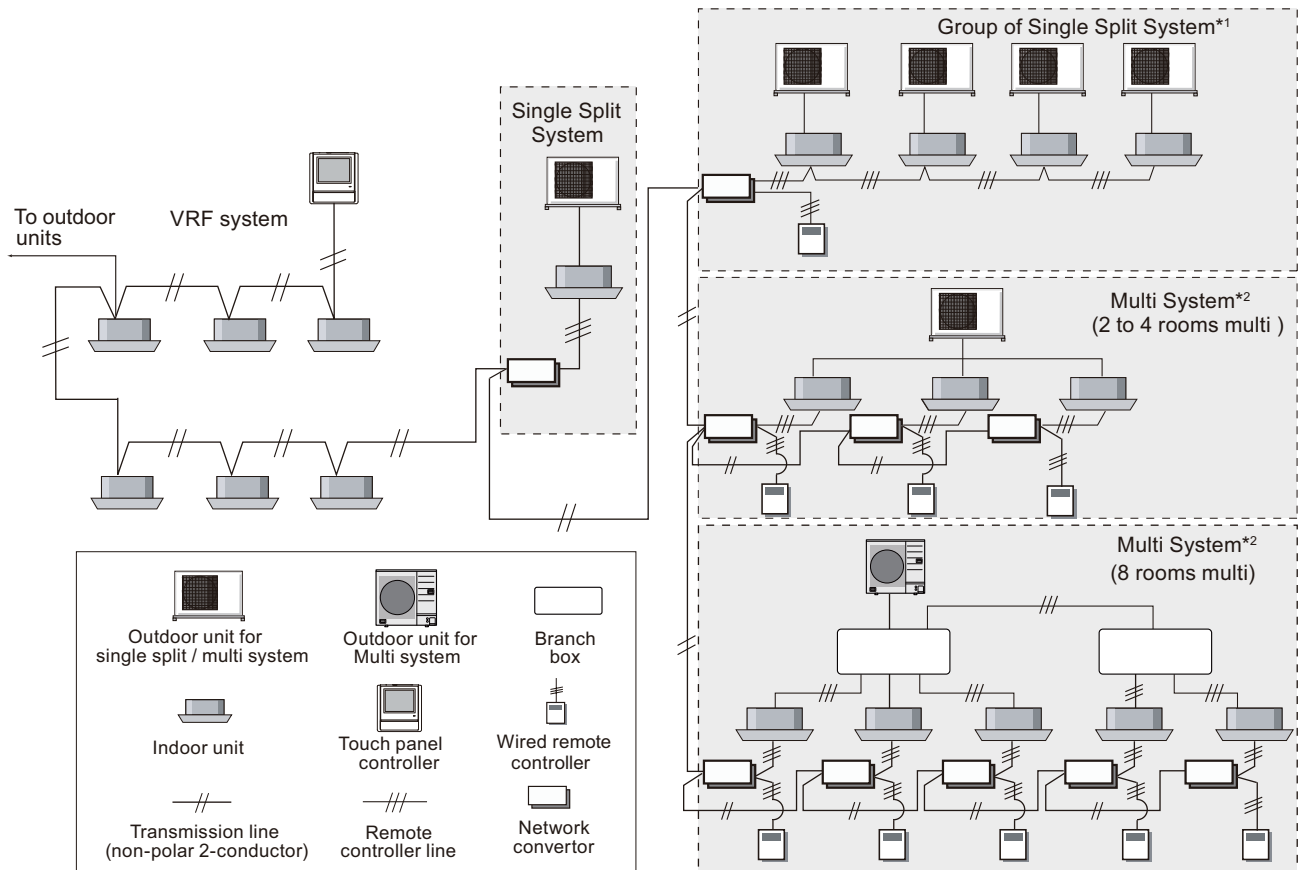

\*1: All indoor units connected to a Network converter are operated under same status.

\*2: Network converter is necessary for each indoor unit to control indoor unit individually.

CONTROL SYSTEM

CONTROL SYSTEM

## ■ Electrical wiring

- For non-polar 2 wire

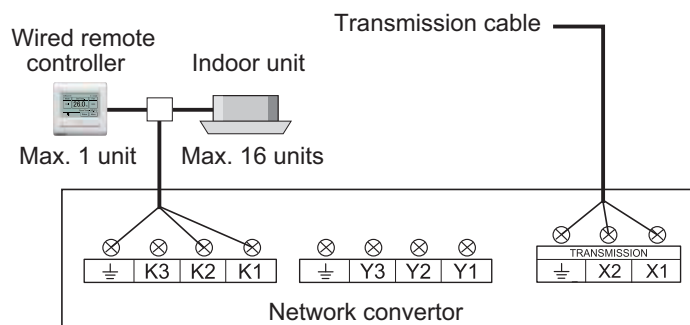

- For polar 3 wire

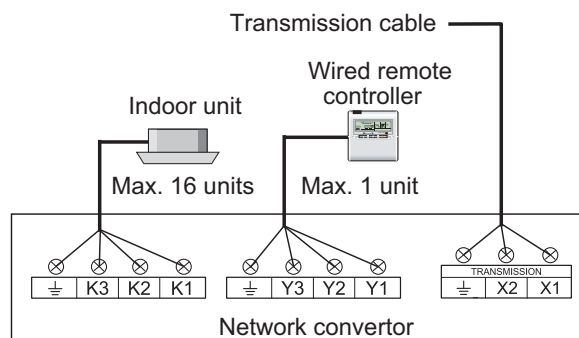

### NOTES:

- Do not bind the power cable and the remote controller cable to avoid erroneous operation.
- Use shielded cable for transmission cable in accordance with the regional cable standard.
- Use sheathed PVC cable or shielded cable for remote controller cable in accordance with the regional cable standard.
- Use ground wire to ground the Network converter.

## ■ Limited wiring length

- **For non polar 2-wire**

Up to 4 remote controllers can be used to operate the indoor units.

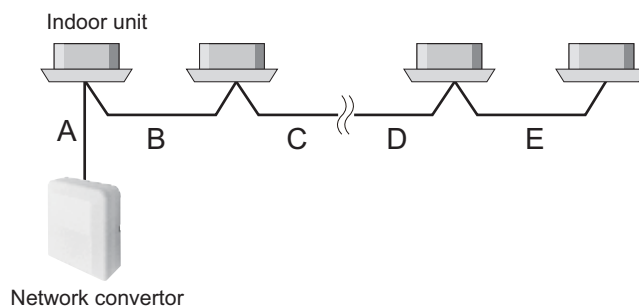

A, B, C, D, E: Remote controller cable (For details of controller cable specifications, refer to "Controller cable" in Chapter 6. SYSTEM DESIGN.)

$A \leq 2 \text{ m}$ ,  $A + B + C + D + E \leq 500 \text{ m}$

- **For polar 3-wire**

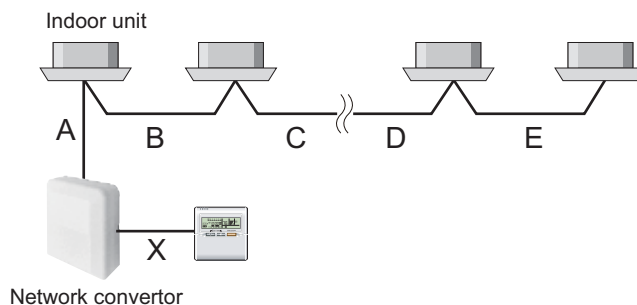

A, B, C, D, E, X: Remote controller cable (For details of controller cable specifications, refer to "Controller cable" in Chapter 6. SYSTEM DESIGN.)

$A \leq 2 \text{ m}$ ,  $A + B + C + D + E \leq 100 \text{ m}$  and  $X \leq 100 \text{ m}$

## ■ Connectable remote controllers

3 types of wired remote controller shown in the table below can be connected to this product.

This product is connectable to indoor units that following wired remote controllers can be connected.

Model name	RC number	Type
UTY-RNR* UTY-R*R*Z*	AR-WEC** AR-WED** AR-WEE** AR-WEF** AR-WFA** AR-WFB** AR-WFC** AR-WFD** AR-WGA** AR-WGB**	Non polar 2-wire
UTB-YUD	AR-6TC**	Polar 3-wire
UTY-R*N*M UTY-R*K*	AR-WAE** AR-WAF** AR-WAG** AR-WBE** AR-WBF** AR-WBG** AR-WDC** AR-WDD**	

\*: Numerical character or alphabetical character

## ■ Functions

Operation	Non polar 2-wire	Polar 3-wire
Operation of louver from VRF	○	×
Operation of louver from wired remote controller	○	○
Restriction of wireless remote controller from central control	○	×
Restriction of wired remote controller from central control	○	○
Anti-freeze	×	×
Setting high and low temperature limit	○	×
Indoor unit rotation	×	×
Turning off indoor unit external thermostat	×	×
Outdoor unit forced stop	×	×
Outdoor unit capacity save	×	×
Outdoor unit low noise	×	×
Electricity distribution	×	×
Display model name	×	×
System time	○	×
Remote setting	×	×
Local setting by the wired remote controller	○	×

## ■ Dimensions

Unit: mm

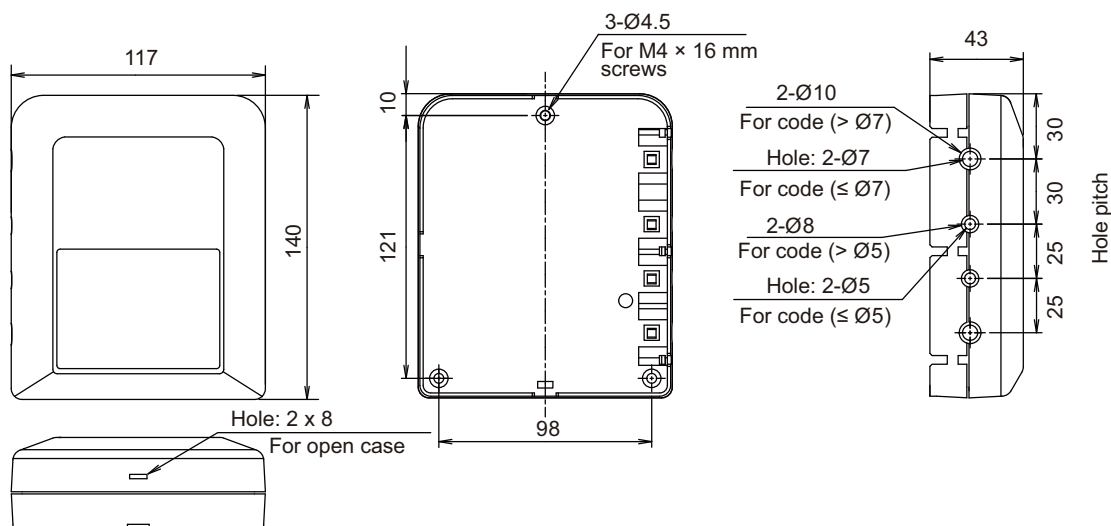

## ■ Specifications

Input power		W	2
Temperature	Operating	$^{\circ}\text{C}$	0 to 46
	Packaged	$^{\circ}\text{C}$	-10 to 60
Humidity	Packaged	%	0 to 95 (RH) No condensation
Dimensions (H $\times$ W $\times$ D)		mm	140 $\times$ 117 $\times$ 43
Weight		g	250

## ● Wiring specifications

Use	Cable size	Wire type	Remarks
Transmission cable	0.33 mm <sup>2</sup> (22 AWG)	LEVEL 4 (NEMA) Non-polar 2 core, twisted pair solid core shielded	LonWorks compatible cable
Remote controller cable (2-wire type)	0.33 to 1.25 mm <sup>2</sup> (22 to 16 AWG)	Non-polar 2 core	Use sheathed PVC cable or shielded cable in accordance with the regional cable standard.
Remote controller cable (3-wire type)	0.33 mm <sup>2</sup> (22 AWG)	Polar 3 core	