

2-4. UTZ-BD080C

Unit: mm

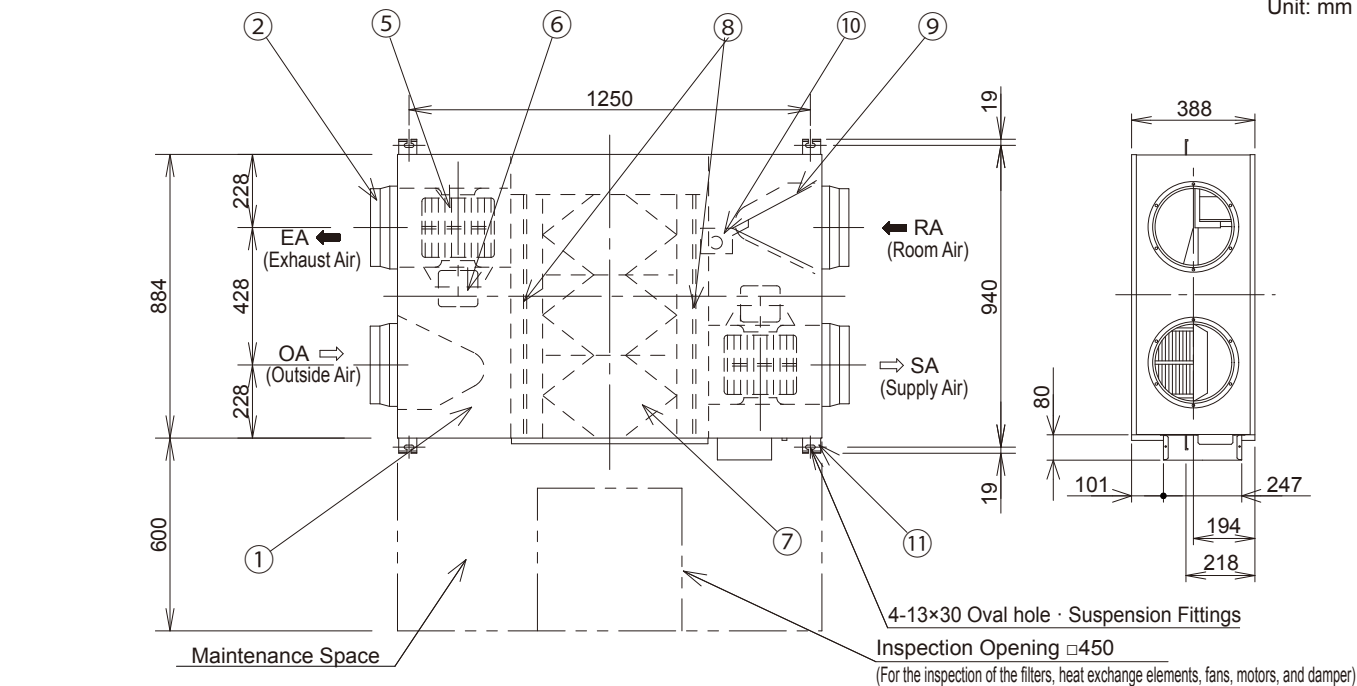

An inspection opening is necessary to clean the heat exchange element and filter once or twice a year.

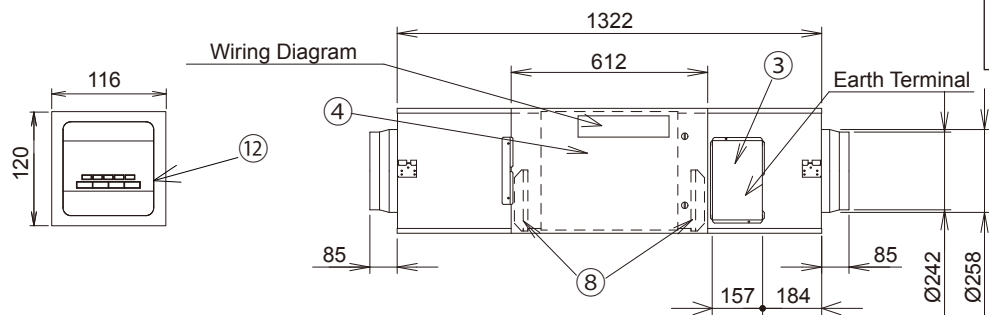

NO.	Parts Name	Qty.	Material	Remarks
1	Frame	1	Galvanized sheets	
2	Adapter	4	ABS	
3	Electrical Equipment Box	1		
4	Inspection Cover	1	Galvanized sheets	
5	Fan	2	ABS	
6	Motor	2		
7	Heat Exchange Element	3	Special paper + Resin	
8	Filter	2	Nylon-Polyester Fiber	Collection Efficiency AFI 82%
9	Damper	1		
10	Damper Motor	1		
11	Ceiling Suspension Fixture	4	Galvanized sheets	
12	Energy Recovery Ventilator Remocon	1		

BE CAREFUL OF DEWING AND FROSTING

As shown in the Figure, suppose a high temp absorbing air condition A and a low temp absorbing air condition B are plotted on the air line figure, then a high temp air A is heat-exchanged by the unit and goes out of the saturation curve as shown by Point C. In this case, the unit will be dewed or frosted. To avoid this, you are required to heat a low temp air B up to B' so as to get C' below the saturation curve, before using the unit.

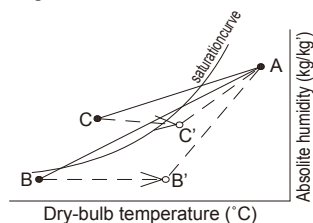

REFERENCE SKETCH

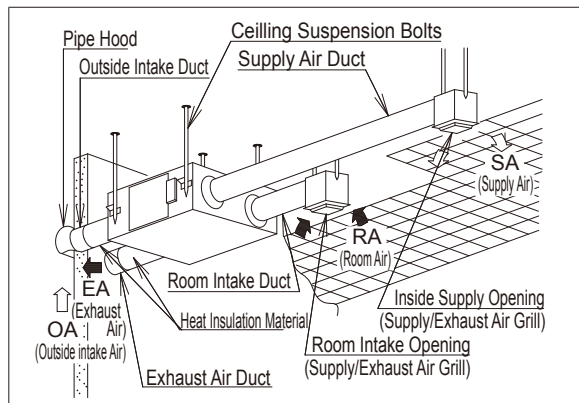

The two outside ducts (the Outside Intake Duct and the Exhaust Duct) must be insulated to prevent condensation. (Material: Glass wool, Thickness: 25)

- * Duct size (Nominal Diameter): $\phi 250$
- ** The above dimensions do not include the thickness of the insulation material on the unit body.

■ SPECIFICATIONS

Model No.	Power Source	Notch	Frequency (Hz)	Heat Exchange Ventilation							Normal Ventilation					Product Weight (kg)	
				Input (W)	Current (A)	Air Volume (m ³ /h)	External Static Pressure (Pa)	Temperature Exchange Efficiency (%)	Enthalpy Exchange Efficiency (%)		Noise (dB)	Input (W)	Current (A)	Air Volume (m ³ /h)	External Static Pressure (Pa)		Noise (dB)
									Cooling	Heating							
UTZ-BD080C	220-240V a.c.	Extra High	50	387-418	1.76-1.74	800	140	75	65	71	37.0-37.5	387-418	1.76-1.74	800	140	37.0-37.5	71
		High	50	360-378	1.64-1.58	800	110	75	65	71	36.5-37.0	360-378	1.64-1.58	800	110	36.5-37.0	
		Low	50	293-295	1.33-1.23	630	55	76	68	74	33.5-34.5	293-295	1.33-1.23	630	55	33.5-34.5	

* This noise of the product is the value which was measured at the acoustic room. Actually, in the established condition, that undergo influence by the echoing of the room and so that become bigger than the display numerical value.

■ PERFORMANCE

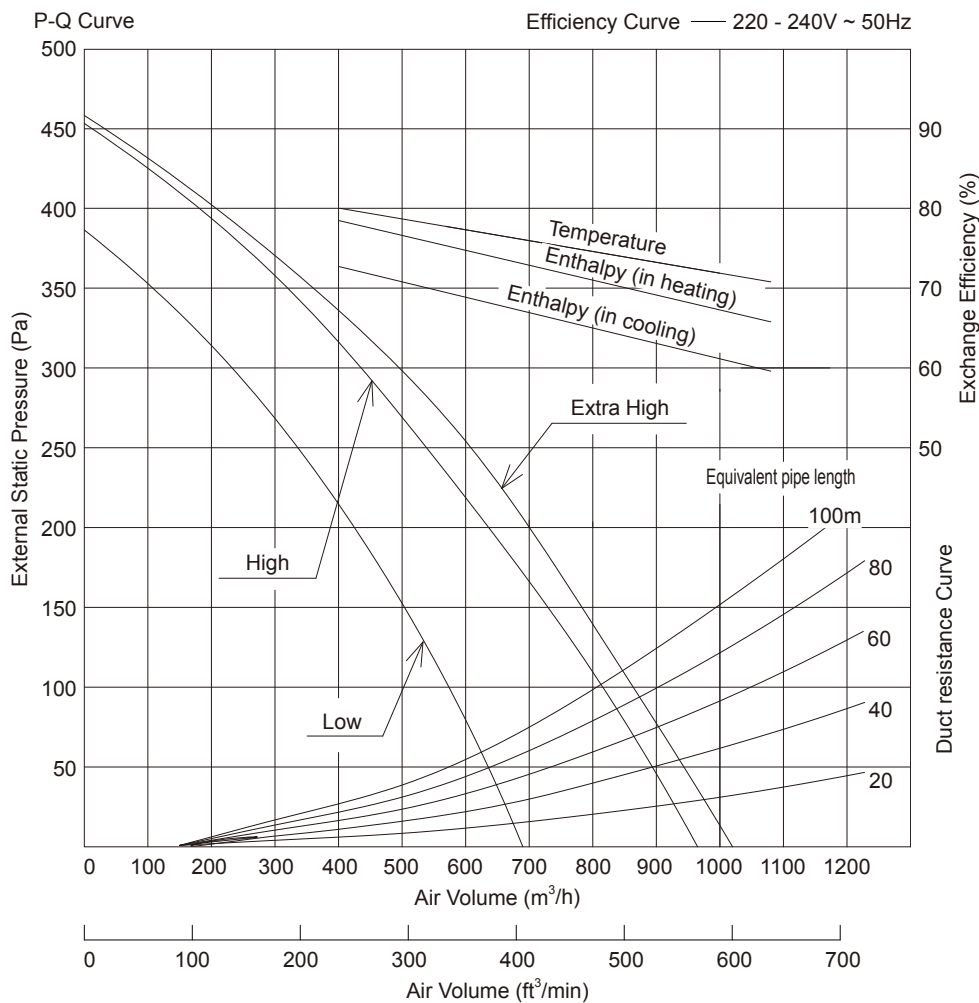

* When friction coefficient of pipe (duct) : $\lambda=0.02$

Use conditions	
Outdoor air conditions	Temperature range -10°C ~ 40°C Relative humidity 85% or less
Indoor air conditions	Temperature range -10°C ~ 40°C Relative humidity 85% or less
Installation requirements	Same as the indoor air conditions
* Indoor air here means air in air-conditioned living rooms. Its use in refrigerators or other places where temperature can fluctuate greatly is prohibited even if a temperature range is acceptable.	
Example	Indoor air conditions
	During cooling period Temperature 27°C Relative humidity 50%
	During heating period Temperature 20°C Relative humidity 40%

■ MOTOR SPECIFICATIONS

Type	4 Poles open type induction motor
Rating	Cont.
Insulation Class	class B
Temperature Rise	under 80 K
Surrounding Temperature	-10°C ~ 40°C
Insulation Resistance	over 1MΩ (by DC500V)
Withstand Voltage	AC 1,500V for 1min
Input (Reference)	193-209 W (220-240V)
Output (Reference)	180 W (220V)
Diameter	Ø123 mm
Weight	3.5 kg
Lot 11	Applicable (Over 125W)

- The Input, the current and the exchange efficiency are values at the time of the mentioned air volume.
- The noise level shall be measured 1.5m below the center of the unit.
- The temperature exchange efficiency averages that of when cooling and when heating.